

ROUND Plume

Components list

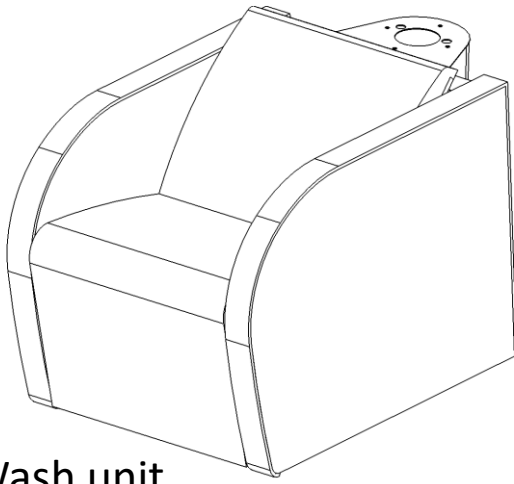

x1 Wash unit

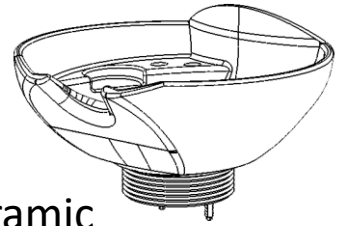

x1 Ceramic

Instructions

Fig.1

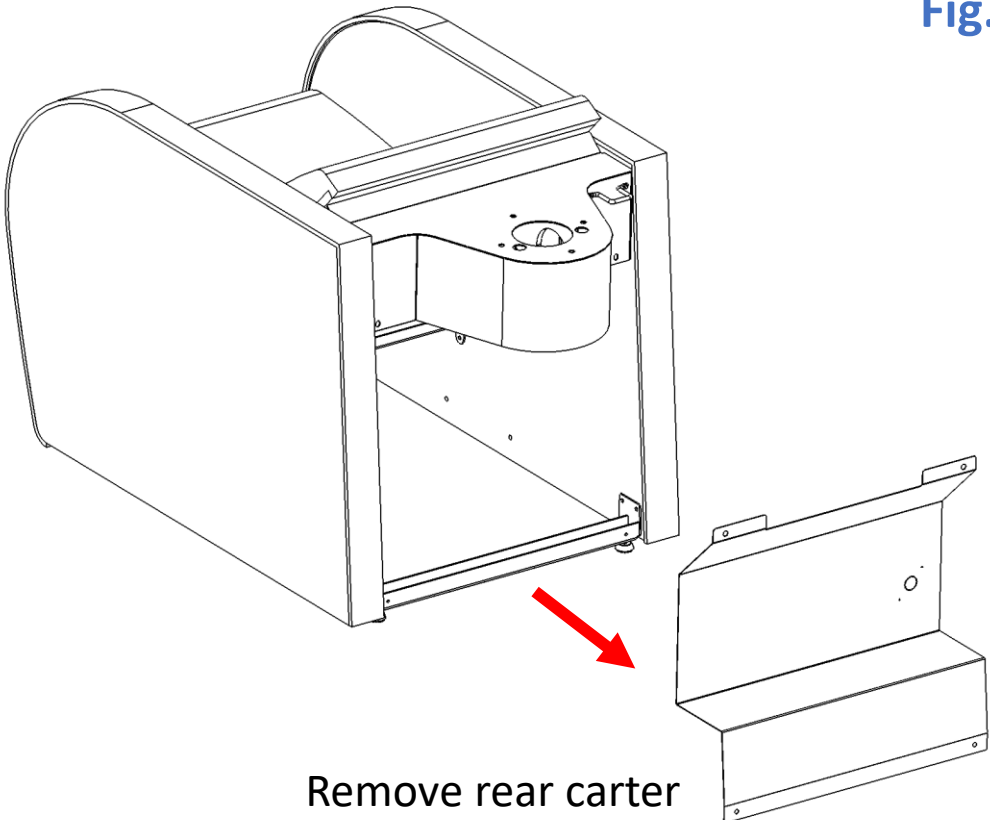

Remove rear carter

Fig.2

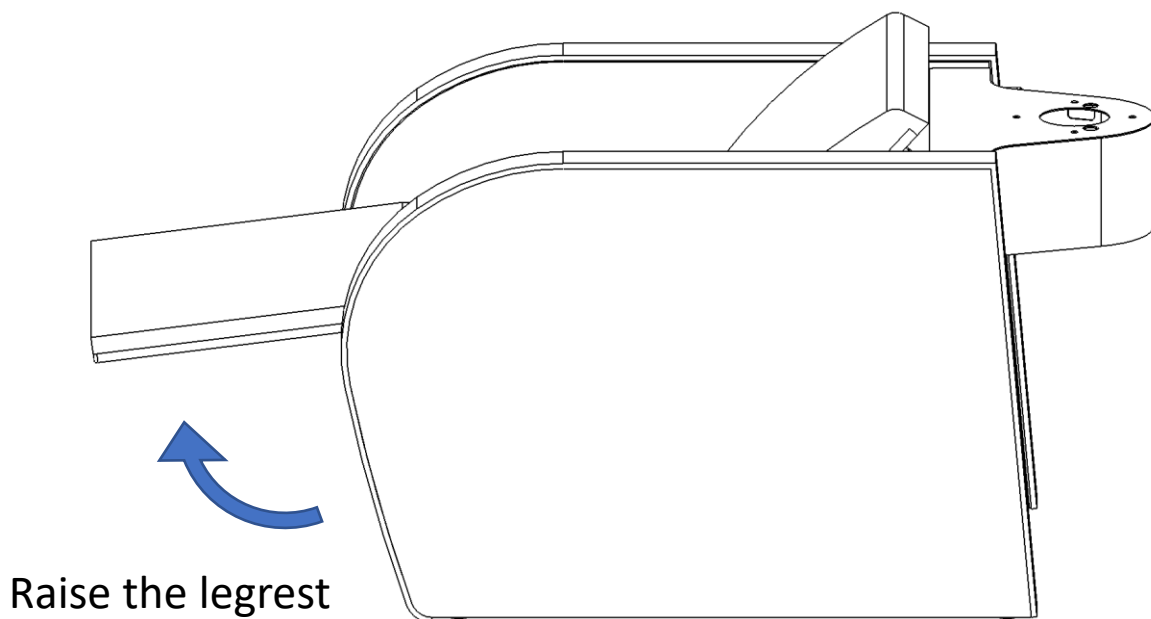

Fig.3

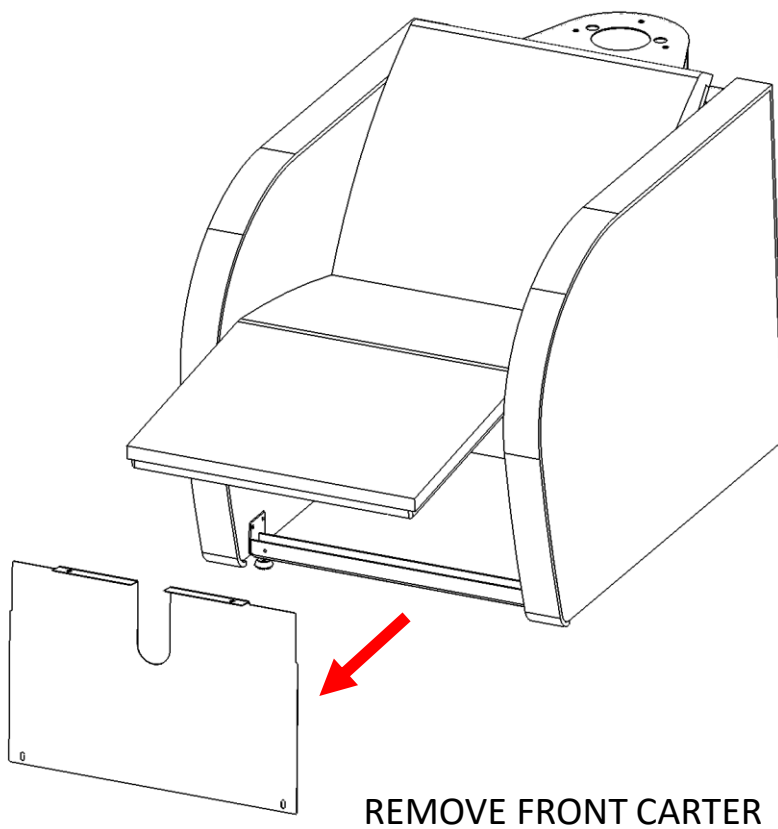
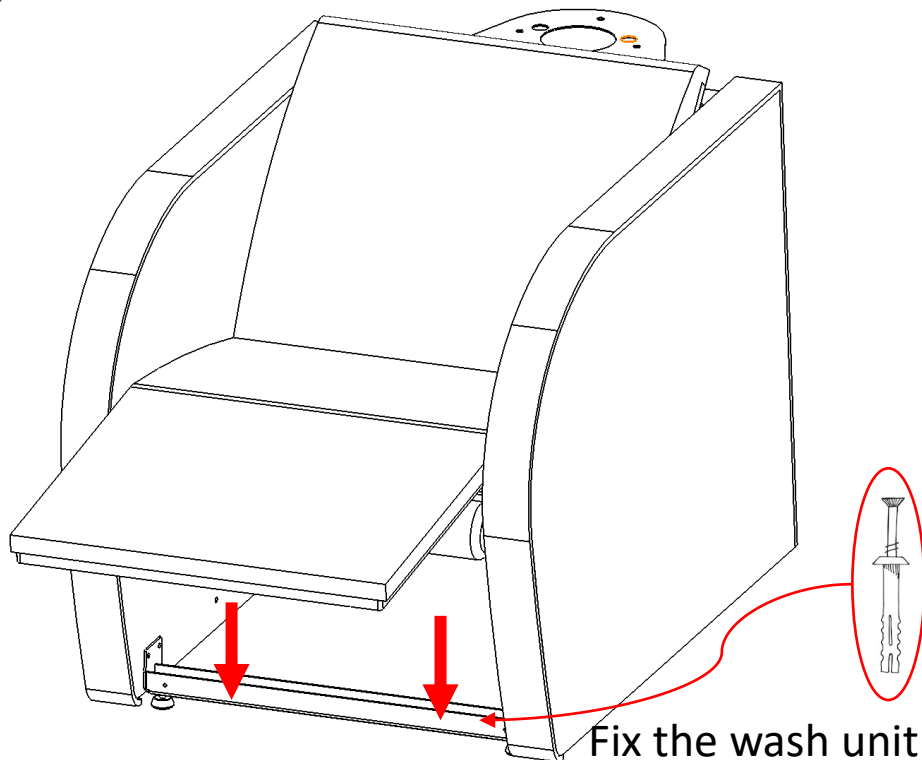
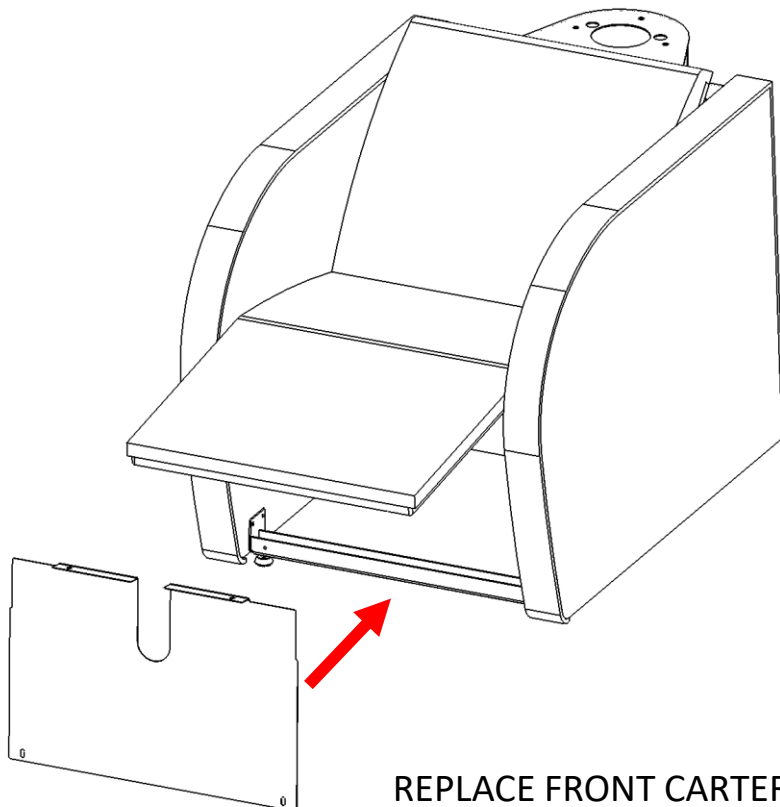

Fig.4



Fix the wash unit to the floor
-Observe connection/project sheet-

Fig.5



REPLACE FRONT CARTER

Fig.6

Insert the ceramic on
the support

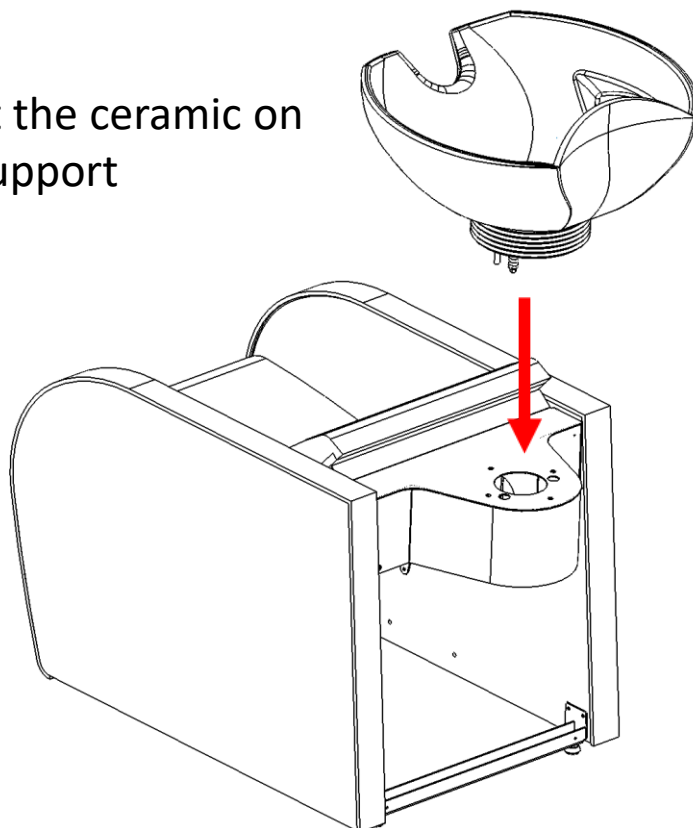

Fig.7

Screw n°4 nut M8
under the support

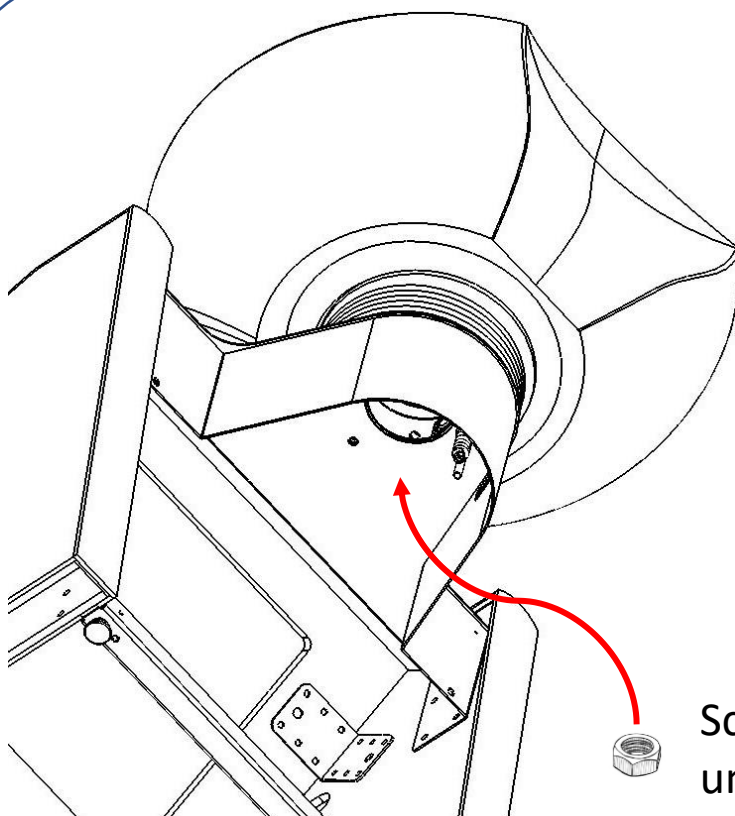

Fig.8

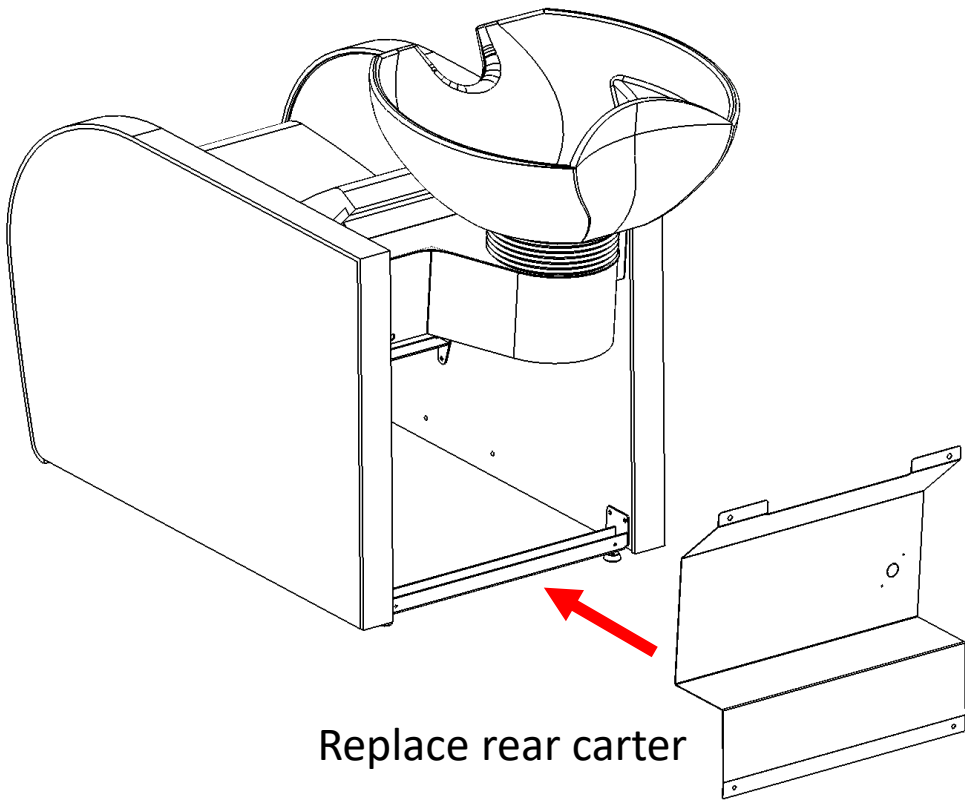
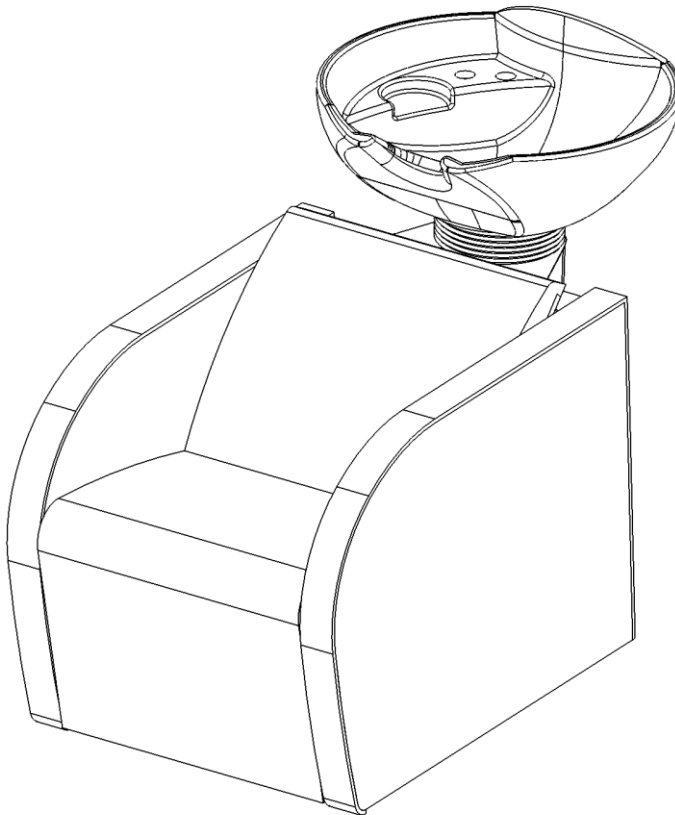

Fig.9



ROUND PLUME

POSIZIONE DA CONSIDERARE PER OTTENERE UNA DISTANZA = SPAZIO DI LAVORO PARI A 60 CM DAL RETROCODETTA AL MURO.

POSITION TO BE CONSIDERED TO OBTAIN A DISTANCE SAME AS THE WORKING SPACE EQUAL TO 60 CM FROM BACK BASIN TO WALL

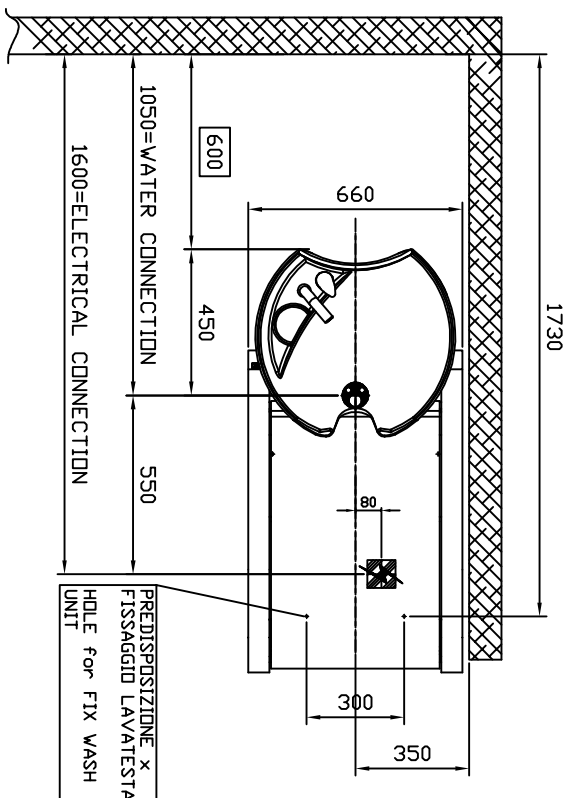
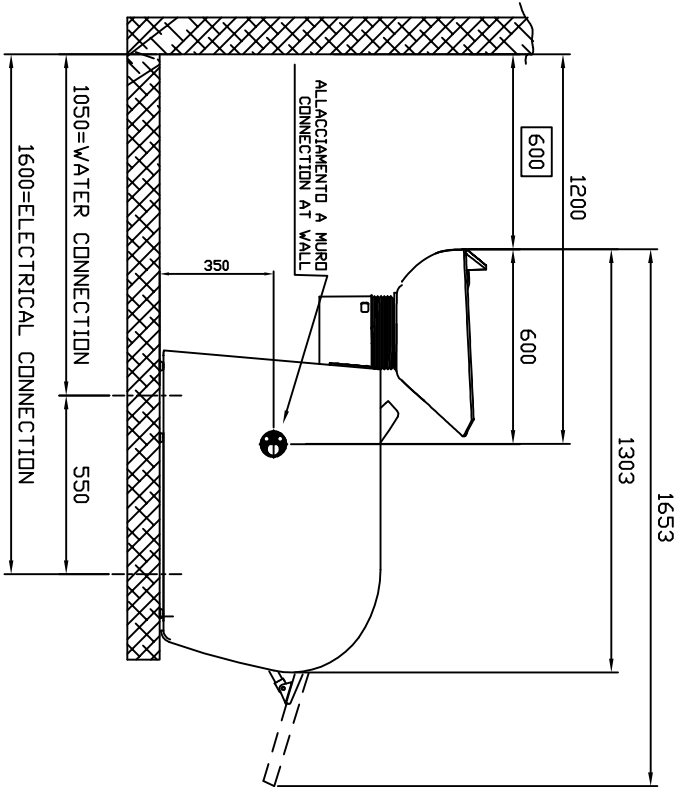
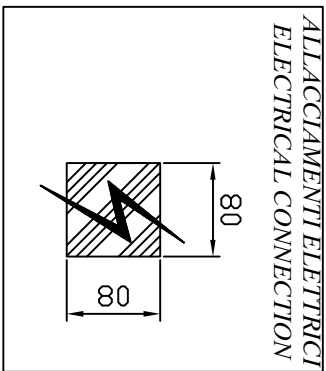
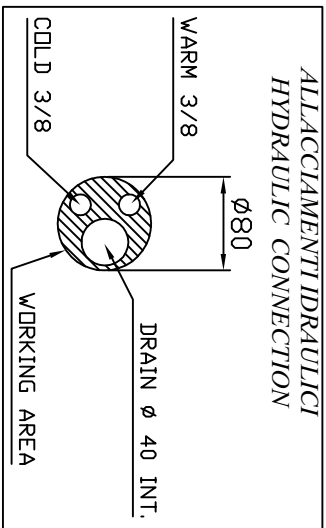
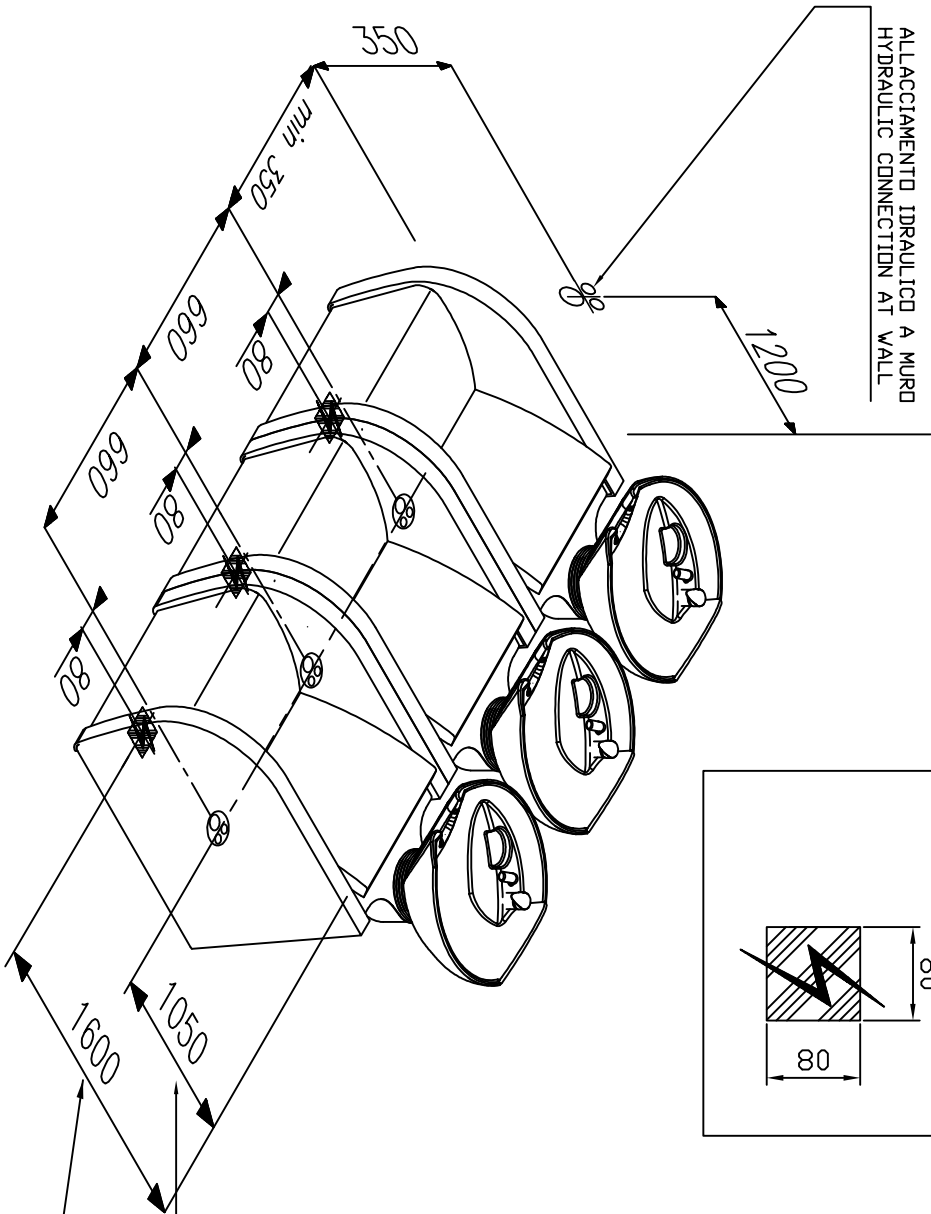

ALLACCIAMENTO IDRAULICO
HYDRAULIC CONNECTION

ALLACCIAMENTO ELETTRICO
ELECTRICAL CONNECTION

PREDISPOSIZIONE x
FISSAGGIO LAVATESTA
HOLE for FIX WASH
UNIT