

Innovation spirit!

# SIGMA EVOLUTION STRAW BLOWER

PTO version **NEW**

## ▶ Loading

The loading door opens with two rams. There are retaining arms to hold the square bales.



## How it works

Designed for tractors, the straw blower can spread round or square bales up to 15 meters away.

## ▶ Spreading

Thanks to the **walking triple floor** the bale is driven to the rotor which feeds the turbine. The turbine is directly driven by the tractor PTO. The speed of the floor can be adjusted from the cabin by the control box to ensure an even spreading.

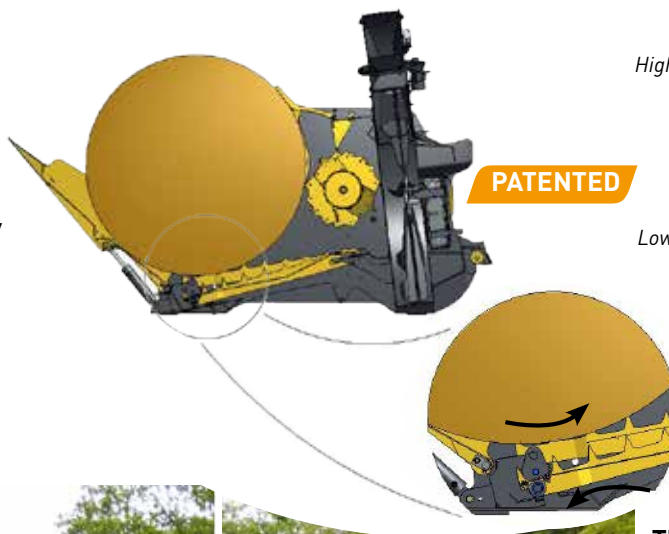

High position

Low position

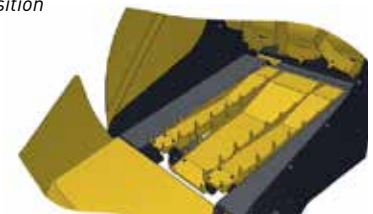
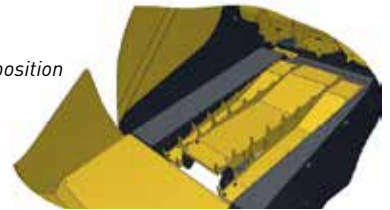

**The rotor:** driven by an integrated hydraulic motor; its helicoid shape optimizes efforts and does not over consume hydraulic power.

**The turbine:** directly driven by the PTO. Turbine speed controlled with a double speed gearbox to adjust the spreading distance.

**Swivel chute:** 260° rotation thanks to a hydraulic motor; up and down orientation thanks to an electric ram for higher precision.

### STANDARD EQUIPMENTS

- Hydraulic door
- Retaining tines for square bales
- Swivel and angle chute (260°)
- Electric remote control box



Innovation spirit !

## SIGMA EVOLUTION STRAW BLOWER PTO version **NEW**

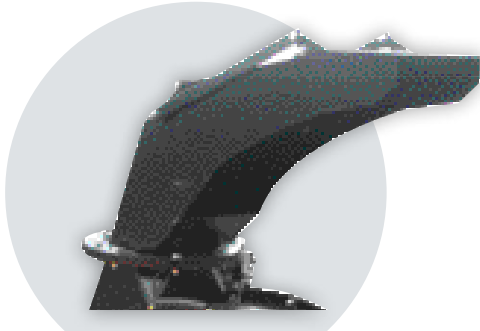

**260° swivel chute** controlled by a joystick for a higher precision.



**Spiral rotor** with integrated hydraulic motor.

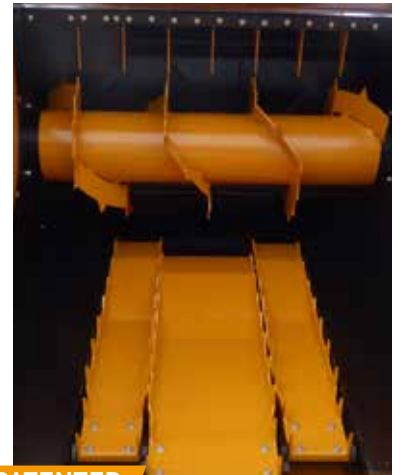

**PATENTED**

**Walking triple floor** driven by hydraulic motors. No gear and no chain: maintenance free.



Rear view with PTO



Electric remote control box

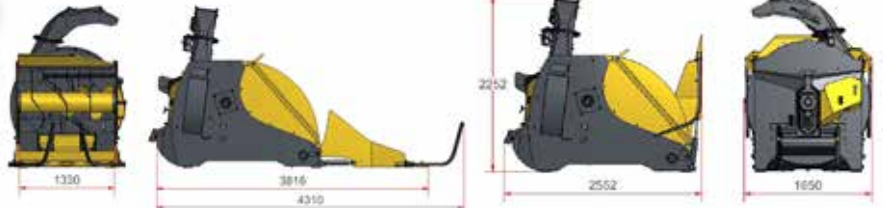

### EMILY advantages

- ⊕ **EXCLUSIVITY:** the walking triple floor (patented) is activated by hydraulic motors.
- ⊕ **CONVENIENCE:** optimized weight, optimized visibility and offset.
- ⊕ **RELIABILITY:** walking floor hydraulically driven: maintenance free. Bolted blades on the turbine.
- ⊕ **CAPACITY:** 260° swivel chute controlled by a joystick. Spreading up to 15 m away.
- ⊕ **PRECISION:** swivel chute inclination thanks to an electric ram.
- ⊕ **ERGONOMICS:** ergonomic and intuitive remote control box in the cab.
- ⊕ **STURDINESS:** reinforced door with flared end.

Sigma Evolution  
PTO version

Weight 1 390 kg

70 HP minimum

EMILY - ZA Les Landes 29800 Tréflévénez  
France

T. +33 (0)2 98 21 86 12

F. +33 (0)2 98 21 86 14

M. [export@emily.fr](mailto:export@emily.fr)

[www.emily.fr/en](http://www.emily.fr/en)

