

Installation manual

ferroamp

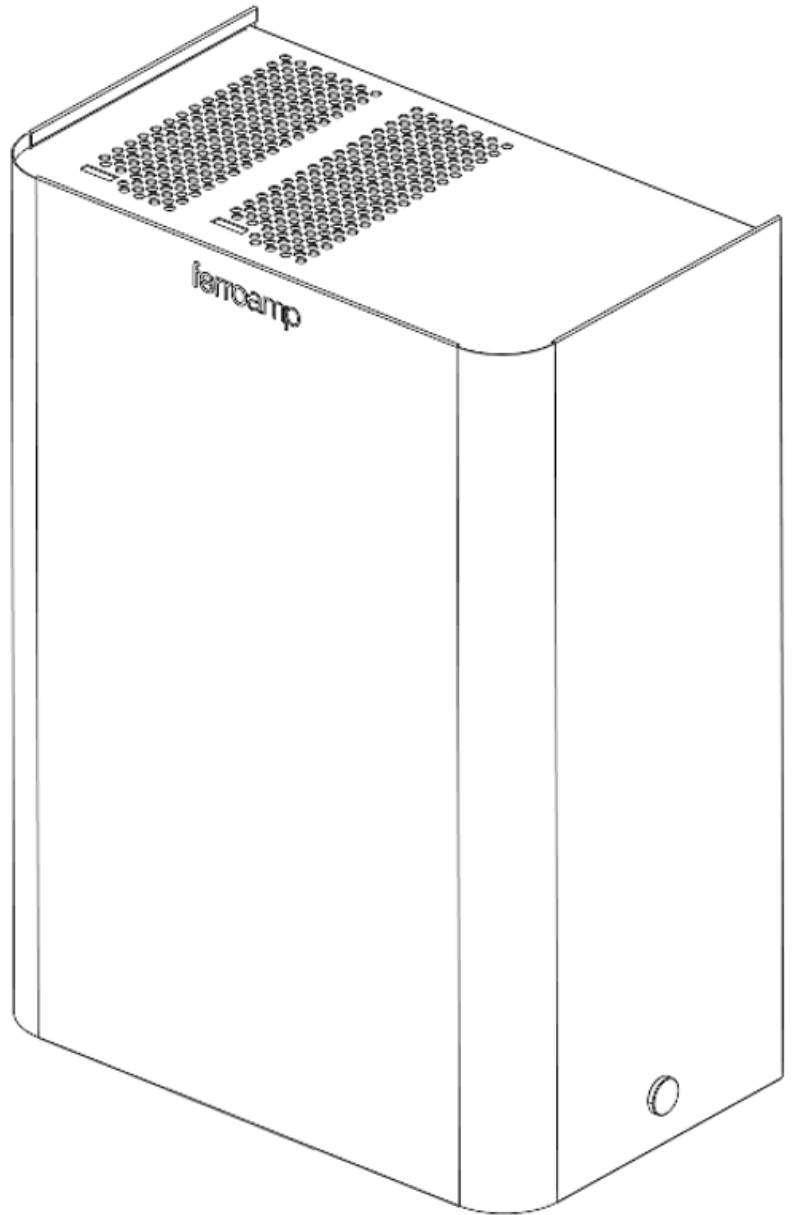

ESS Power Case

Rev A01

Table of contents

ENGLISH	1
1 Introduction.....	1
1.1 Included items	1
1.2 Warnings and recommendations	1
1.3 Explanation of safety notices	1
1.4 Dimensions	1
1.5 Bottom connections	2
1.6 Internal components & connections	2
2 Installation.....	3
2.1 Placement	3
2.1 ESS Battery connection	5
2.2 Connection of SSO:s (1-3)	6
2.3 DC nanogrid connection	7
2.4 Connection overview	7
2.5 Install ESO Modules	8
2.6 Assembly finish	9
3 Commissioning – Start up	9

Revision history

Date	Revision
2022.05.02	A01 - First release

ENGLISH

1 Introduction

In this booklet you will find installation instructions for your ESS Power Case. Please read the instructions carefully to ensure that no unnecessary errors occur.

Depending on the power configuration of the ESS System you will install the system with 1 or 2 ESO Modules (ordered separately).

1.1 Included items

The following articles are included upon delivery of a ESS Power Case:

Article	Amount
ESS Power Case	1
Mounting rod ESO Module	2
Mounting Bracket ESO Module	1
Warning sticker (En/Swe)	1/1
Warranty leaflet	1

1.2 Warnings and recommendations

RECOMMENDATION! Read through the manual before installation.

RECOMMENDATION! Only use this product according to the instructions supplied to avoid any danger.

WARNING! The electrical installations shall be conducted by authorized personnel and in accordance with local and national electrical standards and safety measures.

WARNING! You are not allowed to connect units to the DC nanogrid when it is energized.

WARNING! Risk of electrical shock/arc if the product is not used according to the instructions in the manual.

WARNING! Do not use the product if you suspect the product is damaged. Let it be inspected by qualified personnel before use.

WARNING! Do not use the product if the housing has been tampered with or not intact, for example during repair, do not touch exposed parts.

NOTE! The warranty does not apply if the product has been modified, tampered with, or not installed in accordance with this manual.

1.3 Explanation of safety notices



The flash symbol in an equilateral triangle warns of dangerous voltage.



The exclamation mark in an equilateral triangle is intended to warn the user that negligence of this information can be life threatening!



The exclamation mark in a circle is intended to inform the user that neglect of this information may be associated with bodily injury and / or damage to the product.

1.4 Dimensions

All dimensions are in mm if nothing else is specified.

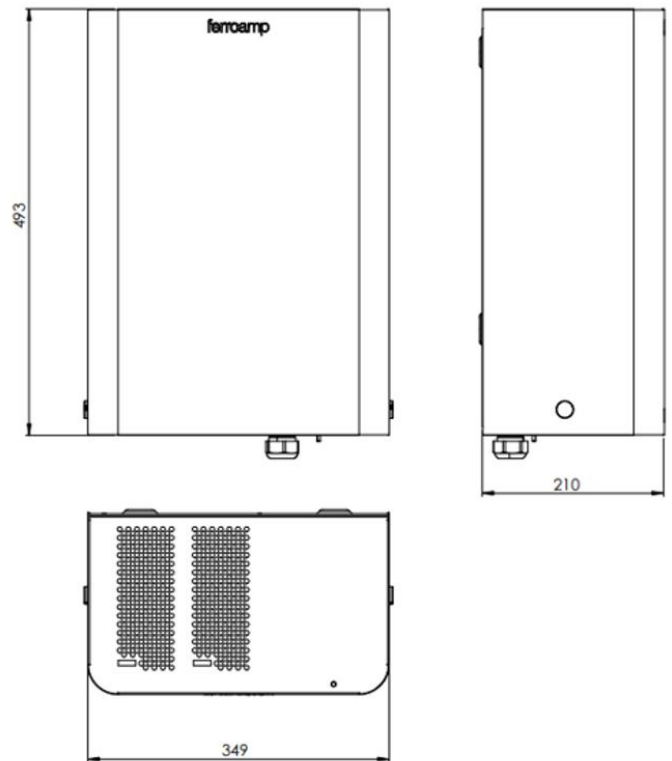

1.5 Bottom connections

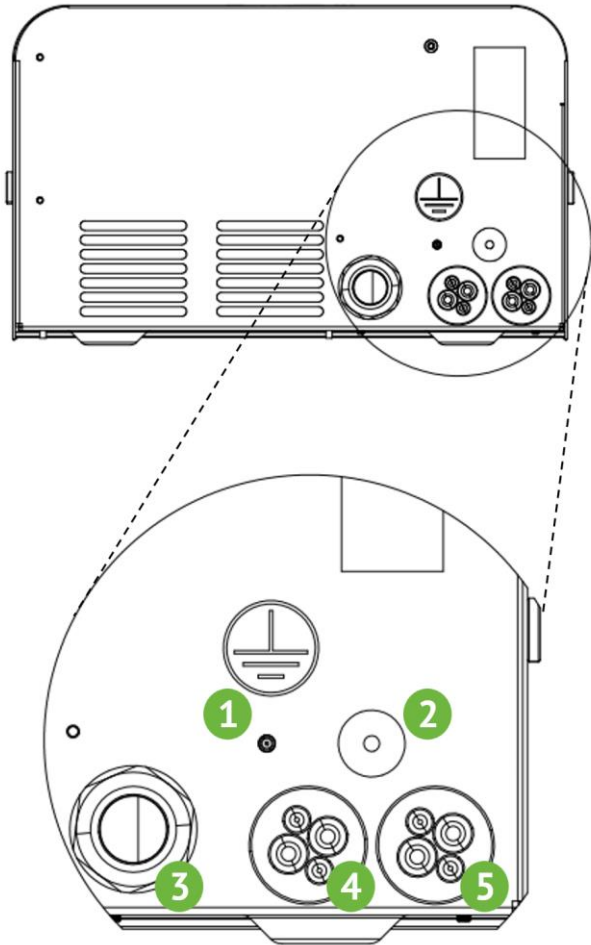

1.6 Internal components & connections

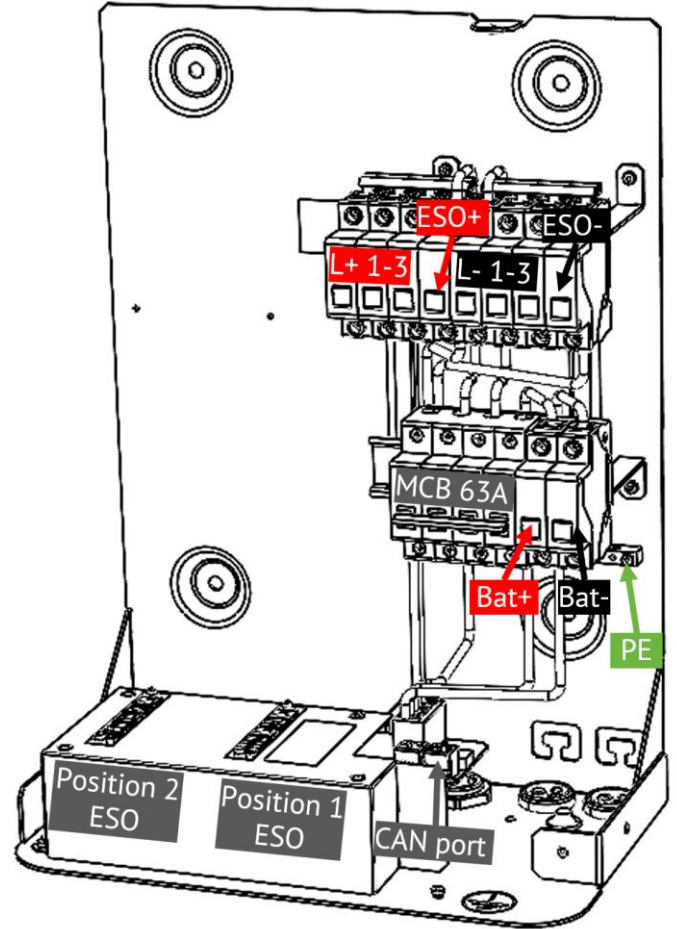

1. External ground connection (PE)
2. RJ45 cable grommet (CAN)
3. Cable gland M32 (Ø 13-21mm)
4. Multi grommet (2 x Ø 4-8mm, 2 x Ø 9-12mm)
5. Multi grommet (2 x Ø 4-8mm, 2 x Ø 9-12mm)

2 Installation

The installation section will take you step by step through the process of installing a ESS Power Case.

NOTE! Ferroamp does not take responsibility for damages on the product caused by incorrect or careless installation.

NOTE! We recommend that you use end terminals for all connection points that have multi-threaded conductors.



- Do not work alone. In an emergency, someone else's presence may be necessary!
- The electrical installation must comply with national / local laws and regulations, appropriate standards and applicable requirements from recognized organizations.



- The electrical installation must be carried out by a qualified installer and in accordance with the applicable electrical standard.
- Ensure that the location of the ESS Power Case never is an obstacle to an emergency evacuation path. In accordance with national and local laws.

2.1 Placement

NOTE! Ferroamp does not take responsibility for installations where the following stated criteria are not met.

NOTE! Make sure that the ESS Power Case and the ESS Battery are positioned close enough for the premade battery cables to reach.

Make sure that the chosen location for installation is in line with the following criteria:

- Indoor environment **protected from rain and direct sunlight**.
- Ambient temperatures must not fall below **0 °C** and not exceed **45 °C**.
- The environment must be **non-condensing, relative humidity below 95%**.
- Have free space around the ESS Power Case according to the following figures:

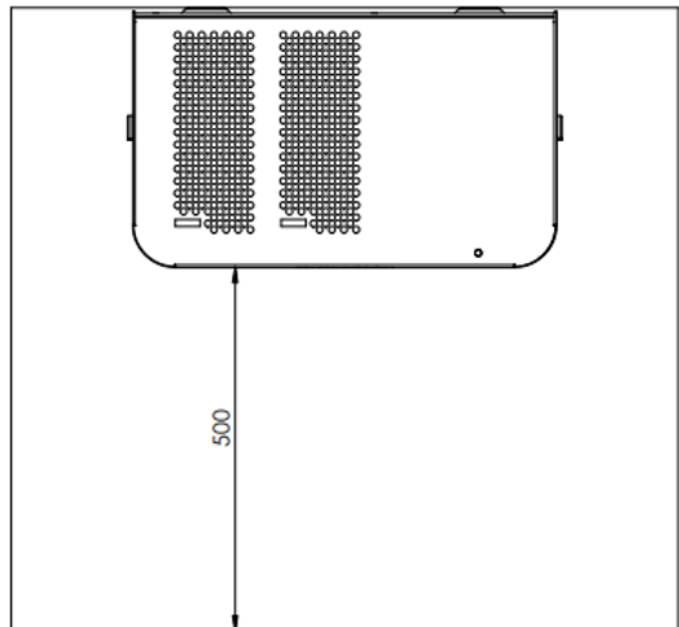
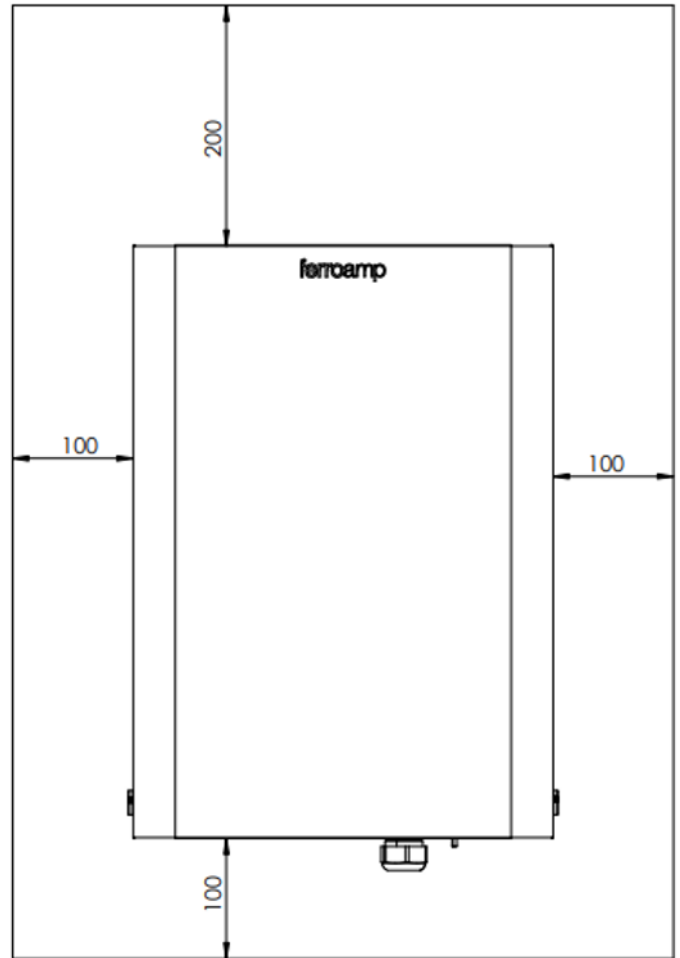

1. To remove the front cover by first unscrew the two side thumbscrews (1 & 2), slide the front up (3) and lift it off (4). Finish with unscrewing the PE-cable from the baseplate (5).

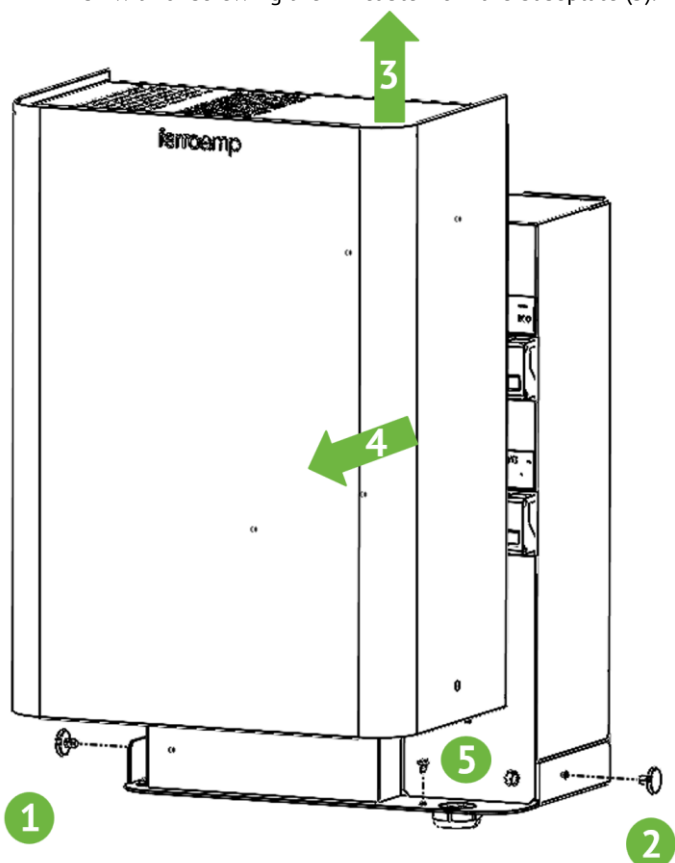

3. Mount the base plate on the wall, see dimensions for position of mounting holes (mm):

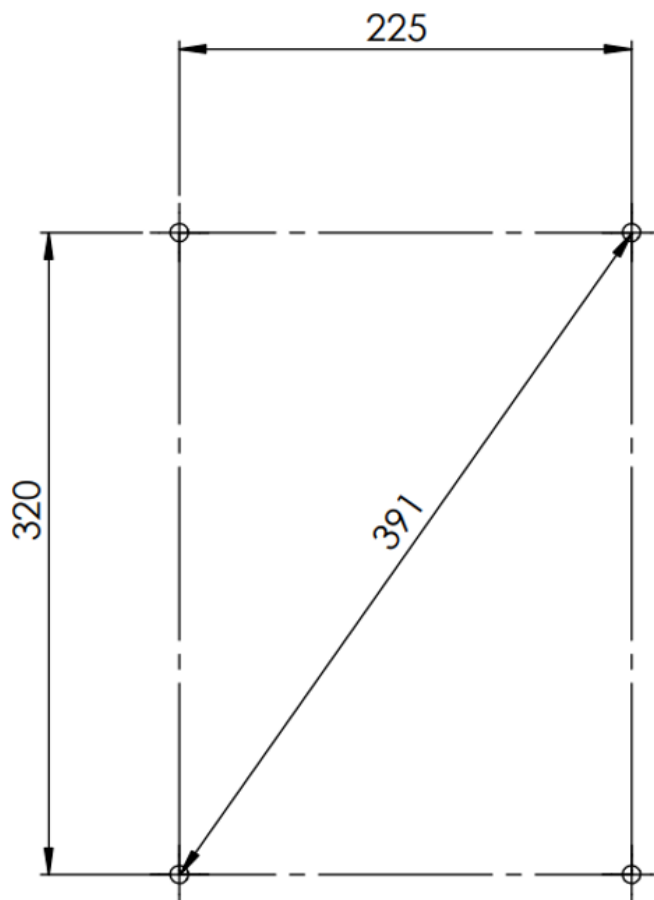

2. To access the distribution panel, unscrew the two slotted screws in the bottom front (2) and the top (3) then lift off the poke protection:

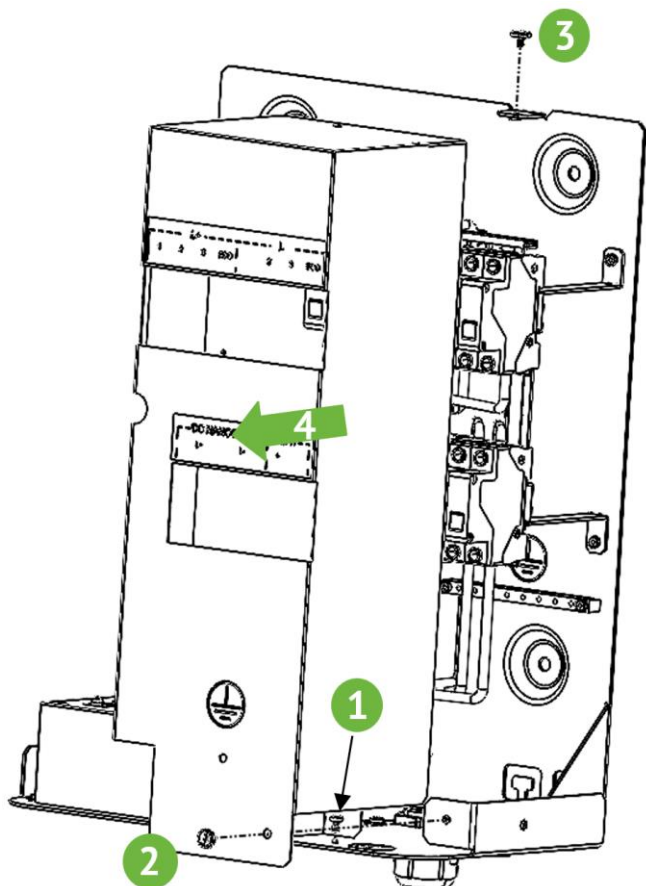

2.1 ESS Battery connection

1. Cut off the ring terminals from the premade battery cables included with the ESS Battery Controller.

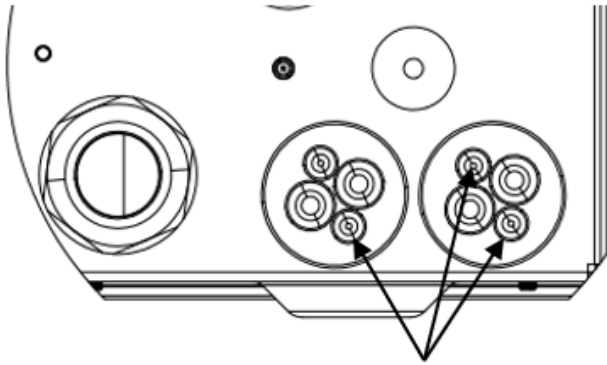

2. Poke holes in the multi grommets and feed Bat+, Bat- and PE cables through the smaller grommets.
3. Attach isolated ferrules and connect to the cables to the following terminals:

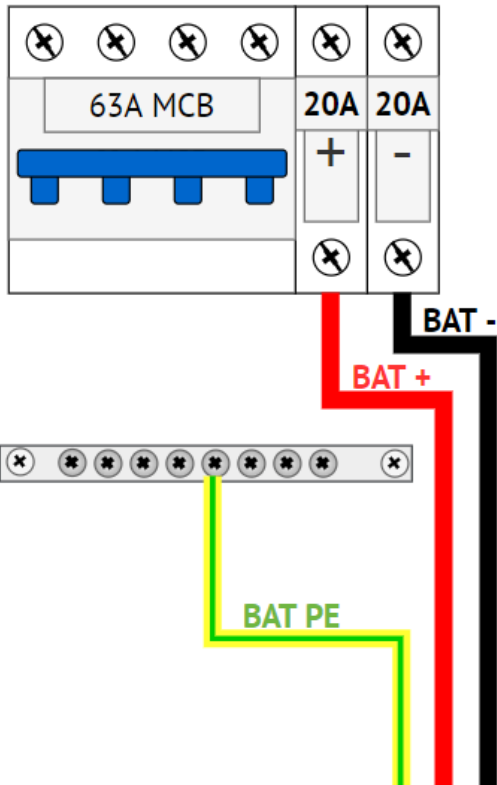

4. Make sure that all terminals are tightened to 2.5 Nm, use a torque wrench.
5. Remove the cable grommet for the RJ45 cable, poke a hole, cut it open along one side and attach it around the communication cable.

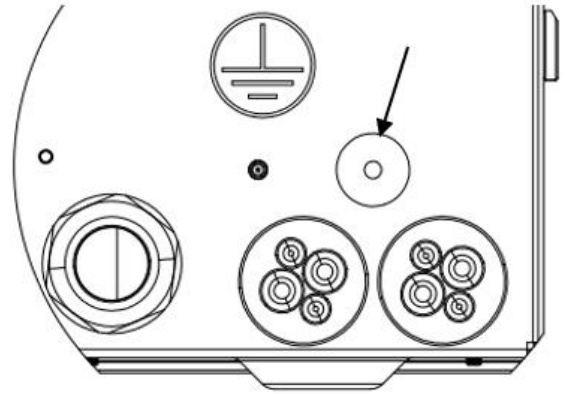

6. Connect the communication cable from the ESS Battery to the outer port, "CAN 2":

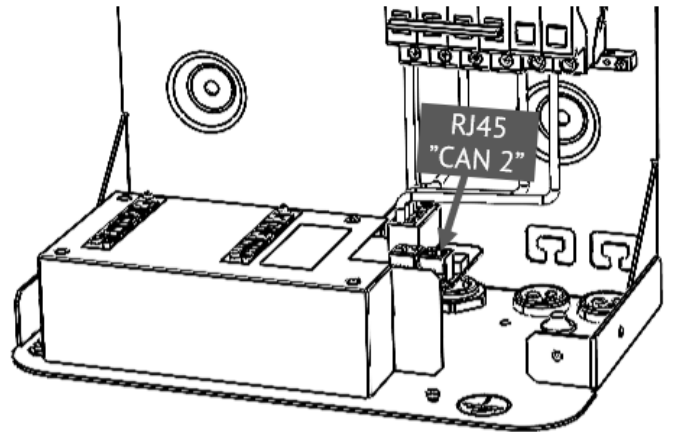

7. The ESS Battery is now connected!

2.2 Connection of SSO:s (1-3)

If you do not have any SSOs you can skip this section.

NOTE! To calculate correct cable dimensions you can use Ferroamp's online cable calculator, available at www.ferroamp.com under the support section.

1. Feed the SSO cable through one of the larger grommets:

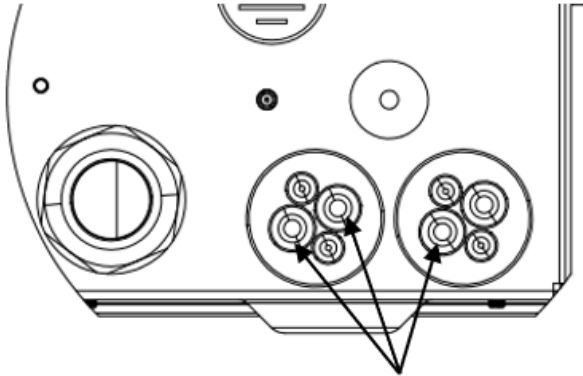

2. Feed through ~40 cm of cable for and peel of ~35 cm of isolation.

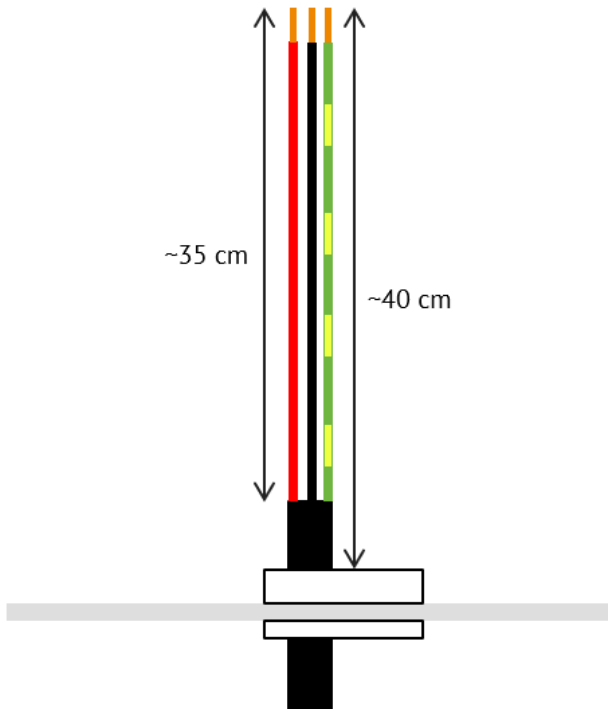

3. Connect to the following terminals:

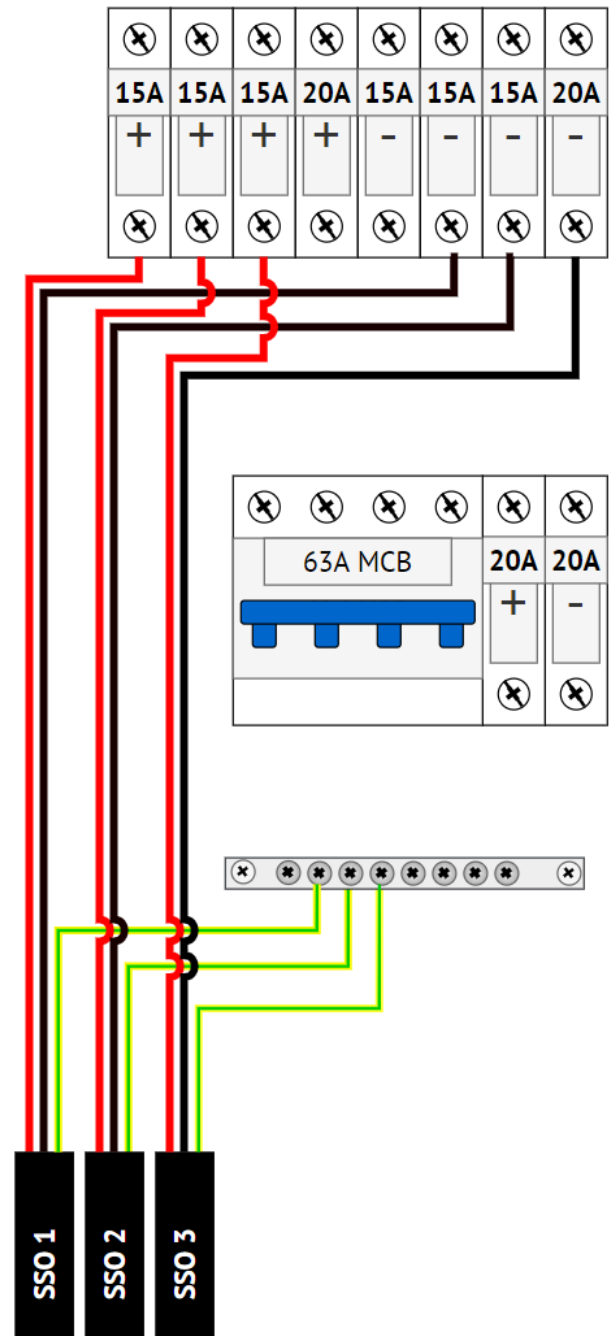

4. Make sure that all terminals are tightened to 2.5 Nm, use a torque wrench.
5. If you have 2 or 3 SSOs just repeat the steps above for each SSO.

2.3 DC nanogrid connection

NOTE! To calculate correct cable dimensions you can use Ferroamp's online cable calculator, available at www.ferroamp.com under the support section.

1. Depending on the cable diameter used for the DC link, feed the cable through the M32 cable gland or one of the larger grommets.

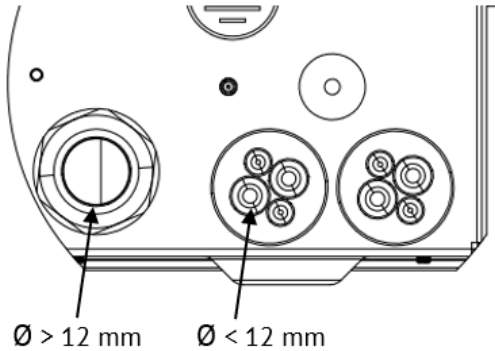

2. Peel of the cable isolation according to instruction in section 2.2.
3. Connect the DC nanogrid cable (L+, L- & PE) to the following terminals.

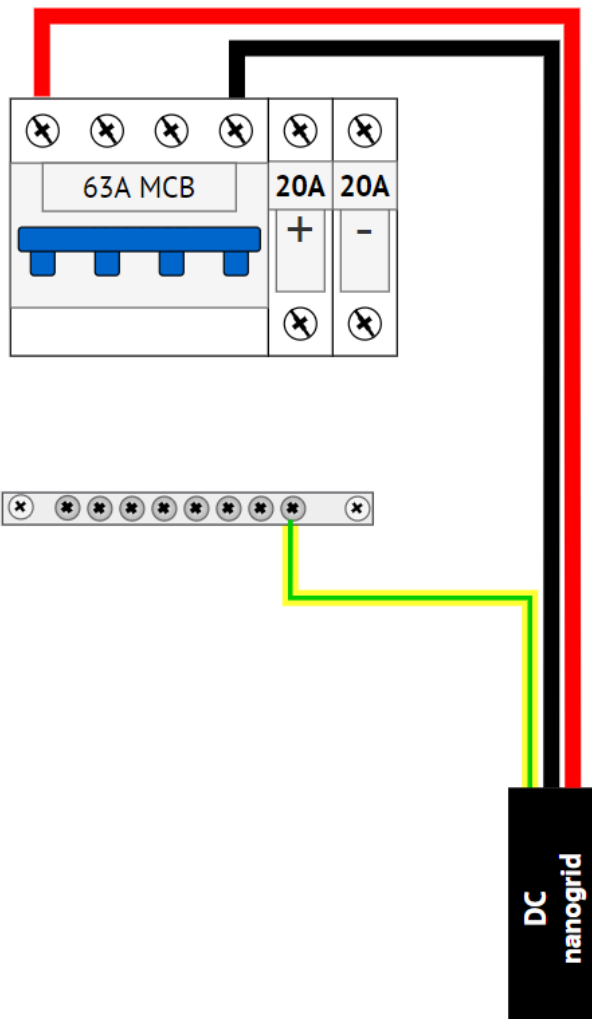

4. Make sure that all terminals are tightened to 2.5 Nm, use a torque wrench.



- Make sure that the DC nanogrid is connected to correct terminals.

2.4 Connection overview

1. Verify the correct polarity of all connected cables.
2. Control that all terminals are fastened with 2.5 Nm.

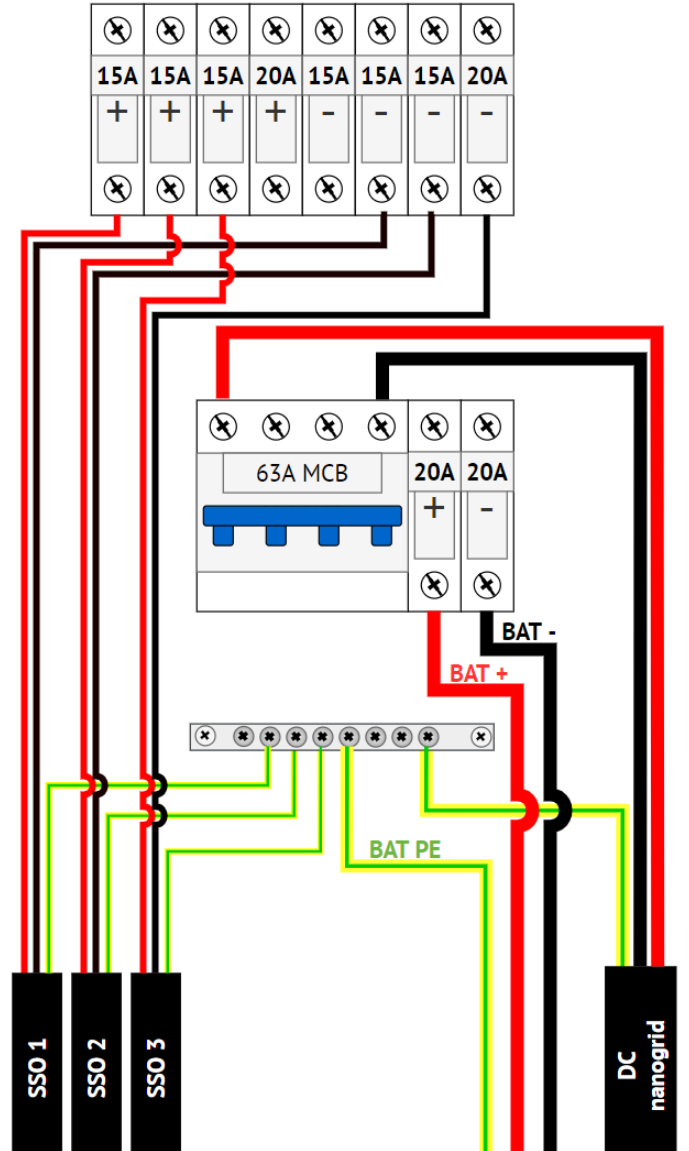

3. The key holes seen in the image below can be used to secure the cables with extra cable ties if needed.

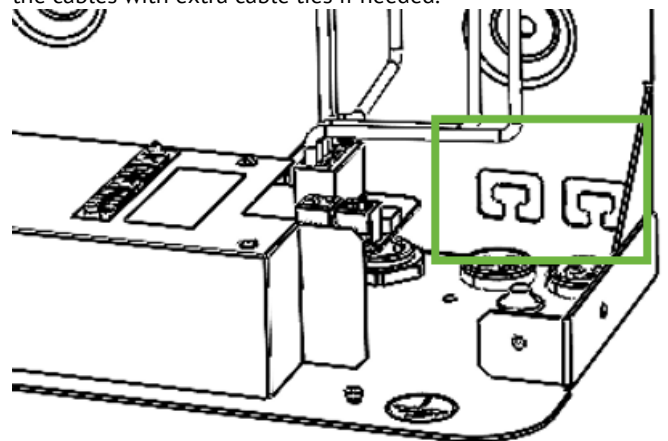

2.5 Install ESO Modules

The ESS Power Case can be configured with either 1 or 2 ESO Modules depending on the power configuration of the ESS System.

1. Unpack the ESO Module and remove the pre-installed connector (if it has one), the back connector will not be needed for the installation. To remove the connector unscrew the two screws then pull off the connector.



2. Align the ESO module against the back plate. Look from the side to ensure that the connectors are aligned.

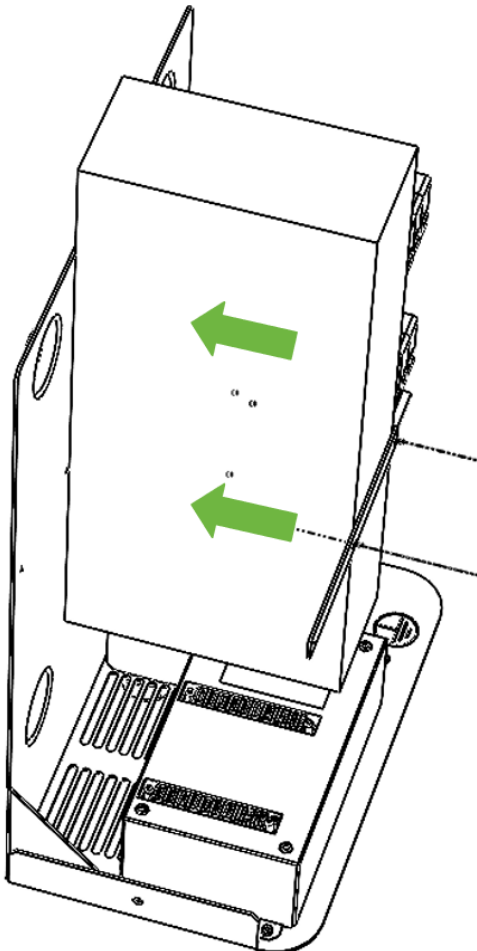

3. When alignment of the connector is good gently lower the ESO module in place, one module at the time:
 - a. 1 x ESO Module:

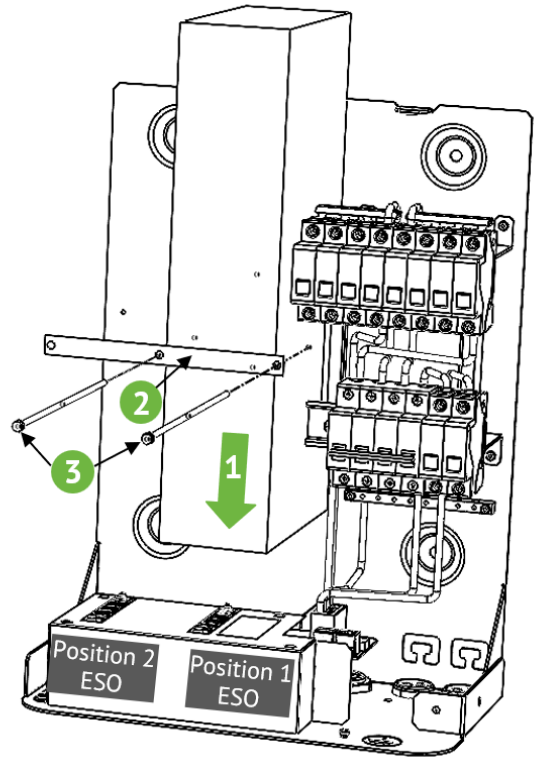

- b. 2 x ESO Module

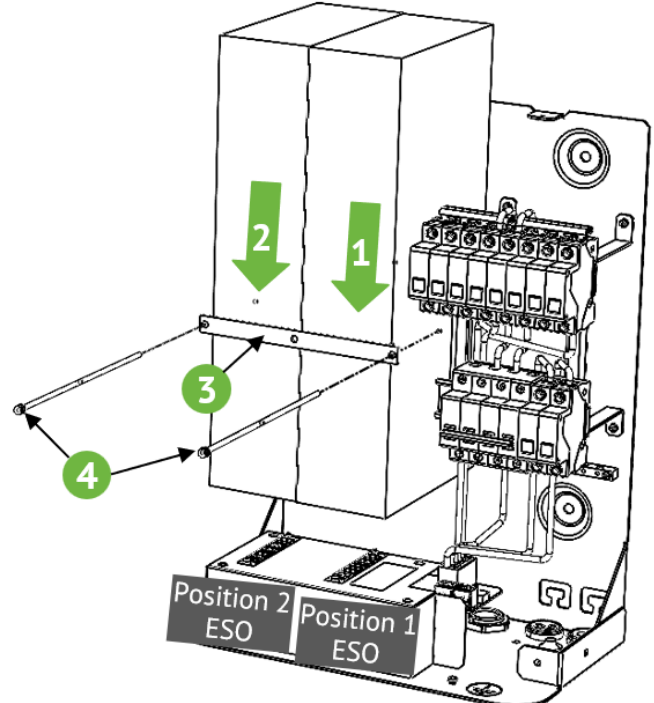

4. Secure the ESO Modules with the mounting bracket as seen in the images above.

2.6 Assembly finish

1. Mount the poke protection and re-attach the PE-cable to the base plate.

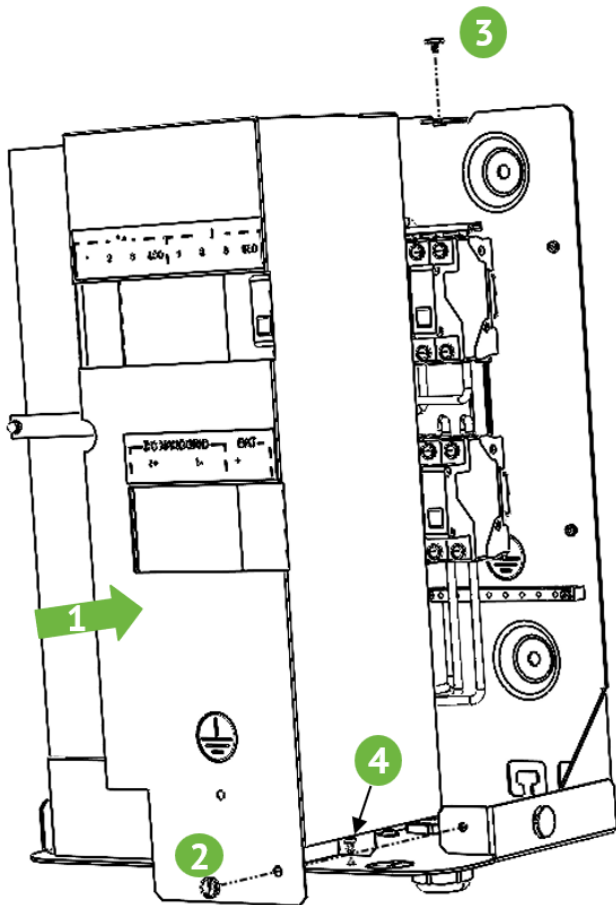

2. Attach the warning sticker on the poke protection.
3. Commission the system, see section 3.
4. Re-attach the PE cable to the baseplate before mounting the front cover.

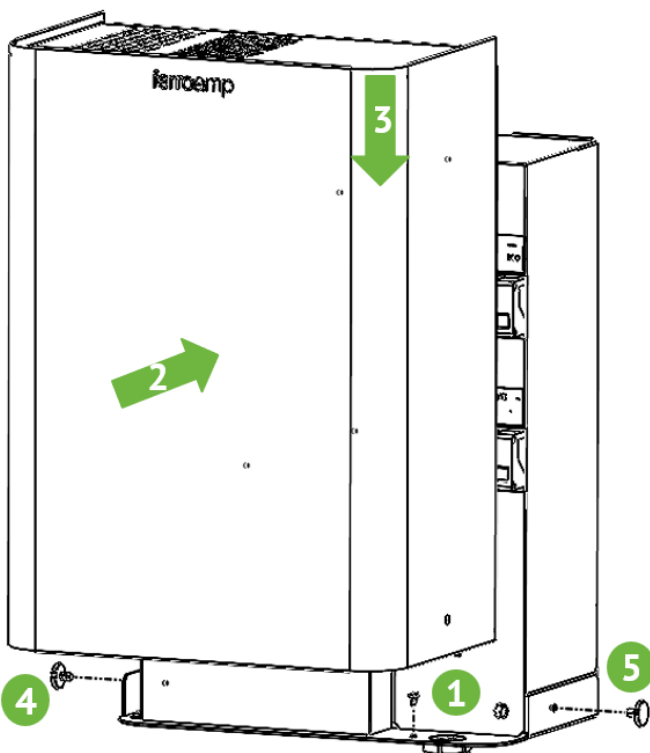

3 Commissioning – Start up

NOTE! If this is the first time starting up the EnergyHub system you need to follow the commissioning guide included with the EnergyHub (available at www.ferroamp.com).

1. Turn on the EnergyHub.
2. Close the breaker on the ESS Power Case.
3. Close the breaker on the ESS Battery and press the start button for 5 seconds until it rings.
4. When the system is on the battery will calibrate during the first 24 hours. During this time, you should set the charge reference to 1 kW in the system configuration (www.portal.ferroamp.com).
5. After the calibration has finished you can configure the battery in the system configuration after your desired use case.

ferroamp

Electricity.
Reinvented.