

LUNA2000-(97KWH-1H1, 129KWH-2H1, 161KWH-2H1, 200KWH-2H1) Smart String ESS

User Manual

Issue 14
Date 2024-03-30



Copyright © Huawei Digital Power Technologies Co., Ltd. 2024. All rights reserved.

No part of this document may be reproduced or transmitted in any form or by any means without prior written consent of Huawei Digital Power Technologies Co., Ltd.

Trademarks and Permissions



HUAWEI and other Huawei trademarks are the property of Huawei Technologies Co., Ltd.

All other trademarks and trade names mentioned in this document are the property of their respective holders.

Notice

The purchased products, services and features are stipulated by the contract made between Huawei Digital Power Technologies Co., Ltd. and the customer. All or part of the products, services and features described in this document may not be within the purchase scope or the usage scope. Unless otherwise specified in the contract, all statements, information, and recommendations in this document are provided "AS IS" without warranties, guarantees or representations of any kind, either express or implied. The information in this document is subject to change without notice. Every effort has been made in the preparation of this document to ensure accuracy of the contents, but all statements, information, and recommendations in this document do not constitute a warranty of any kind, express or implied.

Huawei Digital Power Technologies Co., Ltd.

Address: Huawei Digital Power Antuoshan Headquarters
Futian, Shenzhen 518043
People's Republic of China

Website: <https://digitalpower.huawei.com>

About This Document

Purpose

This document describes the installation, electrical connections, commissioning, and troubleshooting of LUNA2000-97KWH-1H1, LUNA2000-129KWH-2H1, LUNA2000-161KWH-2H1, and LUNA2000-200KWH-2H1 Smart String Energy Storage Systems (also referred to as ESSs). Before installing and operating the ESS, read this document carefully to understand the safety information as well as functions and features of the ESS.



Intended Audience



This document is intended for:

- Technical support engineers
- Hardware installation engineers
- Commissioning engineers
- Maintenance engineers

Symbol Conventions

The symbols that may be found in this document are defined as follows.

Symbol	Description
	Indicates a hazard with a high level of risk which, if not avoided, will result in death or serious injury.
	Indicates a hazard with a medium level of risk which, if not avoided, could result in death or serious injury.
	Indicates a hazard with a low level of risk which, if not avoided, could result in minor or moderate injury.

Symbol	Description
 NOTICE	Indicates a potentially hazardous situation which, if not avoided, could result in equipment damage, data loss, performance deterioration, or unanticipated results. NOTICE is used to address practices not related to personal injury.
 NOTE	Supplements the important information in the main text. NOTE is used to address information not related to personal injury, equipment damage, and environment deterioration.

Change History

Changes between document issues are cumulative. The latest document issue contains all the changes made in earlier issues.

Issue 14 (2024-03-30)

- Updated [1.5.2 Battery Safety](#).
- Updated [2.6.1 On-Grid Scenario](#).
- Updated [5.1 Site Selection Requirements](#).
- Updated [5.2 Clearance Requirements](#).
- Updated [7.2 Installing the ESS](#).
- Updated [7.3.1 Inside the Cabinet](#).
- Updated [7.3.2 \(Optional\) Outside the Cabinet](#).
- Updated [7.4 Installing Components](#).
- Updated [8.4 Installing Rack Controller Cables](#).
- Updated [10 Commissioning the ESS \(SmartLogger WebUI\)](#).
- Updated [10.4 Upgrading the ESS](#).
- Updated [10.6 Deployment Wizard](#).
- Updated [12.2 Power-Off Operations](#).

Issue 13 (2024-01-12)

- Added [2.6.2 Microgrid Scenario](#).
- Updated [5.3 Foundation Requirements](#).

Issue 12 (2024-01-04)

- Updated [5.1 Site Selection Requirements](#).

Updated [B How Do I Repair Paint Damage?](#).

Issue 11 (2023-12-21)

Updated [5.2 Clearance Requirements](#).

Updated [5.4 Forklift Requirements](#).

Updated [7.2 Installing the ESS](#).

Updated [7.4.2 Installing Battery Packs](#).

Updated [7.4.3 Installing the Smart Rack Controller](#).

Updated [8.4 Installing Rack Controller Cables](#).

Issue 10 (2023-11-07)

Updated [2.2 Product Description](#).

Updated [7.4.3 Installing the Smart Rack Controller](#).

Updated [10.1 Preparations and WebUI Login](#).

Updated [10.2 Checking the SmartLogger Software Version](#).

Updated [10.3 Upgrading the SmartLogger](#).

Updated [10.4 Upgrading the ESS](#).

Updated [10.6 Deployment Wizard](#).

Added [10.8 Setting the System Antitheft Function](#).

Updated [E CMU Commissioning](#).

Added [F Certificate Management and Maintenance](#).

Issue 09 (2023-10-24)

Updated [2 Product Description](#).

Added [2.2 Product Description](#).

Updated [4.2 Battery Pack Storage and Single Battery Pack Charge](#).

Updated [8.7 Installing AC Input Power Cables for the UPS](#).

Issue 08 (2023-08-18)

Updated [8.3 Installing Battery Pack Cables](#).

Issue 07 (2023-08-07)

Updated [10.6 Deployment Wizard](#).

Added [H Digital Power Customer Service](#).

Issue 06 (2023-07-20)

- Updated [2.1 Model Description](#).
- Updated [2.5.1 Circuit Diagram](#).
- Updated [2.6.1 On-Grid Scenario](#).
- Updated [14 Technical Specifications](#).

Issue 05 (2023-06-30)

- Updated [2.1 Model Description](#).
- Updated [2.4 Components](#).
- Updated [2.6.1 On-Grid Scenario](#).
- Updated [7.4 Installing Components](#).
- Updated [7.4.2 Installing Battery Packs \(Using a Ball Transfer Platform\)](#).
- Updated [7.4.3 Installing the Smart Rack Controller](#).
- Updated [8.3 Installing Battery Pack Cables](#).
- Updated [8.4 Installing Rack Controller Cables](#).
- Updated [10.4 Upgrading the ESS](#).
- Updated [14 Technical Specifications](#).

Issue 04 (2023-06-10)

- Updated [5.1 Site Selection Requirements](#).
- Updated [10 Commissioning the ESS \(SmartLogger WebUI\)](#).
- Updated [G Contact Information](#).

Issue 03 (2023-03-30)

- Updated [2.3 Appearance](#).
- Updated [2.4.3.1 Air Conditioner](#).
- Updated [5.1 Site Selection Requirements](#).
- Updated [5.2 Clearance Requirements](#).
- Updated [5.3 Foundation Requirements](#).
- Updated [5.4 Forklift Requirements](#).
- Updated [10.2 Checking the SmartLogger Software Version](#).
- Updated [10.3 Upgrading the SmartLogger](#).
- Updated [10.4 Upgrading the ESS](#).

Issue 02 (2023-02-28)

Added [5.2 Clearance Requirements](#).

Added [5.3 Foundation Requirements](#).

Updated [1 Safety Information](#).

Updated [2.3 Appearance](#).

Updated [4 Storage Requirements](#).

Updated [5.1 Site Selection Requirements](#).

Updated [5.4 Forklift Requirements](#).

Updated [8.6 Installing AC Power Cables for Auxiliary Power Supply](#).

Updated [8.7 Installing AC Input Power Cables for the UPS](#).

Updated [14 Technical Specifications](#).

Updated [C Emergency Handling](#).

Issue 01 (2022-10-30)

This issue is used for first office application (FOA).

Contents

About This Document.....	ii
1 Safety Information.....	1
1.1 Personal Safety.....	2
1.2 Electrical Safety.....	4
1.3 Environment Requirements.....	7
1.4 Mechanical Safety.....	9
1.5 Equipment Safety.....	13
1.5.1 ESS Safety.....	14
1.5.2 Battery Safety.....	14
2 Product Description.....	21
2.1 Model Description.....	21
2.2 Product Description.....	22
2.3 Appearance.....	22
2.4 Components.....	24
2.4.1 Power Supply and Distribution System.....	30
2.4.1.1 Battery Pack.....	30
2.4.1.2 Smart Rack Controller.....	32
2.4.1.3 Embedded Power Subrack.....	35
2.4.1.4 Monitoring Module (SMU11B).....	35
2.4.1.5 PSU.....	36
2.4.2 Monitoring System.....	38
2.4.2.1 Central Monitoring Unit (CMU).....	39
2.4.2.2 I/O Expansion Board.....	40
2.4.3 Environment Control System.....	41
2.4.3.1 Air Conditioner.....	42
2.4.3.2 T/H Sensor.....	43
2.4.3.3 Door Status Sensor.....	44
2.4.3.4 Electrode Water Sensor.....	45
2.4.4 Fire Suppression System.....	46
2.4.4.1 Rack Mounted Fire Extinguishing System.....	46
2.4.4.2 T/H Sensor.....	48
2.4.4.3 CO Sensor.....	49

2.4.4.4 Smoke Detector.....	50
2.4.5 Exhaust System.....	51
2.4.5.1 Exhaust Module.....	52
2.4.5.2 Exhaust Controller.....	52
2.5 Working Principle.....	53
2.5.1 Circuit Diagram.....	54
2.5.2 Device Status.....	54
2.6 Networking Application.....	55
2.6.1 On-Grid Scenario.....	55
2.6.2 Microgrid Scenario.....	58
3 Transportation Requirements.....	59
4 Storage Requirements.....	62
4.1 ESS (Excluding Battery Packs) Storage.....	62
4.2 Battery Pack Storage and Single Battery Pack Charge.....	62
4.3 Smart Rack Controller Storage.....	67
5 Site Requirements.....	69
5.1 Site Selection Requirements.....	69
5.1.1 General Requirements.....	69
5.1.2 Outdoor Requirements.....	70
5.1.3 Indoor Requirements.....	72
5.2 Clearance Requirements.....	74
5.3 Foundation Requirements.....	75
5.4 Forklift Requirements.....	76
5.5 Hoisting Requirements.....	77
6 Unpacking and Acceptance.....	79
7 Installation.....	80
7.1 Installation Preparations.....	80
7.1.1 Preparing Tools.....	80
7.1.2 Pre-installation Check.....	83
7.2 Installing the ESS.....	83
7.3 Connecting a Ground Cable for the ESS.....	87
7.3.1 Inside the Cabinet.....	87
7.3.2 (Optional) Outside the Cabinet.....	88
7.4 Installing Components.....	90
7.4.1 Installing the Rack Mounted Fire Extinguishing System.....	91
7.4.2 Installing Battery Packs.....	92
7.4.2.1 Installation Kit.....	92
7.4.2.2 Installing Battery Packs (Using a Ball Transfer Platform).....	94
7.4.2.3 Installing Battery Packs (Using a Sliding Rack Shelf).....	101
7.4.3 Installing the Smart Rack Controller.....	111

7.4.4 Installing the Smart PCS.....	115
7.4.5 (Optional) Installing a Maintenance Socket.....	117
7.4.6 (Optional) Installing a DDSU666-H.....	118
8 Installing Cables.....	119
8.1 Preparing Cables.....	120
8.2 Installing Cables for the Rack Mounted Fire Extinguishing System.....	122
8.3 Installing Battery Pack Cables.....	122
8.4 Installing Rack Controller Cables.....	130
8.5 Installing a DC Power Cable.....	133
8.6 Installing AC Power Cables for Auxiliary Power Supply.....	134
8.7 Installing AC Input Power Cables for the UPS.....	135
8.8 Installing Communications Cables.....	136
8.8.1 Installing an FE Communications Cable.....	136
8.8.2 Installing Fiber Ring Network Communications Cables.....	137
8.9 (Optional) Installing DDSU666-H Cables.....	140
8.10 (Optional) Installing Maintenance Socket Cables.....	141
8.11 Sealing Cable Holes.....	141
9 Powering On the ESS.....	142
9.1 Check Before Power-On.....	142
9.1.1 General Check.....	142
9.1.2 ESS Installation Check.....	143
9.2 Installing a PSU.....	144
9.3 Power-On Operations.....	145
10 Commissioning the ESS (SmartLogger WebUI).....	148
10.1 Preparations and WebUI Login.....	148
10.2 Checking the SmartLogger Software Version.....	152
10.3 Upgrading the SmartLogger.....	153
10.4 Upgrading the ESS.....	153
10.5 System Startup.....	155
10.6 Deployment Wizard.....	156
10.7 Checking Alarms.....	167
10.8 Setting the System Antitheft Function.....	168
11 Closing Cabinet Doors.....	170
12 Powering Off the ESS.....	171
12.1 Sending a Shutdown Command on the SmartLogger.....	171
12.2 Power-Off Operations.....	172
13 Alarm Reference.....	173
14 Technical Specifications.....	174
A Crimping an OT or DT Terminal.....	176

B How Do I Repair Paint Damage?	179
C Emergency Handling	184
D How Do I Recycle Used Batteries?	187
E CMU Commissioning	188
E.1 CMU Operations on the WebUI.....	188
E.1.1 CMU WebUI Operations.....	188
E.1.1.1 Introduction to the WebUI.....	188
E.1.1.2 WebUI Layout.....	188
E.1.1.3 Icon Description.....	189
E.1.1.4 WebUI Menus.....	190
E.1.2 Maintenance Operations.....	192
E.1.2.1 Preparations and WebUI Login.....	192
E.1.2.2 Upgrading the Software Version.....	196
E.1.2.3 Exporting Device Logs.....	197
E.1.2.4 Checking Alarms.....	198
E.1.2.5 Clearing Alarms.....	198
E.2 App Operations.....	199
E.2.1 Downloading and Installing the App.....	199
E.2.2 Logging In to the App.....	200
E.2.3 Changing a Password.....	202
F Certificate Management and Maintenance	203
G Contact Information	205
H Digital Power Customer Service	207
I Acronyms and Abbreviations	208

1 Safety Information

Statement

Before transporting, storing, installing, operating, using, and/or maintaining the equipment, read this document, strictly follow the instructions provided herein, and follow all the safety instructions on the equipment and in this document. In this document, "equipment" refers to the products, software, components, spare parts, and/or services related to this document; "the Company" refers to the manufacturer (producer), seller, and/or service provider of the equipment; "you" refers to the entity that transports, stores, installs, operates, uses, and/or maintains the equipment.

The **Danger, Warning, Caution, and Notice** statements described in this document do not cover all the safety precautions. You also need to comply with relevant international, national, or regional standards and industry practices. **The Company shall not be liable for any consequences that may arise due to violations of safety requirements or safety standards concerning the design, production, and usage of the equipment.**

The equipment shall be used in an environment that meets the design specifications. Otherwise, the equipment may be faulty, malfunctioning, or damaged, which is not covered under the warranty. The Company shall not be liable for any property loss, personal injury, or even death caused thereby.

Comply with applicable laws, regulations, standards, and specifications during transportation, storage, installation, operation, use, and maintenance.

Do not perform reverse engineering, decompilation, disassembly, adaptation, implantation, or other derivative operations on the equipment software. Do not study the internal implementation logic of the equipment, obtain the source code of the equipment software, violate intellectual property rights, or disclose any of the performance test results of the equipment software.

The Company shall not be liable for any of the following circumstances or their consequences:

- The equipment is damaged due to force majeure such as earthquakes, floods, volcanic eruptions, debris flows, lightning strikes, fires, wars, armed conflicts, typhoons, hurricanes, tornadoes, and other extreme weather conditions.
- The equipment is operated beyond the conditions specified in this document.

- The equipment is installed or used in environments that do not comply with international, national, or regional standards.
- The equipment is installed or used by unqualified personnel.
- You fail to follow the operation instructions and safety precautions on the product and in the document.
- You remove or modify the product or modify the software code without authorization.
- You or a third party authorized by you cause the equipment damage during transportation.
- The equipment is damaged due to storage conditions that do not meet the requirements specified in the product document.
- You fail to prepare materials and tools that comply with local laws, regulations, and related standards.
- The equipment is damaged due to your or a third party's negligence, intentional breach, gross negligence, or improper operations, or other reasons not related to the Company.

1.1 Personal Safety

 **DANGER**

Ensure that power is off during installation. Do not install or remove a cable with power on. Transient contact between the core of the cable and the conductor will cause electric arcs, sparks, fire, or explosion, which may result in personal injury.

 **DANGER**

Non-standard and improper operations on the energized equipment may cause fire, electric shocks, or explosion, resulting in property damage, personal injury, or even death.

 **DANGER**

Before operations, remove conductive objects such as watches, bracelets, bangles, rings, and necklaces to prevent electric shocks.

 **DANGER**

During operations, use dedicated insulated tools to prevent electric shocks or short circuits. The dielectric withstanding voltage level must comply with local laws, regulations, standards, and specifications.

 **WARNING**

During operations, wear personal protective equipment such as protective clothing, insulated shoes, goggles, safety helmets, and insulated gloves.

General Requirements

- Do not stop protective devices. Pay attention to the warnings, cautions, and related precautionary measures in this document and on the equipment.
- If there is a likelihood of personal injury or equipment damage during operations, immediately stop, report the case to the supervisor, and take feasible protective measures.
- Do not power on the equipment before it is installed or confirmed by professionals.
- Do not touch the power supply equipment directly or with conductors such as damp objects. Before touching any conductor surface or terminal, measure the voltage at the contact point to ensure that there is no risk of electric shock.
- Do not touch operating equipment because the enclosure is hot.
- Do not touch a running fan with your hands, components, screws, tools, or boards. Otherwise, personal injury or equipment damage may occur.
- In the case of a fire, immediately leave the building or the equipment area and activate the fire alarm or call emergency services. Do not enter the affected building or equipment area under any circumstances.

Personnel Requirements

- Only professionals and trained personnel are allowed to operate the equipment.
 - Professionals: personnel who are familiar with the working principles and structure of the equipment, trained or experienced in equipment operations and are clear of the sources and degree of various potential hazards in equipment installation, operation, maintenance
 - Trained personnel: personnel who are trained in technology and safety, have required experience, are aware of possible hazards on themselves in certain operations, and are able to take protective measures to minimize the hazards on themselves and other people
- Personnel who plan to install or maintain the equipment must receive adequate training, be able to correctly perform all operations, and understand all necessary safety precautions and local relevant standards.
- Only qualified professionals or trained personnel are allowed to install, operate, and maintain the equipment.
- Only qualified professionals are allowed to remove safety facilities and inspect the equipment.
- Personnel who will perform special tasks such as electrical operations, working at heights, and operations of special equipment must possess the required local qualifications.
- Only certified high-voltage electricians are allowed to operate medium-voltage equipment.

- Only authorized professionals are allowed to replace the equipment or components (including software).
- Only personnel who need to work on the equipment are allowed to access the equipment.

1.2 Electrical Safety

 **DANGER**

Before connecting cables, ensure that the equipment is intact. Otherwise, electric shocks or fire may occur.

 **DANGER**

Non-standard and improper operations may result in fire or electric shocks.

 **DANGER**

Prevent foreign matter from entering the equipment during operations. Otherwise, equipment damage, load power derating, power failure, or personal injury may occur.

 **WARNING**

For the equipment that needs to be grounded, install the ground cable first when installing the equipment and remove the ground cable last when removing the equipment.

 **CAUTION**

Do not route cables near the air intake or exhaust vents of the equipment.

General Requirements

- Follow the procedures described in the document for installation, operation, and maintenance. Do not reconstruct or alter the equipment, add components, or change the installation sequence without permission.
- Obtain approval from the national or local electric utility company before connecting the equipment to the grid.
- Observe the power plant safety regulations, such as the operation and work ticket mechanisms.
- Install temporary fences or warning ropes and hang "No Entry" signs around the operation area to keep unauthorized personnel away from the area.

- Before installing or removing power cables, turn off the switches of the equipment and its upstream and downstream switches.
- If any liquid is detected inside the equipment, disconnect the power supply immediately and do not use the equipment.
- Before performing operations on the equipment, check that all tools meet the requirements and record the tools. After the operations are complete, collect all of the tools to prevent them from being left inside the equipment.
- Before installing power cables, check that cable labels are correct and cable terminals are insulated.
- When installing the equipment, use a torque tool of a proper measurement range to tighten the screws. When using a wrench to tighten the screws, ensure that the wrench does not tilt and the torque error does not exceed 10% of the specified value.
- Ensure that bolts are tightened with a torque tool and marked in red and blue after double-check. Installation personnel mark tightened bolts in blue. Quality inspection personnel confirm that the bolts are tightened and then mark them in red. (The marks must cross the edges of the bolts.)

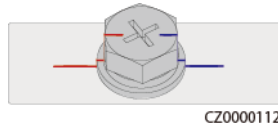

- After the installation is complete, ensure that protective cases, insulation tubes, and other necessary items for all electrical components are in position to avoid electric shocks.
- If the equipment has multiple inputs, disconnect all the inputs before operating the equipment.
- Before maintaining a downstream electrical or power distribution device, turn off the output switch on the power supply equipment.
- During equipment maintenance, attach "Do not switch on" labels near the upstream and downstream switches or circuit breakers as well as warning signs to prevent accidental connection. The equipment can be powered on only after troubleshooting is complete.
- If fault diagnosis and troubleshooting need to be performed after power-off, take the following safety measures: Disconnect the power supply. Check whether the equipment is live. Install a ground cable. Hang warning signs and set up fences.
- Check equipment connections periodically, ensuring that all screws are securely tightened.
- Only qualified professionals can replace a damaged cable.
- Do not scrawl, damage, or block any labels or nameplates on the equipment. Promptly replace labels that have worn out.
- Do not use solvents such as water, alcohol, or oil to clean electrical components inside or outside of the equipment.

Grounding

- Ensure that the grounding impedance of the equipment complies with local electrical standards.

- Ensure that the equipment is connected permanently to the protective ground. Before operating the equipment, check its electrical connection to ensure that it is reliably grounded.
- Do not work on the equipment in the absence of a properly installed ground conductor.
- Do not damage the ground conductor.
- For the equipment that uses a three-pin socket, ensure that the ground terminal in the socket is connected to the protective ground point.
- If high touch current may occur on the equipment, ground the protective ground terminal on the equipment enclosure before connecting the power supply; otherwise, electric shock as a result of touch current may occur.

Cabling Requirements

- When selecting, installing, and routing cables, follow local safety regulations and rules.
- When routing power cables, ensure that there is no coiling or twisting. Do not join or weld power cables. If necessary, use a longer cable.
- Ensure that all cables are properly connected and insulated, and meet specifications.
- Ensure that the slots and holes for routing cables are free from sharp edges, and that the positions where cables are routed through pipes or cable holes are equipped with cushion materials to prevent the cables from being damaged by sharp edges or burrs.
- If a cable is routed into the cabinet from the top, bend the cable in a U shape outside the cabinet and then route it into the cabinet.
- Ensure that cables of the same type are bound together neatly and straight and that the cable sheath is intact. When routing cables of different types, ensure that they are at least 30 mm away from each other.
- When cable connection is completed or paused for a short period of time, seal the cable holes with sealing putty immediately to prevent small animals or moisture from entering.
- Secure buried cables using cable supports and cable clips. Ensure that the cables in the backfill area are in close contact with the ground to prevent cable deformation or damage during backfilling.
- If the external conditions (such as the cable layout or ambient temperature) change, verify the cable usage in accordance with the IEC-60364-5-52 or local laws and regulations. For example, check that the current-carrying capacity meets requirements.
- When routing cables, reserve at least 30 mm clearance between the cables and heat-generating components or areas. This prevents deterioration or damage to the cable insulation layer.
- When the temperature is low, violent impact or vibration may damage the plastic cable sheathing. To ensure safety, comply with the following requirements:
 - Cables can be laid or installed only when the temperature is higher than 0°C. Handle cables with caution, especially at a low temperature.
 - Cables stored at below 0°C must be stored at room temperature for more than 24 hours before they are laid out.

- Do not perform any improper operations, for example, dropping cables directly from a vehicle. Otherwise, the cable performance may deteriorate due to cable damage, which affects the current-carrying capacity and temperature rise.

ESD

NOTICE

The static electricity generated by human bodies may damage the electrostatic-sensitive components on boards, for example, the large-scale integrated (LSI) circuits.

- When touching the equipment and handling boards, modules with exposed circuit boards, or application-specific integrated circuits (ASICs), observe ESD protection regulations and wear ESD clothing and ESD gloves or a well-grounded ESD wrist strap.

Figure 1-1 Wearing an ESD wrist strap

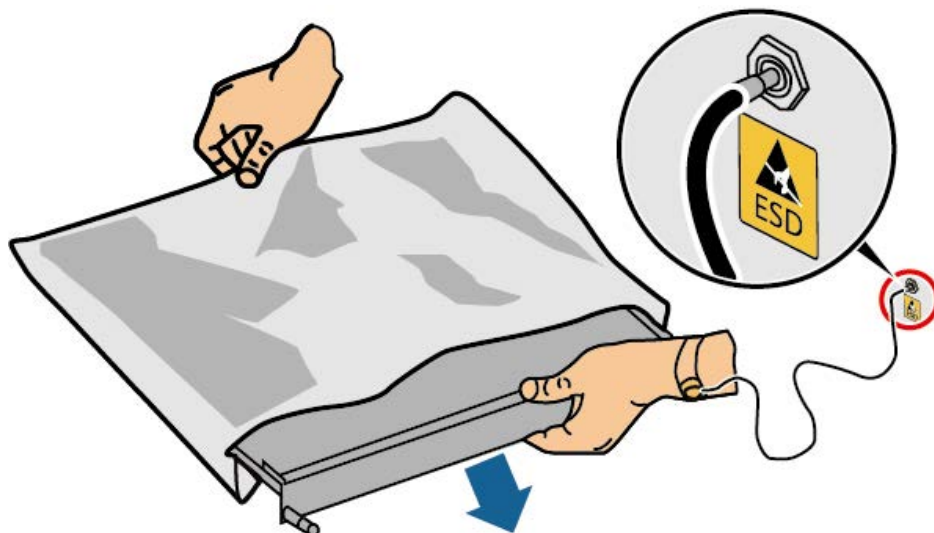

DC15000001

- When holding a board or a module with exposed circuit boards, hold its edge without touching any components. Do not touch the components with bare hands.
- Package boards or modules with ESD packaging materials before storing or transporting them.

1.3 Environment Requirements

DANGER

Do not expose the equipment to flammable or explosive gas or smoke. Do not perform any operation on the equipment in such environments.

 **DANGER**

Do not store any flammable or explosive materials in the equipment area.

 **DANGER**

Do not place the equipment near heat sources or fire sources, such as smoke, candles, heaters, or other heating devices. Overheat may damage the equipment or cause a fire.

 **WARNING**

Install the equipment in an area far away from liquids. Do not install it under areas prone to condensation, such as under water pipes and air exhaust vents, or areas prone to water leakage, such as air conditioner vents, ventilation vents, or feeder windows of the equipment room. Ensure that no liquid enters the equipment to prevent faults or short circuits.

 **WARNING**

To prevent damage or fire due to high temperature, ensure that the ventilation vents or heat dissipation systems are not obstructed or covered by other objects while the equipment is running.

General Requirements

- Ensure that the equipment is stored in a clean, dry, and well ventilated area with proper temperature and humidity and is protected from dust and condensation.
- Keep the installation and operating environments of the equipment within the allowed ranges. Otherwise, its performance and safety will be compromised.
- Do not install, use, or operate outdoor equipment and cables (including but not limited to moving equipment, operating equipment and cables, inserting connectors to or removing connectors from signal ports connected to outdoor facilities, working at heights, performing outdoor installation, and opening doors) in harsh weather conditions such as lightning, rain, snow, and level 6 or stronger wind.
- Do not install the equipment in an environment with dust, smoke, volatile or corrosive gases, infrared and other radiations, organic solvents, or salty air.
- Do not install the equipment in an environment with conductive metal or magnetic dust.
- Do not install the equipment in an area conducive to the growth of microorganisms such as fungus or mildew.
- Do not install the equipment in an area with strong vibration, noise, or electromagnetic interference.

- Ensure that the site complies with local laws, regulations, and related standards.
- Ensure that the ground in the installation environment is solid, free from spongy or soft soil, and not prone to subsidence. The site must not be located in a low-lying land prone to water or snow accumulation, and the horizontal level of the site must be above the highest water level of that area in history.
- Do not install the equipment in a position that may be submerged in water.
- If the equipment is installed in a place with abundant vegetation, in addition to routine weeding, harden the ground underneath the equipment using cement or gravel.
- Before opening doors during the installation, operation, and maintenance of the equipment, clean up any water, ice, snow, or other foreign objects on the top of the equipment to prevent foreign objects from falling into the equipment.
- When installing the equipment, ensure that the installation surface is solid enough to bear the weight of the equipment.
- All cable holes must be sealed. Seal the used cable holes with sealing putty. Seal the unused cable holes with the caps delivered with the equipment. The following figure shows the criteria for correct sealing with sealing putty.

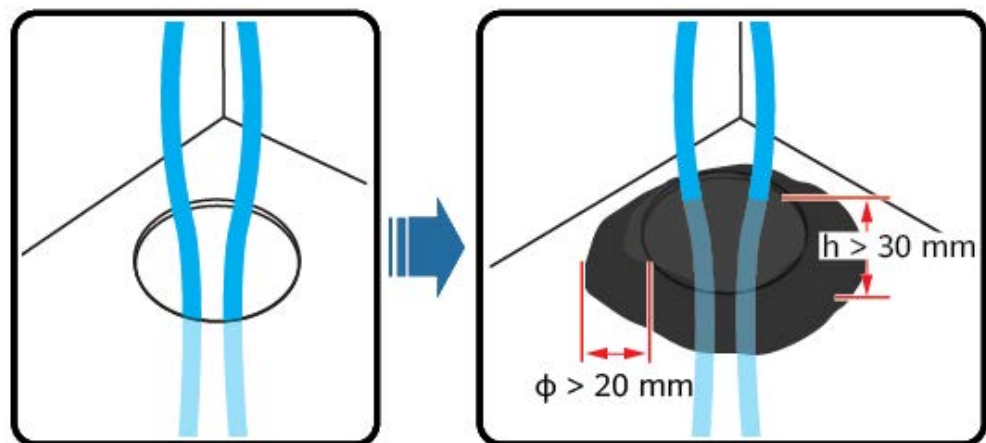

TN01H00006

- After installing the equipment, remove the packing materials such as cartons, foam, plastics, and cable ties from the equipment area.

1.4 Mechanical Safety

DANGER

When working at heights, wear a safety helmet and safety harness or waist belt and fasten it to a solid structure. Do not mount it on an insecure moveable object or metal object with sharp edges. Make sure that the hooks will not slide off.

 **WARNING**

Ensure that all necessary tools are ready and inspected by a professional organization. Do not use tools that have signs of scratches or fail to pass the inspection or whose inspection validity period has expired. Ensure that the tools are secure and not overloaded.

 **WARNING**

Before installing equipment in a cabinet, ensure that the cabinet is securely fastened with a balanced center of gravity. Otherwise, tipping or falling cabinets may cause bodily injury and equipment damage.

 **WARNING**

When pulling equipment out of a cabinet, be aware of unstable or heavy objects in the cabinet to prevent injury.

 **WARNING**

Do not drill holes into the equipment. Doing so may affect the sealing performance and electromagnetic containment of the equipment and damage components or cables inside. Metal shavings from drilling may short-circuit boards inside the equipment.

General Requirements

- Repaint any paint scratches caused during equipment transportation or installation in a timely manner. Equipment with scratches must not be exposed for an extended period of time.
- Do not perform operations such as arc welding and cutting on the equipment without evaluation by the Company.
- Do not install other devices on the top of the equipment without evaluation by the Company.
- When performing operations over the top of the equipment, take measures to protect the equipment against damage.
- Use correct tools and operate them in the correct way.

Moving Heavy Objects

- Be cautious to prevent injury when moving heavy objects.

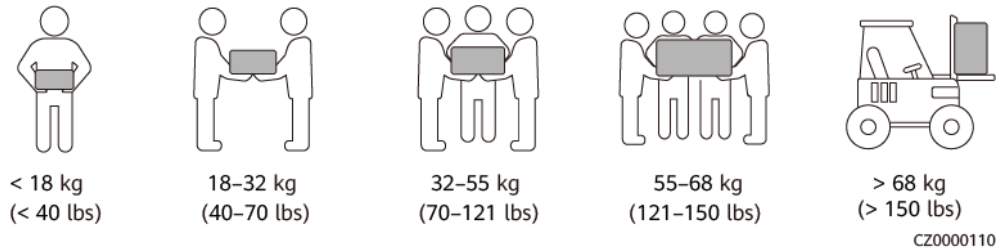

- If multiple persons need to move a heavy object together, determine the manpower and work division with consideration of height and other conditions to ensure that the weight is equally distributed.
- If two persons or more move a heavy object together, ensure that the object is lifted and landed simultaneously and moved at a uniform pace under the supervision of one person.
- Wear personal protective gears such as protective gloves and shoes when manually moving the equipment.
- To move an object by hand, approach to the object, squat down, and then lift the object gently and stably by the force of the legs instead of your back. Do not lift it suddenly or turn your body around.
- Move or lift the equipment by holding its handles or lower edges. Do not hold the handles of modules that are installed in the equipment.
- Do not quickly lift a heavy object above your waist. Place the object on a workbench that is half-waist high or any other appropriate place, adjust the positions of your palms, and then lift it.
- Move a heavy object stably with balanced force at an even and low speed. Put down the object stably and slowly to prevent any collision or drop from scratching the surface of the equipment or damaging the components and cables.
- When moving a heavy object, be aware of the workbench, slope, staircase, and slippery places. When moving a heavy object through a door, ensure that the door is wide enough to move the object and avoid bumping or injury.
- When transferring a heavy object, move your feet instead of turning your waist around. When lifting and transferring a heavy object, ensure that your feet point to the target direction of movement.
- When transporting the equipment using a pallet truck or forklift, ensure that the tynes are properly positioned so that the equipment does not topple. Before moving the equipment, secure it to the pallet truck or forklift using ropes. When moving the equipment, assign dedicated personnel to take care of it.
- Choose sea or roads in good conditions for transportation. Do not transport the equipment by railway or air. Avoid tilt or jolt during transportation.
- When moving and transporting an air conditioner, keep it upright and do not place it horizontally or upside down. If the package of the air conditioner is damaged or the tilt indicator on the package changes color, contact the Company's service engineers.

Working at Heights

- Any operations performed 2 m or higher above the ground shall be supervised properly.

- Only trained and qualified personnel are allowed to work at heights.
- Do not work at heights when steel pipes are wet or other risky situations exist. After the preceding conditions no longer exist, the safety owner and relevant technical personnel need to check the involved equipment. Operators can begin working only after safety is confirmed.
- Set a restricted area and prominent signs for working at heights to warn away irrelevant personnel.
- Set guard rails and warning signs at the edges and openings of the area involving working at heights to prevent falls.
- Do not pile up scaffolding, springboards, or other objects on the ground under the area involving working at heights. Do not allow people to stay or pass under the area involving working at heights.
- Carry operation machines and tools properly to prevent equipment damage or personal injury caused by falling objects.
- Personnel involving working at heights are not allowed to throw objects from the height to the ground, or vice versa. Objects shall be transported by slings, hanging baskets, aerial work platforms, or cranes.
- Do not perform operations on the upper and lower layers at the same time. If unavoidable, install a dedicated protective shelter between the upper and lower layers or take other protective measures. Do not pile up tools or materials on the upper layer.
- Dismantle the scaffolding from top down after finishing the job. Do not dismantle the upper and lower layers at the same time. When removing a part, ensure that other parts will not collapse.
- Ensure that personnel working at heights strictly comply with the safety regulations. The Company is not responsible for any accident caused by violation of the safety regulations on working at heights.
- Behave cautiously when working at heights. Do not rest at heights.

Using Ladders

- Use wooden or insulated ladders when you need to perform live-line working at heights.
- Platform ladders with protective rails are preferred. Do not use single ladders.
- Before using a ladder, check that it is intact and confirm its load bearing capacity. Do not overload it.
- Ensure that the ladder is securely positioned and held firm.



CZ00000107

- When climbing up the ladder, keep your body stable and your center of gravity between the side rails, and do not overreach to the sides.
- When a step ladder is used, ensure that the pull ropes are secured.

Hoisting

- Only trained and qualified personnel are allowed to perform hoisting operations.
- Install temporary warning signs or fences to isolate the hoisting area.
- Ensure that the foundation where hoisting is performed on meets the load-bearing requirements.
- Before hoisting objects, ensure that hoisting tools are firmly secured onto a fixed object or wall that meets the load-bearing requirements.
- During hoisting, do not stand or walk under the crane or the hoisted objects.
- Do not drag steel ropes and hoisting tools or bump the hoisted objects against hard objects during hoisting.
- Ensure that the angle between two hoisting ropes is no more than 90 degrees, as shown in the following figure.

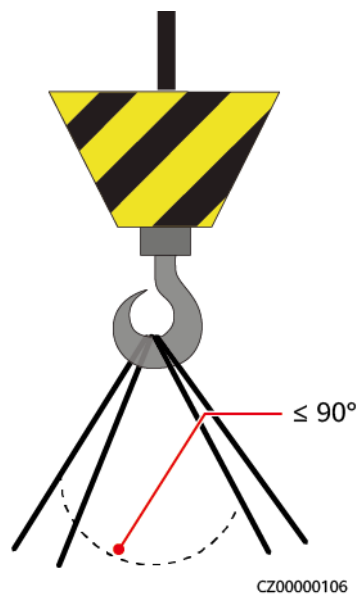

Drilling Holes

- Obtain consent from the customer and contractor before drilling holes.
- Wear protective equipment such as safety goggles and protective gloves when drilling holes.
- To avoid short circuits or other risks, do not drill holes into buried pipes or cables.
- When drilling holes, protect the equipment from shavings. After drilling, clean up any shavings.

1.5 Equipment Safety

1.5.1 ESS Safety

 **DANGER**

Do not open cabinet doors when the system is running.

 **DANGER**

If the ESS is faulty, do not stand within the opening range of the cabinet doors.

 **CAUTION**

Evacuate from the site immediately once the fire alarm horn/strobe is triggered.

NOTICE

Take protection and isolation measures for the ESS, such as installing fences, walls, and safety warning signs to prevent personal injury or property damage caused by unauthorized access during operations.

- When installing the ESS, comply with the fire separation distance or fire wall requirements specified in local standards, including but not limited to *GB 51048-2014 Design Code for Electrochemical Energy Storage Station* and *NFPA 855 Standard for the Installation of Stationary Energy Storage Systems*.
- Check the fire safety of the ESS regularly, at least once a month.
- When inspecting the system with power on, pay attention to the hazard warning signs on the equipment. Do not stand at the battery cabin doors.
- After power components of the ESS are replaced or cable connections are changed, you need to manually start cable connection detection and topology identification to prevent system malfunction.
- It is recommended that you prepare a camera to record the detailed processes of equipment installation, operation, and maintenance.

1.5.2 Battery Safety

 **DANGER**

Do not connect the positive and negative poles of a battery together. Otherwise, the battery may be short-circuited. Battery short circuits can generate high instantaneous current and releases a large amount of energy, which may cause battery leakage, smoke, flammable gas release, thermal runaway, fire, or explosion. To avoid battery short circuits, do not maintain batteries with power on.

 **DANGER**

Do not expose batteries at high temperatures or around heat sources, such as scorching sunlight, fire sources, transformers, and heaters. Battery overheating may cause leakage, smoke, flammable gas release, thermal runaway, fire, or explosion.

 **DANGER**

Protect batteries from mechanical vibration, falling, collision, punctures, and strong impact. Otherwise, the batteries may be damaged or catch fire.

 **DANGER**

To avoid leakage, smoke, flammable gas release, thermal runaway, fire, or explosion, do not disassemble, alter, or damage batteries, for example, insert foreign objects into batteries, squeeze batteries, or immerse batteries in water or other liquids.

 **DANGER**

Do not touch battery terminals with other metal objects, which may cause heat or electrolyte leakage.

 **DANGER**

There is a risk of fire or explosion if the model of the battery in use or used for replacement is incorrect. Use a battery of the model recommended by the manufacturer.

 **DANGER**

Battery electrolyte is toxic and volatile. Do not get contact with leaked liquids or inhale gases in the case of battery leakage or odor. In such cases, stay away from the battery and contact professionals immediately. Professionals must wear safety goggles, rubber gloves, gas masks, and protective clothing, power off the equipment, remove the battery, and contact technical engineers.

 **DANGER**

A battery is an enclosed system and will not release any gases under normal operations. If a battery is improperly treated, for example, burnt, needle-pricked, squeezed, struck by lightning, overcharged, or subject to other adverse conditions that may cause battery thermal runaway, the battery may be damaged or an abnormal chemical reaction may occur inside the battery, resulting in electrolyte leakage or production of gases such as CO and H₂. To prevent fire or device corrosion, ensure that flammable gas is properly exhausted.

 **DANGER**

The gas generated by a burning battery may irritate your eyes, skin, and throat. Take protective measures promptly.

 **WARNING**

Install batteries in a dry area. Do not install them under areas prone to water leakage, such as air conditioner vents, ventilation vents, feeder windows of the equipment room, or water pipes. Ensure that no liquid enters the equipment to prevent faults or short circuits.

 **WARNING**

Before installing and commissioning batteries, prepare fire fighting facilities, such as fire sand and carbon dioxide fire extinguishers, according to construction standards and regulations. Before putting into operation, ensure that fire fighting facilities that comply with local laws and regulations are installed.

 **WARNING**

Before unpacking, storage, and transportation, ensure that the packing cases are intact and the batteries are correctly placed according to the labels on the packing cases. Do not place a battery upside down or vertically, lay it on one side, or tilt it. Stack the batteries according to the stacking requirements on the packing cases. Ensure that the batteries do not fall or get damaged. Otherwise, they will need to be scrapped.

 **WARNING**

After unpacking batteries, place them in the required direction. Do not place a battery upside down or vertically, lay it on one side, tilt it, or stack it. Ensure that the batteries do not fall or get damaged. Otherwise, they will need to be scrapped.

 **WARNING**

Tighten the screws on copper bars or cables to the torque specified in this document. Periodically confirm whether the screws are tightened, check for rust, corrosion, or other foreign objects, and clean them up if any. Loose screw connections will result in excessive voltage drops and batteries may catch fire when the current is high.

 **WARNING**

After batteries are discharged, charge them in time to avoid damage due to overdischarge.

Statement

The Company shall not be liable for any battery damage, personal injury, death, property loss, and/or other consequences caused by the following reasons:

- Force majeure such as earthquakes, floods, volcanic eruptions, debris flows, lightning strikes, fires, wars, armed conflicts, typhoons, hurricanes, tornadoes, and other extreme weather conditions
- The battery warranty period has expired. You are advised not to use a battery whose warranty period has expired, as this poses safety risks.
- Actions that do not follow instructions in the user manual or direct advice from the Company, including but not limited to the following scenarios:
 - The onsite equipment operating environment or external power parameters do not meet the environment requirements for normal operation, for example, the actual operating temperature of batteries is too high or too low, or the power grid is unstable and experiences outages frequently.
 - Batteries are dropped or incorrectly operated or connected.
 - Batteries are overdischarged due to delayed acceptance or power-on after battery installation.
 - Battery running parameters are incorrectly set.
 - Different types of batteries, for example, batteries of different brands or rated capacities, are used together without prior approval from the Company.
 - Batteries are frequently overdischarged due to improper battery maintenance.
 - Battery use scenarios are changed without prior approval from the Company.
 - Battery maintenance is not performed according to the instructions in the user manual, for example, failing to check battery terminals regularly.
 - Batteries are not transported, stored, or charged according to the instructions in the user manual.

- Instructions from the Company are not followed during battery relocation or reinstallation.

General Requirements

NOTICE

To ensure battery safety and battery management accuracy, use batteries provided by the Company. The Company is not responsible for any faults of batteries not provided by it.

- Before installing, operating, and maintaining batteries, read the battery manufacturer's instructions and comply with their requirements. The safety precautions specified in this document are highly important and require special attention. For additional safety precautions, see the instructions provided by the battery manufacturer.
- Use batteries within the specified temperature range. When the ambient temperature of the batteries is lower than the allowed range, do not charge the batteries to prevent internal short circuits caused during low-temperature charging.
- Before unpacking batteries, check whether the packaging is intact. Do not use batteries with damaged packaging. If any damage is found, notify the carrier and manufacturer immediately.
- Install batteries within 24 hours after unpacking. If the batteries cannot be installed in time, put them in the original packaging and place them in a dry indoor environment without corrosive gases. Power on the ESS within 24 hours after installation. The process from unpacking batteries to powering on the system must be completed within 72 hours. During routine maintenance, ensure that the power-off time does not exceed 24 hours.
- Do not use a damaged battery (such as damage caused when a battery is dropped, bumped, bulged, or dented on the enclosure), because the damage may cause electrolyte leakage or flammable gas release. In the case of electrolyte leakage or structural deformation, contact the installer or professional O&M personnel immediately to remove or replace the battery. Do not store the damaged battery near other devices or flammable materials and keep it away from non-professionals.
- Before working on a battery, ensure that there is no irritant or scorched smell around the battery.
- When installing batteries, do not place installation tools, metal parts, or sundries on the batteries. After the installation is complete, clean up the objects on the batteries and the surrounding area.
- Do not install battery packs on rainy, snowy, or foggy days. Otherwise, the battery packs may be corroded by moisture or rain.
- If batteries are exposed to water accidentally, do not install them. Instead, transport the batteries to a safe isolation point and dispose of them in a timely manner.
- Before installing a battery pack, check that its enclosure is not deformed or damaged.

- Check whether the positive and negative battery terminals are grounded unexpectedly. If so, disconnect the battery terminals from the ground.
- Do not perform welding or grinding work around batteries to prevent fire caused by electric sparks or arcs.
- If batteries are left unused for a long period of time, store and charge them according to the battery requirements.
- Do not charge or discharge batteries by using a device that does not comply with local laws and regulations.
- Keep the battery loop disconnected during installation and maintenance.
- Monitor damaged batteries during storage for signs of smoke, flame, electrolyte leakage, or heat.
- If a battery is faulty, its surface temperature may be high. Do not touch the battery to avoid scalds.
- Do not stand on, lean on, or sit on the top of the equipment.
- In backup power scenarios, do not use the batteries for the following situations:
 - Medical devices substantially important to human life
 - Control equipment such as trains and elevators, as this may cause personal injury
 - Computer systems of social and public importance
 - Locations near medical devices
 - Other devices similar to those described above

Short-Circuit Protection

- When installing and maintaining batteries, wrap the exposed cable terminals on the batteries with insulation tape.
- Avoid foreign objects (such as conductive objects, screws, and liquids) from entering a battery, as this may cause short circuits.

Leakage Handling

NOTICE

Electrolyte leakage may damage the equipment. It will corrode metal parts and boards, and ultimately damage the boards.

Electrolyte is corrosive and can cause irritation and chemical burns. If you come into direct contact with the battery electrolyte, do as follows:

- Inhalation: Evacuate from contaminated areas, get fresh air immediately, and seek immediate medical attention.
- Eye contact: Immediately wash your eyes with water for at least 15 minutes, do not rub your eyes, and seek immediate medical attention.
- Skin contact: Wash the affected areas immediately with soap and water and seek immediate medical attention.

- Intake: Seek immediate medical attention.

Recycling

- Dispose of waste batteries in accordance with local laws and regulations. Do not dispose of batteries as household waste. Improper disposal of batteries may result in environmental pollution or an explosion.
- If a battery leaks or is damaged, contact technical support or a battery recycling company for disposal.
- If batteries are out of service life, contact a battery recycling company for disposal.
- Do not expose waste batteries to high temperatures or direct sunlight.
- Do not place waste batteries in environments with high humidity or corrosive substances.
- Do not use faulty batteries. Contact a battery recycling company to scrap them as soon as possible to avoid environmental pollution.

2 Product Description

2.1 Model Description

This document involves the following product model:

LUNA2000-97KWH-1H1

LUNA2000-129KWH-2H1

LUNA2000-161KWH-2H1

LUNA2000-200KWH-2H1

Figure 2-1 Model number (example)

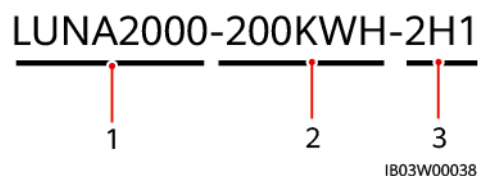

Table 2-1 Model number description

No.	Meaning	Description
1	Product family name	LUNA2000: Smart String ESS
2	Capacity level	200KWH: nominal energy of 193.5 kWh 161KWH: nominal energy of 161.3 kWh 129KWH: nominal energy of 129.0 kWh 97KWH: nominal energy of 96.8 kWh

No.	Meaning	Description
3	Backup power	200KWH-2H1: Applies to scenarios where the backup duration is greater than or equal to 2 hours. 161KWH-2H1: Applies to scenarios where the backup duration is greater than or equal to 1.5 hours. 129KWH-2H1: Applies to scenarios where the backup duration is greater than or equal to 1.25 hours. 97KWH-1H1: Applies to scenarios where the backup duration is greater than or equal to 1 hour.

2.2 Product Description

The ESS consists of a power control module and lithium battery modules. It stores and releases electricity controlled by the Smart Rack Controller (also referred to as rack controller). The input and output ports of the ESS are high-voltage direct current (HVDC) ports.

- Battery charge: The Smart Power Control System (also referred to as Smart PCS) is connected to the rack controller and sends commands to charge batteries.
- Battery discharge: When the grid power is insufficient for the loads, the system controls the batteries to supply power to the loads through the Smart PCS.

The ESS supports the antitheft function. This function is supported in LUNA2000B V100R023C00SPC120 and later versions.

The ESS supports the function of insulation resistance detection to detect the insulation status of the ESS. When an insulation fault occurs, the ESS reports an alarm and isolates the fault. This function is supported in LUNA2000B V100R023C00SPC120 and later versions.

2.3 Appearance

NOTE

This document uses the 200 kWh model as an example. The actual structure of a model may vary.

Figure 2-2 Appearance and dimensions

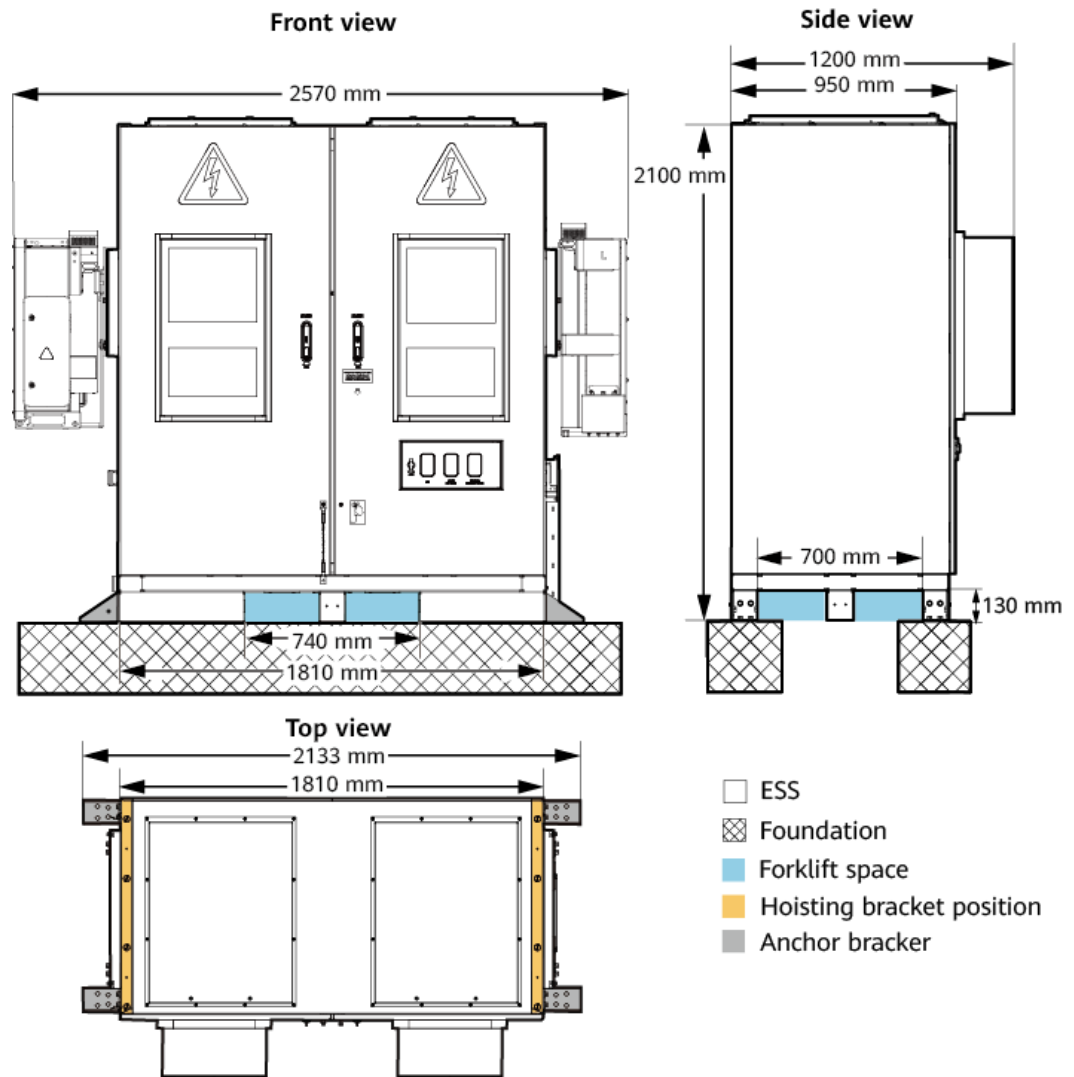

IB03W00026

NOTE

The site foundation must be designed by professional technical personnel such as those from a design institute. The technical personnel can refer to the foundation drawings of the Company. Contact the product manager of the Company to obtain the drawings.

2.4 Components

Figure 2-3 Components (doors closed)

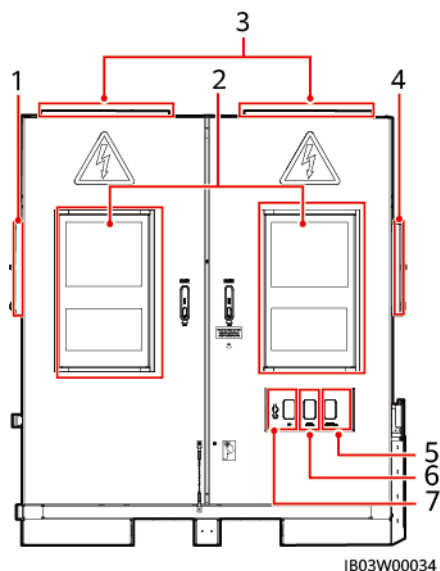

- | | | |
|--|---------------------------|-----------------------------|
| (1) Installation position of the Smart PCS | (2) Air conditioners | (3) Pressure relief windows |
| (4) Installation position of the rack controller | (5) Emergency stop switch | (6) Fire alarm horn/strobe |
| (7) USB port | - | - |

Table 2-2 Component configuration (1)

No.	Item	Maximum Quantity Configured for an ESS	Description
1	Installation position of the Smart PCS	1	Where the Smart PCS is installed.
2	Air conditioner	2	Air conditioners on the ESS cabinet door.
3	Pressure relief window	2	If an explosion occurs inside the equipment, the windows are open to release pressure.
4	Installation position of the rack controller	1	Where the rack controller is installed.

No.	Item	Maximum Quantity Configured for an ESS	Description
5	Emergency stop switch	1	Used for emergency stop of the rack controller.
6	Fire alarm/horn strobe	1	Generates alarms for internal devices when abnormal temperature or smoke occurs.
7	USB	1	Where a smart USB-WLAN adapter (USB-Adapter2000-C) is installed for local maintenance.

Figure 2-4 Components (doors opened)

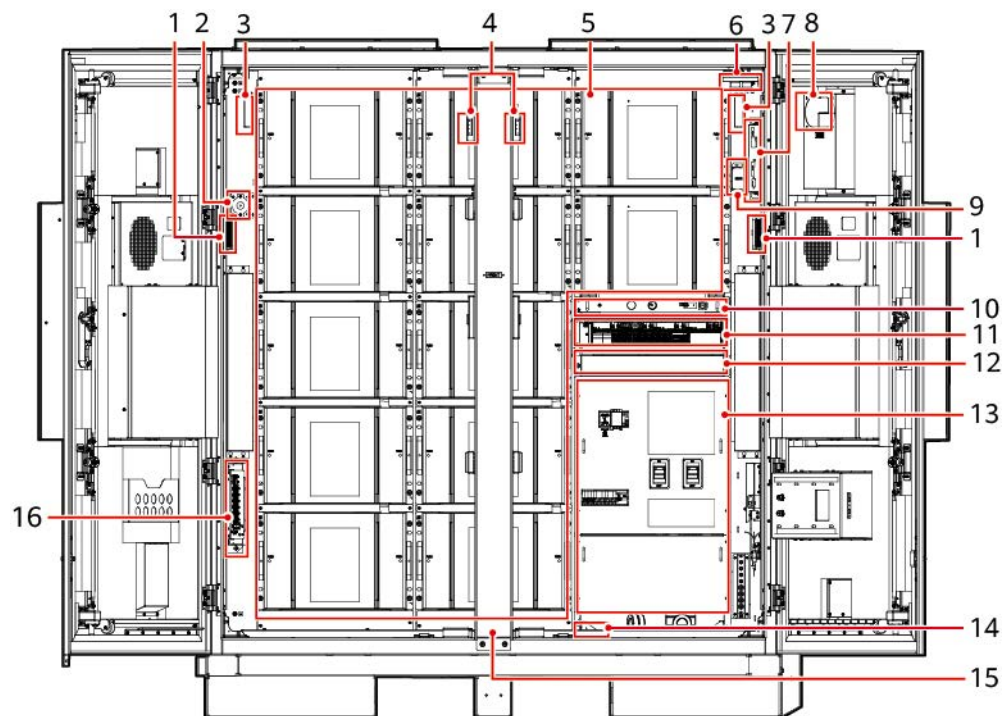

IB03W00035

- | | | |
|-------------------------|--|--------------------|
| (1) Lights | (2) Black start button | (3) CO sensors |
| (4) Door status sensors | (5) Installation position of battery packs | (6) Smoke detector |
| (7) Exhaust controller | (8) Exhaust module | (9) T/H sensor |

- (10) Installation position of the rack mounted fire extinguishing system (11) Embedded power subrack (12) Central Monitoring Unit (CMU)
- (13) Power distribution area (14) Water sensor (15) Adjustable column
- (16) I/O expansion board - -

Table 2-3 Component configuration (2)

No.	Item	Maximum Quantity Configured for an ESS	Description
1	Light	2	Used for lighting inside the cabinet.
2	Black start button	1	Triggers the ESS black start.
3	CO sensor	2	Checks the concentration of CO in combustible gases.
4	Door status sensor	2	Monitors the door opening and closing status.
5	Battery pack	12	A battery pack is a combination of batteries connected in series and output through a pair of positive and negative terminals. It contains a battery management module. The battery management module consists of the battery management unit (BMU), battery optimization module, and module fan.
6	Smoke detector	1	Photoelectric smoke detector, used for smoke detection.
7	Exhaust controller	1	Works with the CO sensor and exhaust fan to control air exhaust.
8	Exhaust module	1	Exhausts combustible gases from the cabinet.
9	T/H sensor	1	Measures the real-time ambient temperature and humidity in the cabinet.
10	Rack mounted fire extinguishing system	1	Used for fire alarm and automatic fire extinguishing control.
11	Embedded power subrack	1	Provides installation positions for components.

No.	Item	Maximum Quantity Configured for an ESS	Description
	Installation position of the PSU	5	Where the PSU is installed. The PSU converts AC input power into stable DC power.
	SMU11B	1	Collects PSU information and controls PSU output.
12	CMU	1	Converges interfaces, converts protocols, collects and stores data, centrally monitors and maintains devices in the ESS.
13	Power distribution area	-	For details, see Figure 2-5 .
14	Water sensor	1	Detects water based on the resistance change between both electrodes.
15	Adjustable column	1	Used to support the installation of the cabinet door.
16	I/O expansion board	1	Controls and monitors the door status sensor, sensors, and air conditioners in the ESS, connects cables to the fire suppression system, and black starts the system.

Figure 2-5 Components in the power distribution area

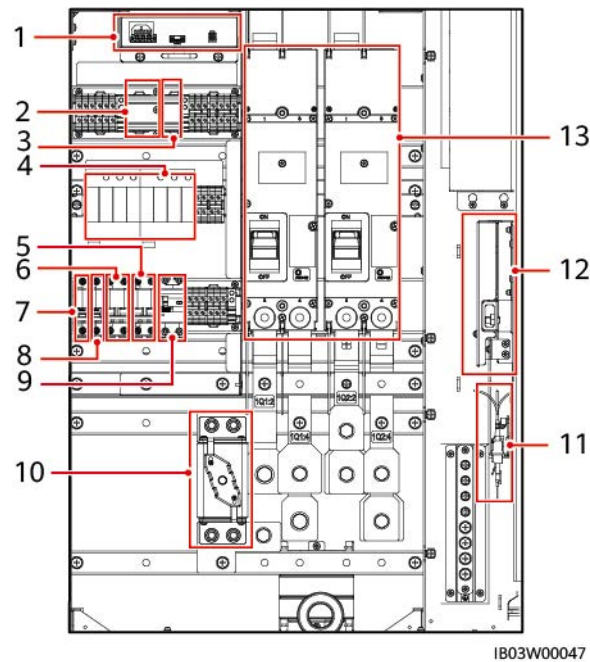

- | | | |
|--|--|---|
| (1) 12 V adapter (1TB1) | (2) Installation position of the 220 V maintenance socket (1XD1) | (3) Installation position of the Smart Power Sensor |
| (4) AC surge protective devices (SPDs) (1FA1 and 1FA2) | (5) UPS switch (5FCB) | (6) AC main switch (1FCB) |
| (7) 12 V adapter switch (1FCB1) | (8) PSU switch (1FCB2) | (9) 220 V maintenance socket switch (1FB1) |
| (10) Fuse (1F1) ^[1] | (11) Fiber adapter | (12) Fiber management tray |
| (13) DC switches (1Q1 and 1Q2) | - | - |

Note [1]: The 97 kWh, 129 kWh, and 161 kWh models have two fuses.

Table 2-4 Component configuration (3)

No.	Item	Maximum Quantity Configured for an ESS	Description
1	12 V adapter	1	Supplies power to components such as the CMU, SmartModule, I/O expansion board, and rack mounted fire extinguishing system.
2	(Optional) 220 V maintenance socket	1	Used to obtain power during maintenance.
3	(Optional) Smart Power Sensor	1	Measures the voltage and current of the 220 V AC auxiliary power supply.
4	AC SPD	2	Provides AC surge protection.
5	UPS switch	1	Switch of the UPS.
6	AC main switch	1	Main switch for AC power distribution.
7	12 V adapter switch	1	Switch of the 12 V adapter.
8	PSU switch	1	Switch of the PSU.
9	220 V maintenance socket switch	1	Switch of the maintenance socket.
10	Fuse	1	Provides short-circuit protection.
11	Fiber adapter	1	Used to connect optical fibers.
12	Fiber management tray	1	Holds optical fibers.
13	DC switch	2	Used to protect against short circuits and disconnect the DC bus.

2.4.1 Power Supply and Distribution System

Figure 2-6 Position of the power supply and distribution system

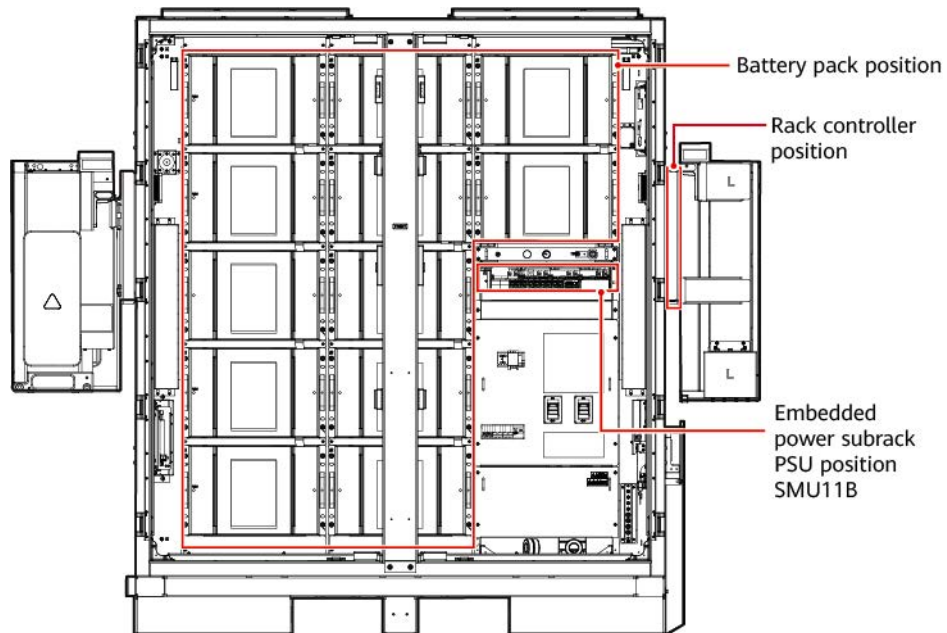

IB03W00041

2.4.1.1 Battery Pack

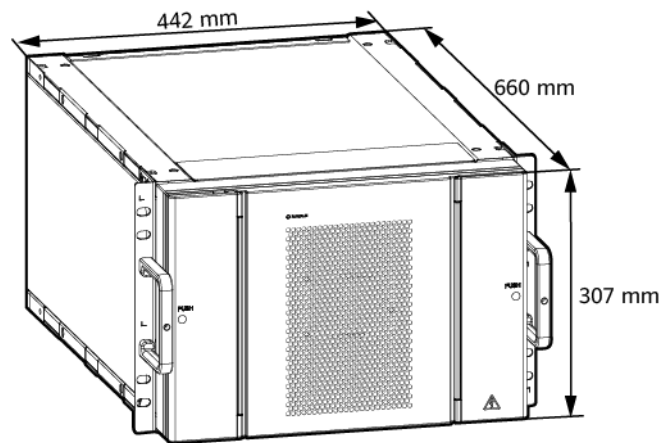

IB04H00010

Table 2-5 Battery pack technical specifications

Technical Specifications	Battery Pack (ESM51320AS1)	Battery Pack (ESM57280AS1)	Battery Pack (ESM57280AS1)
Cell capacity	3.2 V/320 Ah	3.2 V/280 Ah	3.2 V/280 Ah
Cell material	Lithium iron phosphate	Lithium iron phosphate	Lithium iron phosphate

Technical Specifications	Battery Pack (ESM51320AS1)	Battery Pack (ESM57280AS1)	Battery Pack (ESM57280AS1)
Combination mode	16S 1P	18S 1P	18S 1P
Rated voltage	51.2 V	57.6 V	57.6 V
Charge and discharge rate	≤ 1C	≤ 1C	≤ 0.5C
Nominal capacity	16.38 kWh	16.13 kWh	16.13 kWh
Weight	≤ 140 kg	≤ 140 kg	≤ 140 kg
Dimensions (H x W x D)	307 mm x 442 mm x 660 mm	307 mm x 442 mm x 660 mm	307 mm x 442 mm x 660 mm
Cooling mode	Air cooling	Air cooling	Air cooling
IP rating	IP20	IP20	IP20
Storage temperature	0°C to 40°C	0°C to 40°C	0°C to 40°C
Transportation temperature	-40°C to +60°C	-40°C to +60°C	-40°C to +60°C
Balancing mode	Passive cell balancing	Passive cell balancing	Passive cell balancing
Communications port	CAN 2.0	CAN 2.0	CAN 2.0

2.4.1.2 Smart Rack Controller

Figure 2-7 Rack controller

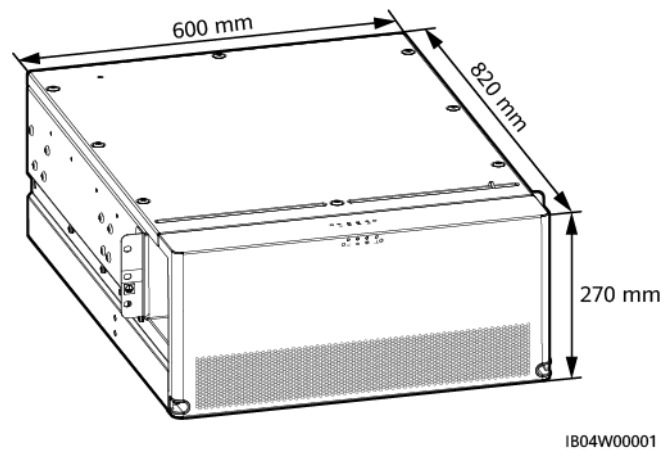

IB04W00001

Table 2-6 Efficiency

Technical Specifications	Rack Controller
Maximum efficiency	≥ 98.5%
Full-load efficiency	≥ 98.5%

Table 2-7 Battery side

Technical Specifications	Rack Controller
Number of battery racks	1
Rated operating voltage	614.4 V@320 Ah cell 691.2 V@280 Ah cell
Rated operating current of a single battery rack	80 A
Maximum operating current of a single battery rack	95 A
Operating voltage	40–1050 V
Constant power voltage range	655–760 V
Constant current voltage range	560–655 V
Minimum startup voltage	350 V
Rated power of a single battery rack	52 kW
Rated power of a rack controller	104 kW

Technical Specifications	Rack Controller
Operating current of a single battery rack	80 A

Table 2-8 Bus side

Technical Specifications	Rack Controller
Number of battery racks connected to the bus	2
Maximum DC voltage	1100 V
Rated operating voltage	665 V
Full-load voltage range	595–810 V
Rated operating current of a single battery rack	76.3 A
Maximum operating current of a single battery rack	92 A

Table 2-9 Protection

Technical Specifications	Rack Controller
Reverse connection protection	Supported
Surge protection	Supported (bus side)
Insulation resistance detection	Supported
Overtemperature protection	Supported
Overcurrent protection on the battery side	Supported
Short circuit protection on the battery side	Supported
Short circuit protection on the bus side	Supported

Table 2-10 General specifications

Technical Specifications	Rack Controller
Parallel mode	Two rack controllers connected in parallel on the battery side and two on the bus side

Technical Specifications	Rack Controller
Power overload	Long-term running at 1.1 times the rated power
Overvoltage category	Bus side DC II
Dimensions (H x W x D)	270 mm x 600 mm x 820 mm
Weight	≤ 90 kg
DC surge protection on the bus side	Type II
Operating temperature range	-30°C to +60°C (The rack controller can be started at -40°C.)
Operating humidity range	0%~100%
Storage temperature	-40°C to +70°C
Storage humidity	5%~95% RH
Cooling mode	Smart air cooling
IP rating	IP66
Maximum operating altitude	4000 m
Input and output terminals	OT terminals
Power response time (from no load to full load)	< 30 ms
Standby power consumption	7 W in shutdown mode, 48 V external power supply 30 W in shutdown mode, battery power supply, contactor not closed 70 W in standby mode, battery power supply, contactor closed
Environmental protection requirement	RoHS 6
Communications port	CAN, RS485, FE

2.4.1.3 Embedded Power Subrack

Figure 2-8 Appearance

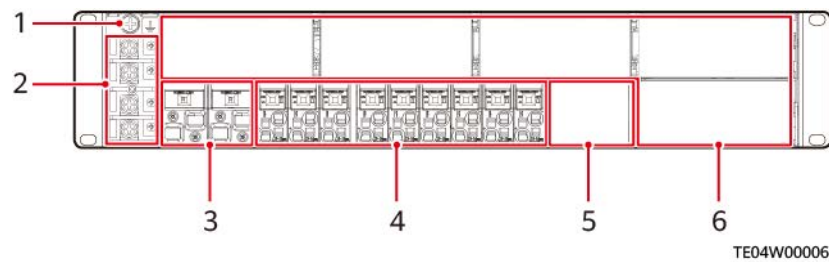

- | | | |
|-------------------|--------------------------------|--------------------------------|
| (1) Ground screw | (2) Input terminals | (3) Battery switches |
| (4) Load switches | (5) Monitoring module (SMU11B) | (6) PSU installation positions |

2.4.1.4 Monitoring Module (SMU11B)

Figure 2-9 SMU11B

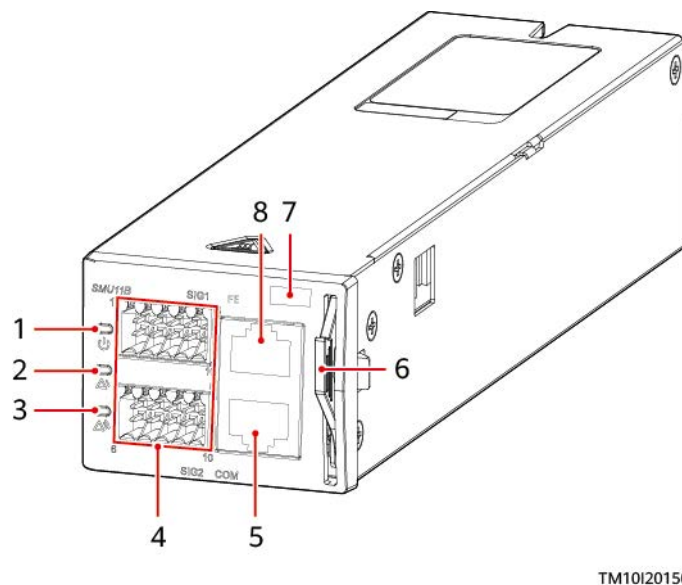

- | | | |
|------------------------|---------------------------|---------------------------|
| (1) Running indicator | (2) Minor alarm indicator | (3) Major alarm indicator |
| (4) Wiring terminals | (5) COM port | (6) Handle |
| (7) Position of the SN | (8) FE port | - |

Table 2-11 Indicator description

Indicator	Color	Status	Description
Running indicator	Green	Off	The SMU is faulty or has no power input.

Indicator	Color	Status	Description
		Blinking slowly (0.5 Hz)	The SMU is running properly and communicating with the host properly.
		Blinking fast (4 Hz)	The SMU is running properly but fails to communicate with the host.
Minor alarm indicator	Yellow	Off	No minor alarm or warning is generated.
		Steady on	A minor alarm or warning is generated.
Major alarm indicator	Red	Off	No critical or major alarm is generated.
		Steady on	A critical or major alarm is generated.

2.4.1.5 PSU

The PSU (R4830G) converts AC input power into stable DC power.

Appearance

Figure 2-10 PSU

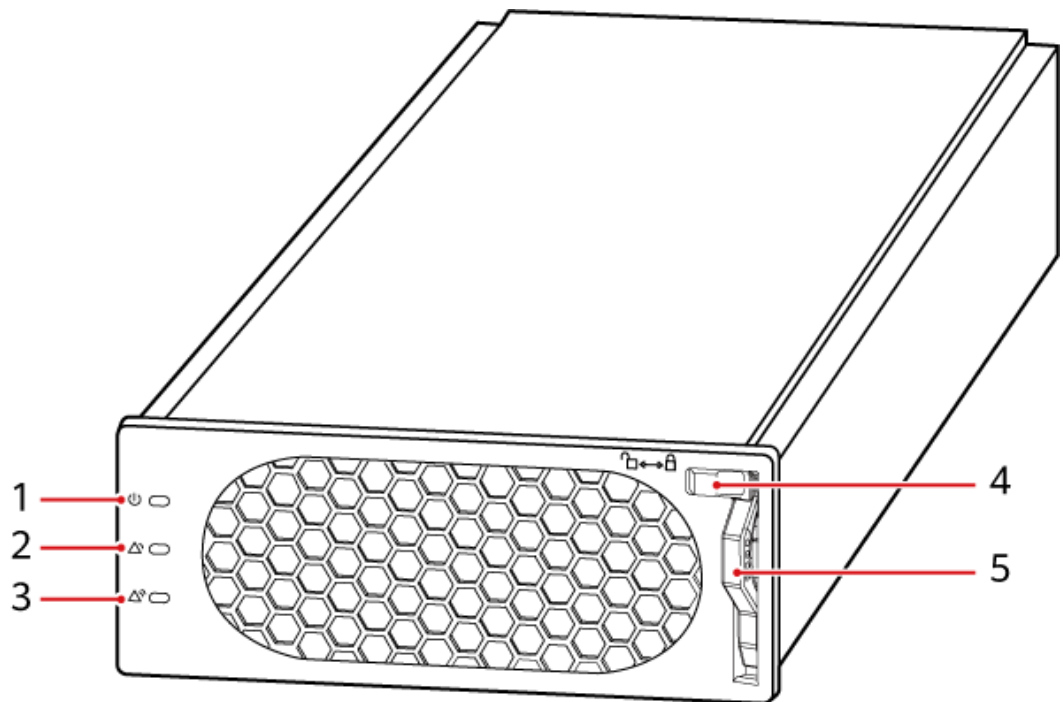

PR04WC0008

- | | | |
|---------------------|---------------------|---------------------|
| (1) Power indicator | (2) Alarm indicator | (3) Fault indicator |
| (4) Locking latch | (5) Handle | - |

Indicators

Table 2-12 Indicator description

Indicator	Color	Status	Description
Power indicator	Green	Steady on	The PSU has AC input.
		Off	The PSU has no AC input.
		Blinking (0.5 Hz)	The PSU is damaged.
		Blinking (4 Hz)	Querying is in progress.
Alarm indicator	Yellow	Off	The PSU is loading an application program.
			The PSU has no protection alarm.

Indicator	Color	Status	Description
		Steady on	<ul style="list-style-type: none"> A warning is generated due to ambient overtemperature. A shutdown protection alarm is generated due to ambient overtemperature or undertemperature.
			AC input overvoltage or undervoltage protection is triggered.
		The PSU is hibernating.	
		Blinking (0.5 Hz)	The communication between the PSU and an external device is interrupted.
Fault indicator	Red	Off	The PSU is normal.
		Steady on	The module locks out due to output overvoltage.
			The PSU has no output due to internal faults.

2.4.2 Monitoring System

Figure 2-11 Position of the monitoring system

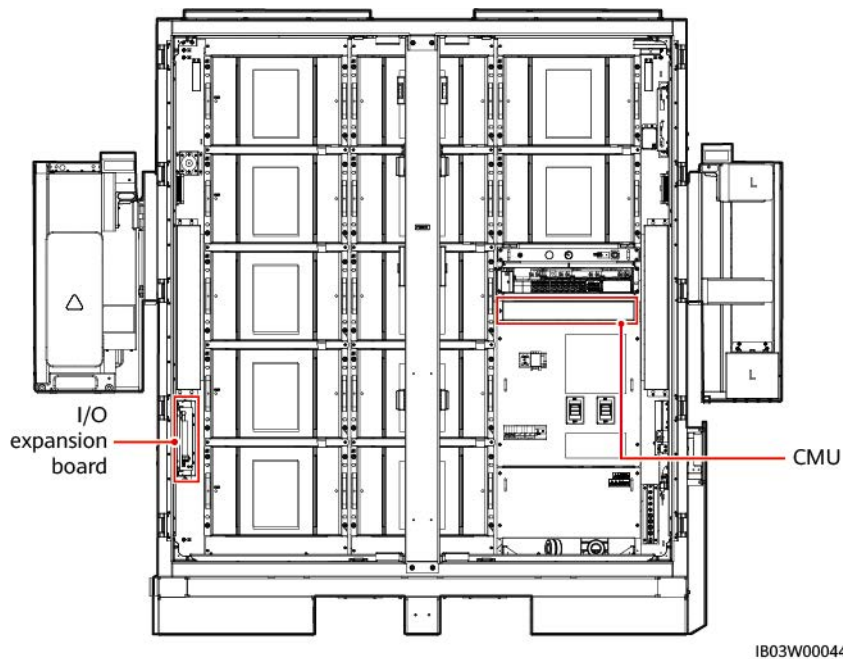

2.4.2.1 Central Monitoring Unit (CMU)

Appearance

Figure 2-12 Appearance

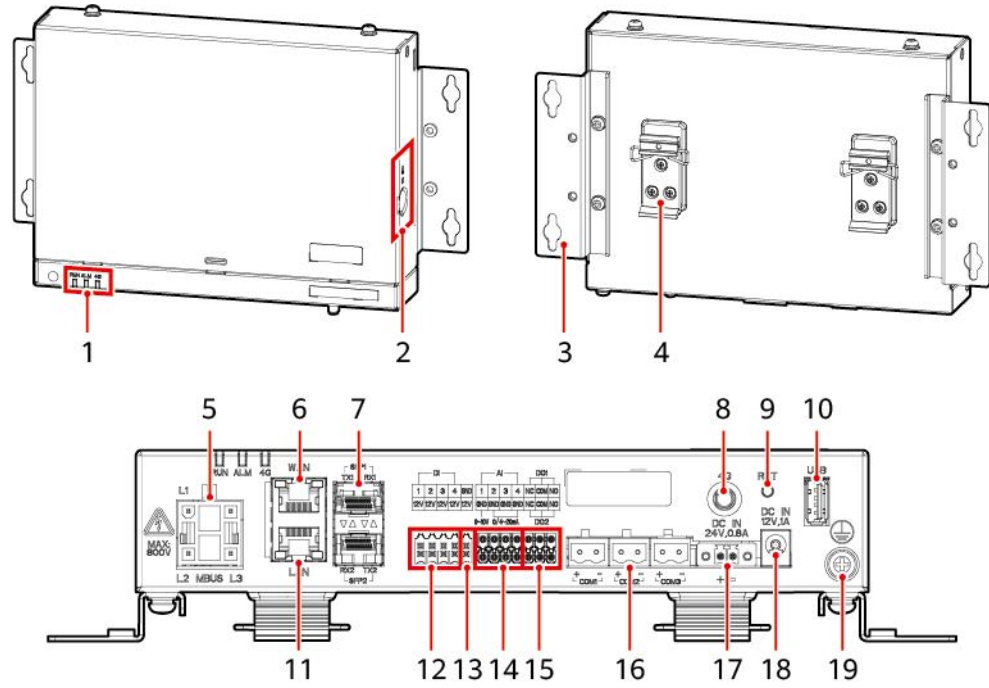



IL04W00003

- | | | |
|--------------------------------|--------------------------------|----------------------------|
| (1) LED indicators | (2) SIM card slot | (3) Mounting ear |
| (4) Guide rail clamp | (5) MBUS port (reserved) | (6) GE port (WAN) |
| (7) SFP port | (8) 4G antenna port (reserved) | (9) RST button |
| (10) USB port | (11) GE port (LAN) | (12) DI ports |
| (13) 12 V output power port | (14) AI ports | (15) DO ports |
| (16) COM ports | (17) 24 V input power port | (18) 12 V input power port |
| (19) Protective earthing point | - | - |

Indicators

Table 2-13 Indicator description

Indicator	Status	Description	
Running indicator (RUN) 	Green off	Not powered on	
	Blinking green slowly (on for 1s and then off for 1s)	The communication with the management system is normal.	
	Blinking green fast (on for 0.125s and then off for 0.125s)	The communication with the management system is interrupted.	
Alarm/Maintenance indicator (ALM) 	Alarm status	Red off	No system alarm is generated.
		Blinking red slowly (on for 1s and then off for 4s)	The system raises a warning alarm.
		Blinking red fast (on for 0.5s and then off for 0.5s)	The system raises a minor alarm.
		Steady red	The system raises a major alarm.
	Maintenance status	Green off	No local maintenance is in progress.
		Blinking green slowly (on for 1s and then off for 1s)	Local maintenance is in progress.
		Blinking green fast (on for 0.125s and then off for 0.125s)	Local maintenance fails or the connection to the app is to be set up.
		Steady green	Local maintenance succeeded.

2.4.2.2 I/O Expansion Board

The I/O expansion board controls and monitors the door status sensor, sensors, and air conditioners in the ESS, connects cables to the fire suppression system, and black starts the system.

Technical Specifications	I/O Expansion Board
Model	ENF1DETC
Operating voltage	220 V AC/12 V DC/24 V DC
Operating current	≤ 1 A
Operating temperature	-30°C to +55°C
Humidity	≤ 95% RH (non-condensing)
Dimensions (H x W x D)	113.7 mm x 251 mm x 54.5 mm

2.4.3 Environment Control System

Figure 2-13 Position of the environment control system

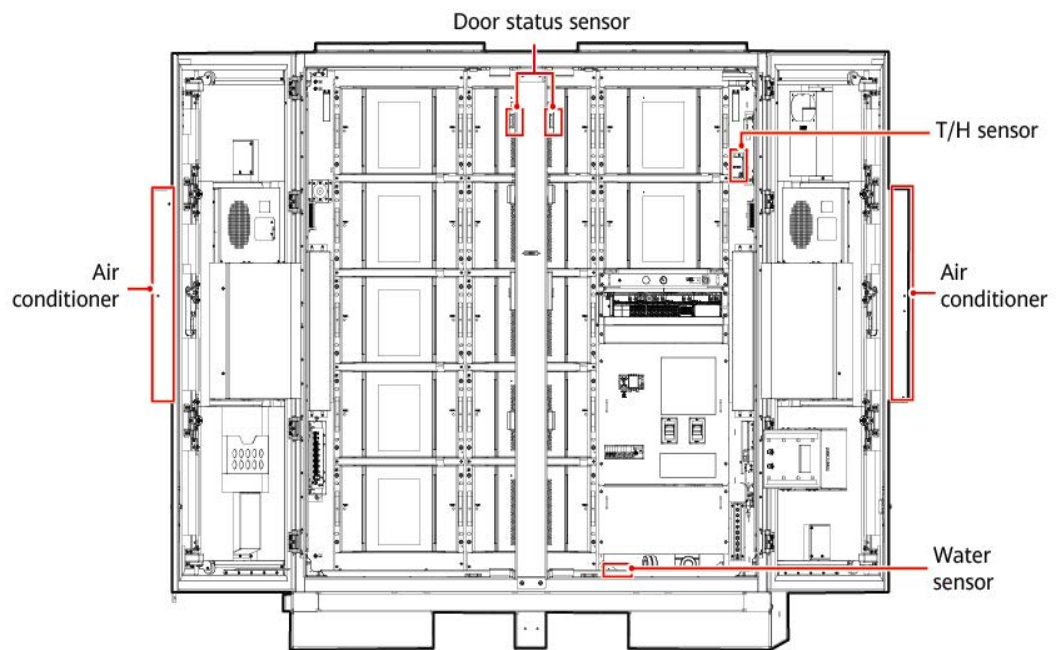

IB03W00042

2.4.3.1 Air Conditioner

Figure 2-14 Appearance

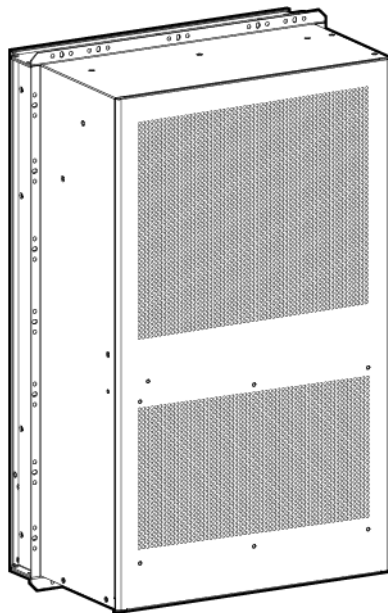

IB04W00015

Technical Specifications	Air Conditioner
Power specifications	Operating voltage range: -42 V DC to -57 V DC; rated voltage: -48 V DC
Temperature control range	15-35°C
Temperature control precision	±1°C
Sensible cooling capacity (L25/45)	2000 W
Rated power	1050 W
Maximum power	1200 W
Air volume	700 m ³ /h
Heating capacity	1200 W
Dimensions (H x W x D)	746 mm x 446 mm x 300 mm
Weight	38.4 kg
IP rating	IP55 (between the internal air circulation and the external air circulation)
Operating temperature range	-30°C to +55°C

Technical Specifications	Air Conditioner
Refrigerant	R134a
Variable-frequency or not	Variable-frequency air conditioner

2.4.3.2 T/H Sensor

Figure 2-15 Appearance

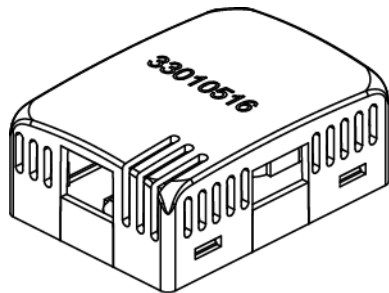

IB04W00024

NOTE

- The appearance of the T/H sensor delivered onsite may vary.
- The T/H sensor belongs to the environment control system and fire suppression system in the ESS.

Technical Specifications	T/H Sensor
Temperature measurement range	-20°C to +80°C
Measurement range and precision	Temperature: -20°C to +80°C, error ≤ ±1°C Humidity: 0% RH to 100% RH, error ≤ ±8% RH
Operating temperature	-20°C to +80°C
Operating voltage	9-16 V DC
Storage temperature	-40°C to +80°C
Signal output	Two RJ45 ports, bidirectional cascading

The T/H sensor uses an RJ45 connector.

Figure 2-16 Pins of an RJ45 connector
RJ45 female connector

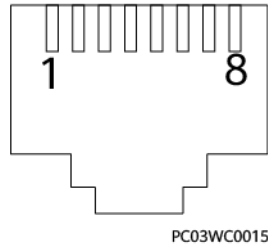
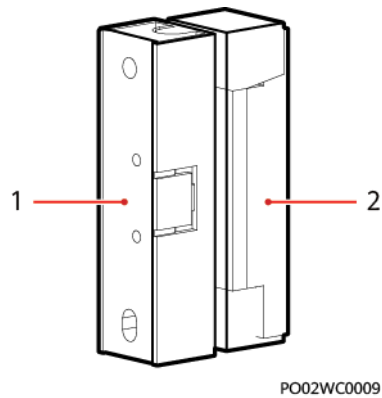

Table 2-14 Pin definitions of an RJ45 connector

Pin	Description
Pin 1 or pin 4	A
Pin 2 or pin 5	B
Pin 3	V+
Pin 6	Reserved
Pin 7	Reserved
Pin 8	V-

2.4.3.3 Door Status Sensor

Figure 2-17 Appearance



(1) Switch

(2) Magnet

Technical Specifications	Door Status Sensor
Connection method	Wiring terminals
Rated current	500 mA

Technical Specifications	Door Status Sensor
Startup distance	25–45 mm
Rated Power	10 W
Securing method	Screw
Hole spacing	40 mm±0.8 mm
Switch voltage	100 V DC (Max)
Contact withstand voltage	150 V DC (Max)
Impedance	0.3 Ω
Switch status	Steady on
Outer material	White acrylonitrile butadiene styrene (ABS) engineering plastic

2.4.3.4 Electrode Water Sensor

The water sensor detects water based on the resistance change between both electrodes.

When the electrodes detect water, they are short-circuited and the CMU reports an alarm.

Figure 2-18 Appearance

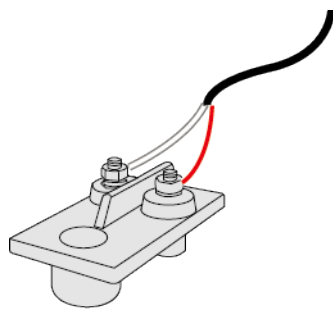

PO01WC0769

Technical Specifications	Electrode Water Sensor
Operating temperature	-40°C to +80°C
Storage temperature	-40°C to +80°C

2.4.4 Fire Suppression System

Figure 2-19 Position of the fire suppression system

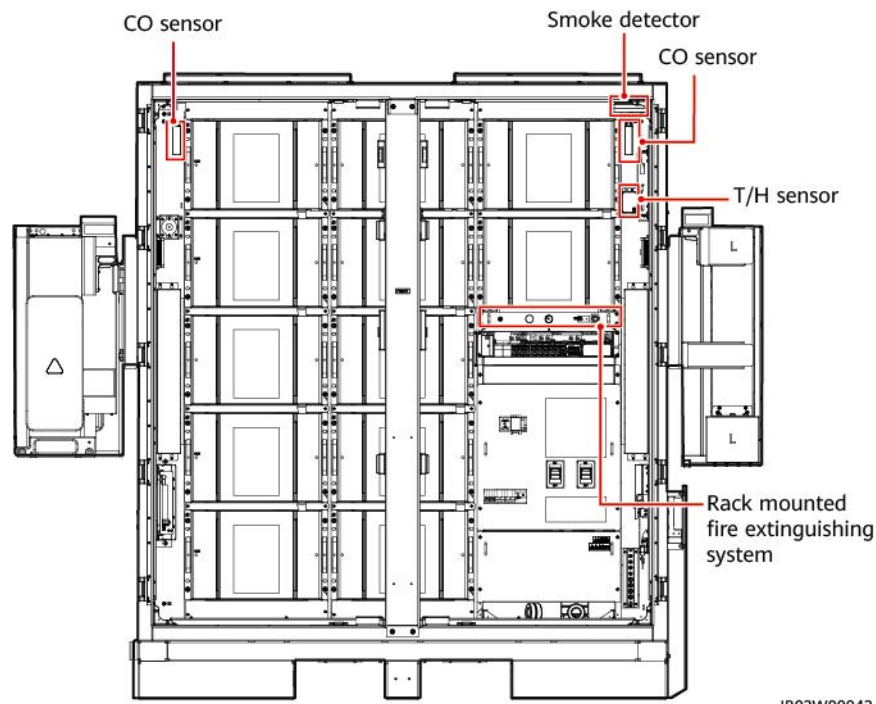

2.4.4.1 Rack Mounted Fire Extinguishing System

1. The rack mounted fire extinguishing system is pre-integrated in the cabinet.
2. The extinguishant is perfluorohexanone which features high insulation, environment friendly, and quick fire extinguishing and cooling.

Working Principles

The rack mounted fire extinguishing system adopts the thermo bulb and electric startup mode.

- When the temperature inside the cabinet is higher than the temperature of the thermo bulb for a certain period of time, the thermo bulb breaks to start the rack mounted fire extinguishing system.
- When the external fire suppression system detects a fire, it triggers the electric start signal of the rack mounted fire suppression system and opens the storage device of the extinguishant. The extinguishant is released through the nozzle to cool down and put out the fire.

NOTE

- The thermo bulb can also work normally during electric startup.
- When a fire occurs, the thermo bulb can start the rack mounted fire extinguishing system even if the electric startup mode fails. This ensures that the rack mounted fire extinguishing system can be started reliably.

Figure 2-20 Front

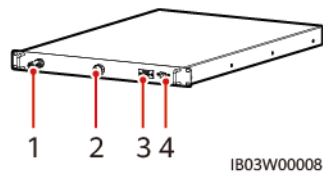
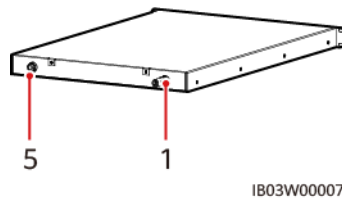

Figure 2-21 Rear



- (1) Thermo bulb (2) Pressure gauge (3) Wiring port for electric startup (4) Signal feedback (5) Extinguishant release nozzle assembly

Table 2-15 Technical specifications

Technical Specifications		Rack Mounted Fire Extinguishing System
Storage pressure (at 20°C)		1.6 MPa±0.2 MPa
Startup mode (thermo bulb)		Startup at a constant temperature: 79°C±3°C
Startup mode (electric startup)		External 12 V power, started by the solenoid valve
Alarming mode		Dry contact signal feedback
Operating environment	Safe operating temperature	-30°C to +55°C
	Transportation temperature	-40°C to +60°C
	Storage temperature	-40°C to +60°C
	Relative humidity	≤ 97% RH (40°C, non-condensing)
Dimensions		≤ 1 U (height) x 700 mm (depth) x 482 mm±1 mm (width)

2.4.4.2 T/H Sensor

Figure 2-22 Appearance

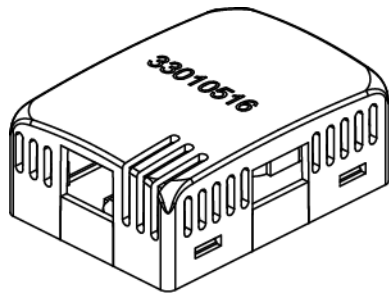

IB04W00024

NOTE

- The appearance of the T/H sensor delivered onsite may vary.
- The T/H sensor belongs to the environment control system and fire suppression system in the ESS.

Technical Specifications	T/H Sensor
Temperature measurement range	-20°C to +80°C
Measurement range and precision	Temperature: -20°C to +80°C, error ≤ ±1°C Humidity: 0% RH to 100% RH, error ≤ ±8% RH
Operating temperature	-20°C to +80°C
Operating voltage	9-16 V DC
Storage temperature	-40°C to +80°C
Signal output	Two RJ45 ports, bidirectional cascading

The T/H sensor uses an RJ45 connector.

Figure 2-23 Pins of an RJ45 connector
RJ45 female connector

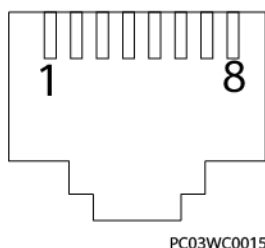

PC03WC0015

Table 2-16 Pin definitions of an RJ45 connector

Pin	Description
Pin 1 or pin 4	A
Pin 2 or pin 5	B
Pin 3	V+
Pin 6	Reserved
Pin 7	Reserved
Pin 8	V-

2.4.4.3 CO Sensor

Figure 2-24 Appearance

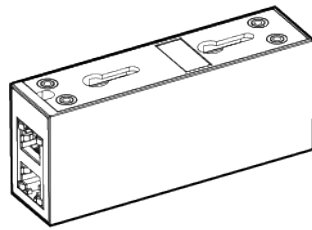

Technical Specifications	CO Sensor
Dimensions (H x W x D)	40 mm x 97 mm x 25 mm
Operating voltage	8–30 V DC
Stability	≤ ±3% FS/year
Precision	≤ ±10% FS
Power consumption	0.12 W
Output signal	RS485
Operating temperature	–25°C to +55°C
Humidity	5%–95% RH (non-condensing)
Resolution	≤ 30 ppm
Response time	≤ 60s
Cabling mode	RJ45 network port
Installation mode	Gourd-shaped mounting hole/nut/magnet

Figure 2-25 Pins of an RJ45 connector
RJ45 female connector

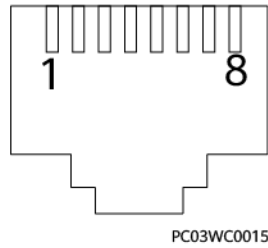

Table 2-17 Pin definitions of an RJ45 connector

Pin	Description
Pin 1 or pin 4	A
Pin 2 or pin 5	B
Pin 3	V+
Pin 6	Reserved
Pin 7	Reserved
Pin 8	V-

2.4.4.4 Smoke Detector

The smoke detector can detect the smoke concentration in the environment.

Figure 2-26 Appearance

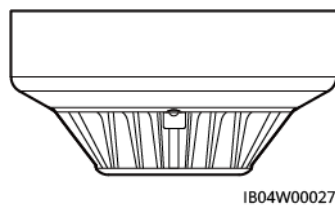

Table 2-18 Indicator description

Name	Color	Status	Description
Indicator	Red	Steady on	The detector enters the alarm state.
		Blinking	The detector enters the monitoring state.

Table 2-19 Technical specifications

Technical Specifications	Smoke Detector
Operating voltage	12 V (9–16 V DC)
Quiescent current	< 8 mA
Alarm current	< 35 mA
Output mode	Relay output
Polarity	None
Output contact capacity	3 A/120 V AC or 3 A/24 V AC
Operating temperature	–20°C to +60°C
Ambient humidity	< 95% RH (non-condensing)

2.4.5 Exhaust System

Figure 2-27 Position of the exhaust system

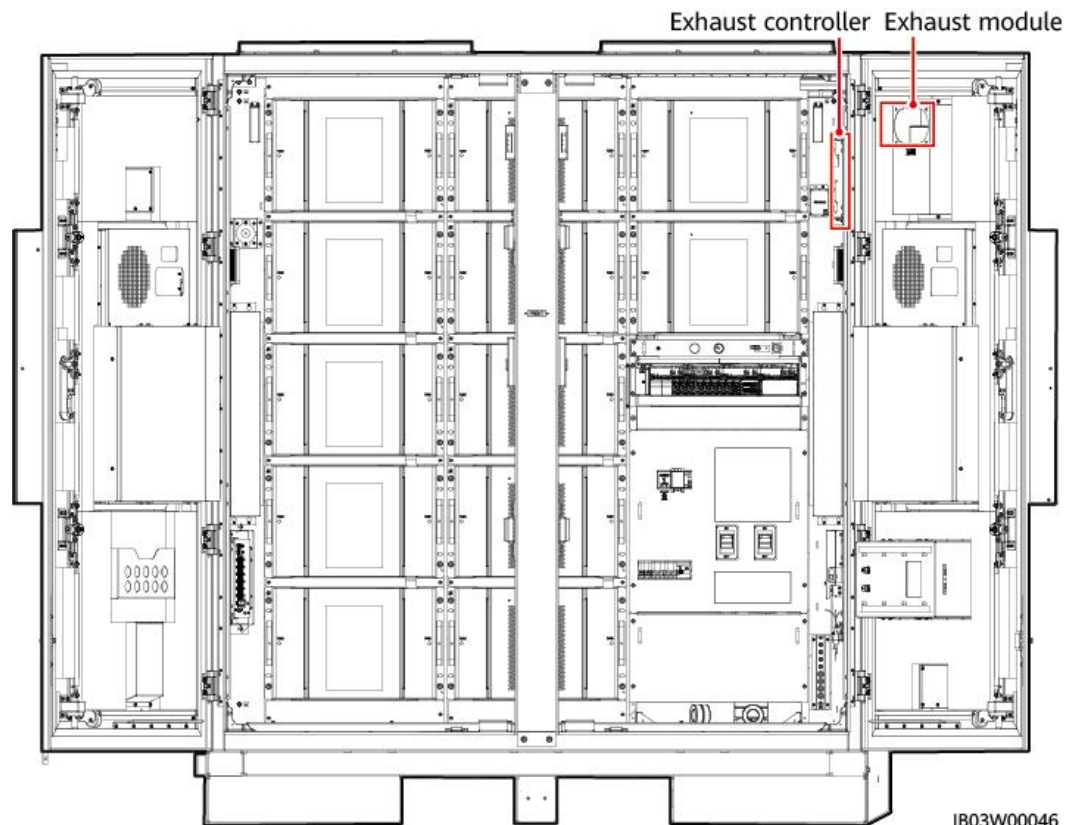

2.4.5.1 Exhaust Module

The exhaust module is the actuator of the active air exhaust system. When the combustible gas is released from the battery, the exhaust module reduces the concentration of combustible gas in the battery cabin.

Figure 2-28 Appearance

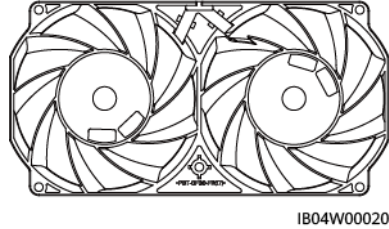

Technical Specifications	Exhaust Module
Dimensions (H x W x D)	38 mm x 194 mm x 99 mm
Operating voltage	36-72 V DC
Rated rotating speed	9500 RPM±10%
Operating temperature	-25°C to +70°C

2.4.5.2 Exhaust Controller

The exhaust controller TCUE receives commands from the CMU and adjusts the fan speed.

Figure 2-29 Appearance

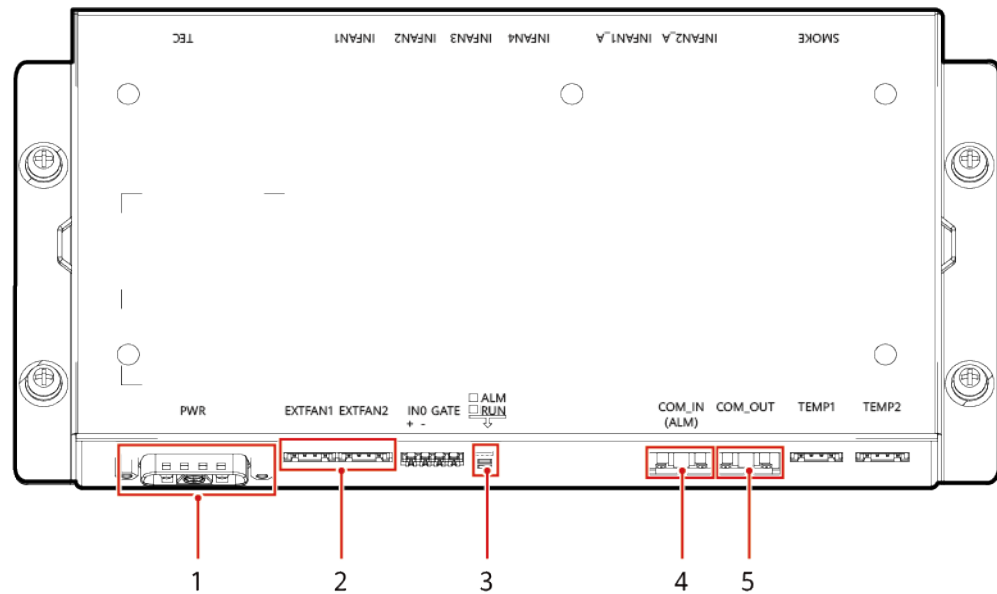

XW00000209

- (1) Power input port (2) Fan ports (3) Indicators
(4) Communications port 1 (5) Communications port 2 -

Table 2-20 Indicator description

Indicator	Color	Status	Description
RUN	Green	Steady on	Power supply to the board is normal but no program is running.
		Blinking (0.5 Hz)	The system is running properly.
		Blinking (4 Hz)	Serial port communication is interrupted or the board is not registered.
		Off	The system is not powered on.
ALM	Red	Steady on	Power supply to the board is normal but no program is running.
		Blinking (0.5 Hz)	An alarm is generated.
		Off	No alarm is generated.

2.5 Working Principle

2.5.1 Circuit Diagram

The 97 kWh, 129 kWh, and 161 kWh models require two fuses: 1F1 and 1F2. The 200 kWh model requires only fuse 1F1. The following figure shows the circuit diagram of the 200 kWh model.

Figure 2-30 Circuit diagram (200 kWh model)

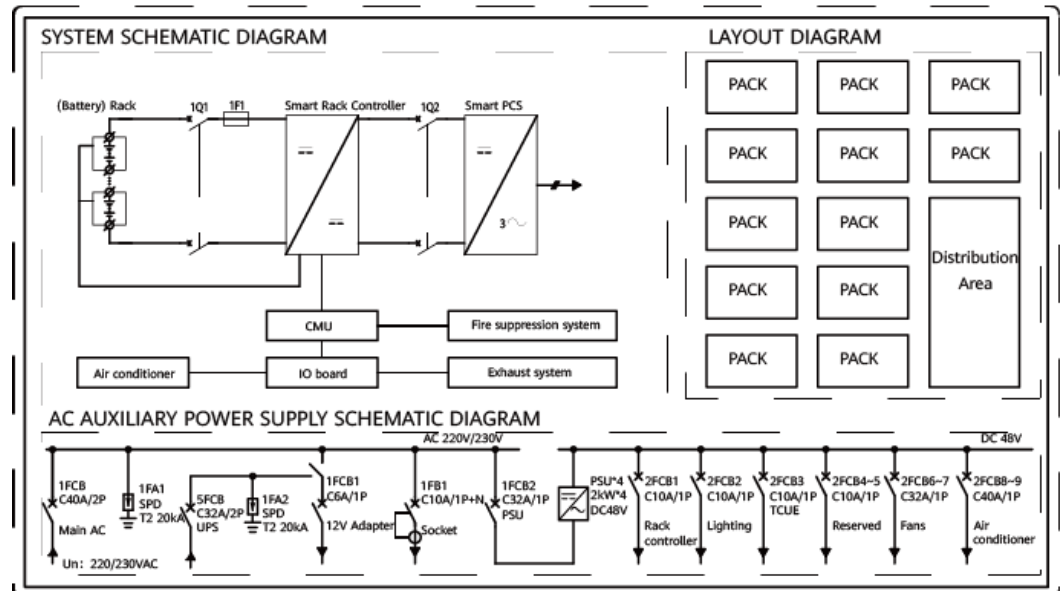

IB03P00004

2.5.2 Device Status

The ESS has six states: running, hibernating, self-checking, fault, offline, and loading.

Table 2-21 Device status description

Status	Description
Running	The ESS is charging from an external DC source or discharging for external devices.
Hibernating	The ESS stops charging and discharging and shuts down the rack controllers. <ul style="list-style-type: none"> In the running state, if the ESS receives a hibernation command, it enters the hibernation state. In the hibernation state, if the ESS receives a running command, it enters the running state.
Self-checking	The ESS is in progress of a self-check.
Fault	If a rack controller or battery pack is faulty, the system enters the fault state.
Offline	A rack controller is disconnected from the CMU.

Status	Description
Loading	After the CMU starts, the system is waiting for battery packs to be connected.

2.6 Networking Application

2.6.1 On-Grid Scenario

NOTE

In a PV+ESS scenario, one SmartLogger supports a maximum of 20 ESSs in parallel and 30 PV inverters.

Figure 2-31 Typical electrical connection diagram (components in the dotted box are optional)

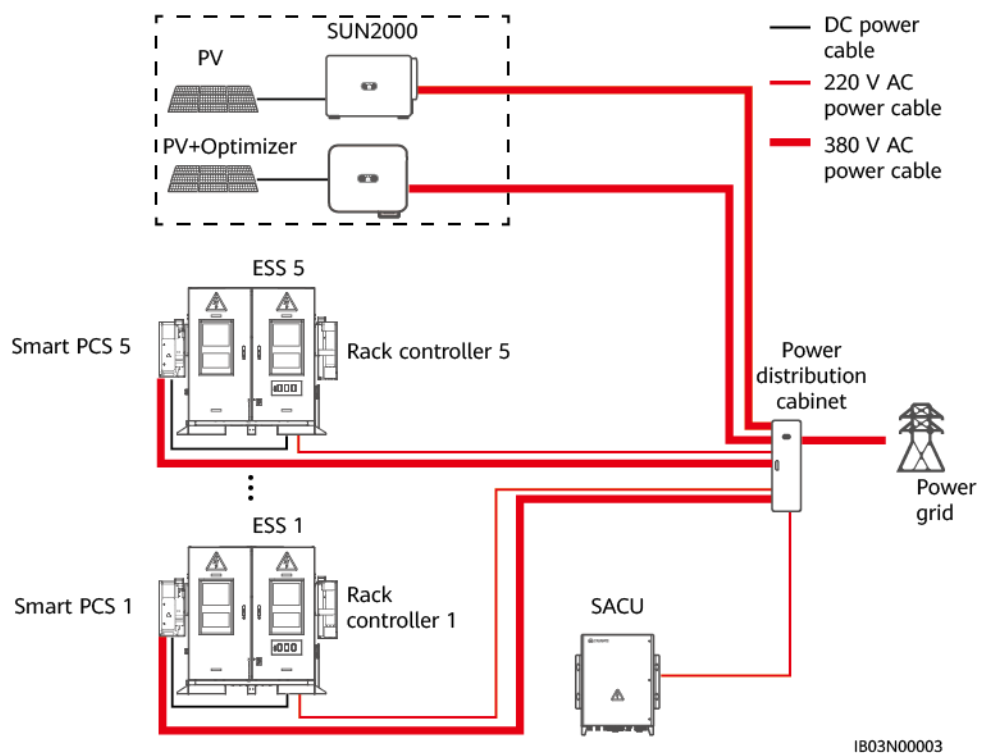

Table 2-22 1.0 MWh/500 kW standard solution configurations

No.	Name	Recommended Model/ Specifications	Quantity	Source
1	Smart String Energy Storage System (ESS)	LUNA2000-200KWH-2H1	5	Purchased from the Company

No.	Name	Recommended Model/ Specifications	Quantity	Source
2	Smart Power Control System (PCS)	LUNA2000-100KTL-M1	5	Purchased from the Company
3	Smart Rack Controller (rack controller)	-	5	Purchased from the Company
4	Smart Array Controller (SACU)	SmartACU2000D-D-00	1	Purchased from the Company
5	Power distribution cabinet	The specifications shall comply with the Smart PCS specifications, auxiliary power supply specifications, actual application scenarios, and local laws and regulations.	1	Prepared by the customer
6	Inverter	<ul style="list-style-type: none"> • SUN2000-(100KTL, 110KTL, 115KTL)-M2 • SUN2000-(20KTL, 29.9KTL, 30KTL, 36KTL, 40KTL)-M3 • SUN2000-(50KTL-ZHM3, 50KTL-M3) • SUN2000-(20KTL-M3, 33KTL-NH, 40KTL-NH) • SUN2000-50KTL-NHM3 • SUN2000-(75KTL, 100KTL, 110KTL, 125KTL) series • SUN2000-111KTL-NHM0 	Configured based on the capacity requirements	Prepared by the customer

Figure 2-32 Typical communication networking diagram (FE)

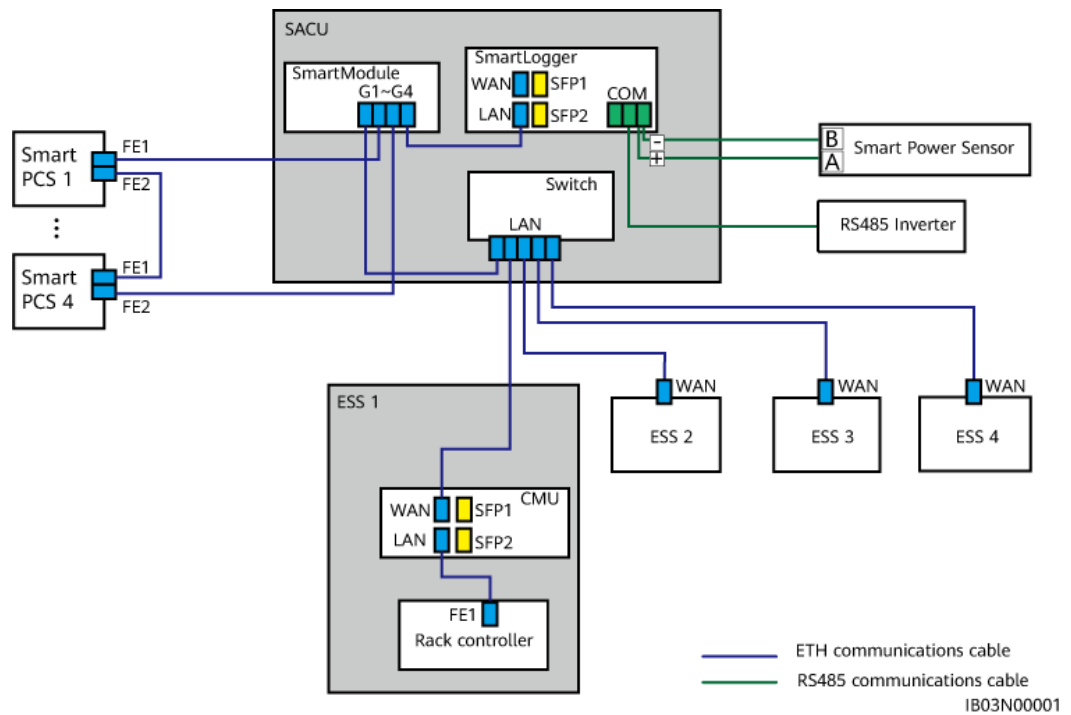
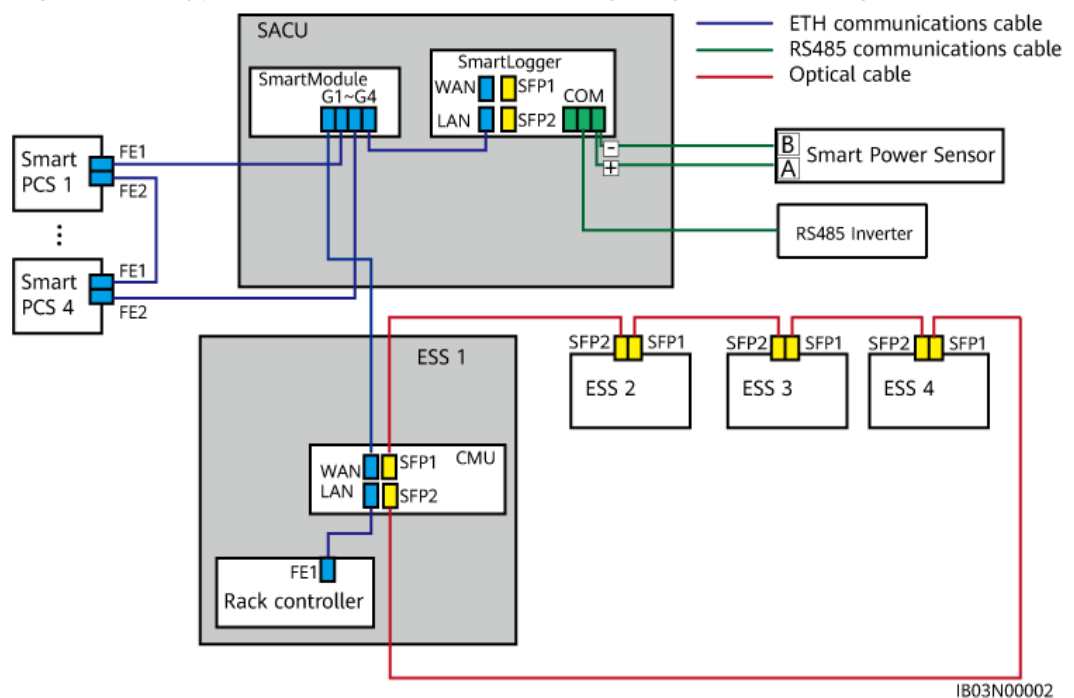

Figure 2-33 Typical communication networking diagram (fiber ring network)



NOTE

In the scenario with a single ESS, the Smart PCS communicates with the SACU through the FE1 port, as shown in [Figure 2-34](#).

Figure 2-34 Communication networking diagram (single ESS)

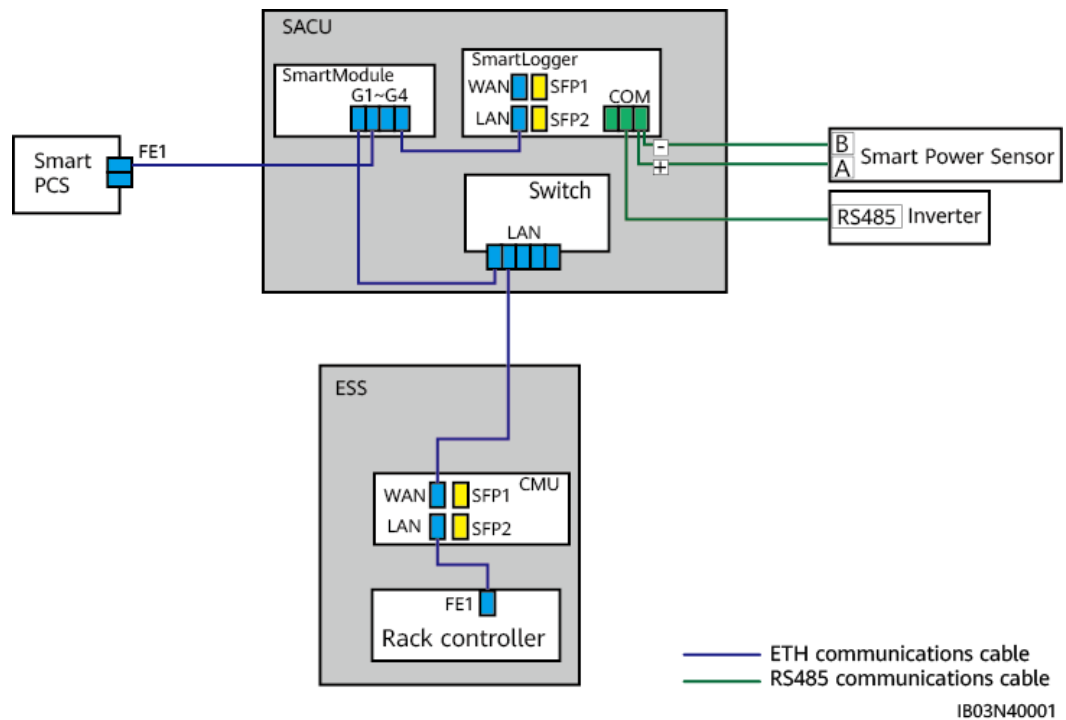

2.6.2 Microgrid Scenario

NOTICE

An insulation monitoring device (IMD) must be configured in microgrid scenarios (on/off-grid and off-grid). If no IMD is configured, safety risks exist in the ESS and the ESS restarts every 24 hours to perform the offline insulation resistance detection to ensure the ESS safety. During the restart, the microgrid cannot supply power to loads, resulting in microgrid collapses.

For details about the microgrid scenario, see [Commercial and Industrial Microgrid Energy Storage Solution Quick Guide \(With SmartLogger-based Microgrid Control\)](#) or [Commercial and Industrial Microgrid Energy Storage Solution Quick Guide \(With Third-Party Microgrid Central Controller\)](#).

3 Transportation Requirements

- Be cautious to prevent injury when moving heavy objects.



< 18 kg
(< 40 lbs)



18–32 kg
(40–70 lbs)



32–55 kg
(70–121 lbs)

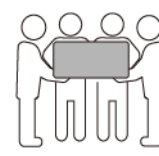

55–68 kg
(121–150 lbs)



> 68 kg
(> 150 lbs)

CZ0000110

- If multiple persons need to move a heavy object together, determine the manpower and work division with consideration of height and other conditions to ensure that the weight is equally distributed.
- If two persons or more move a heavy object together, ensure that the object is lifted and landed simultaneously and moved at a uniform pace under the supervision of one person.
- Wear personal protective gears such as protective gloves and shoes when manually moving the equipment.
- To move an object by hand, approach to the object, squat down, and then lift the object gently and stably by the force of the legs instead of your back. Do not lift it suddenly or turn your body around.
- Move or lift the equipment by holding its handles or lower edges. Do not hold the handles of modules that are installed in the equipment.
- Do not quickly lift a heavy object above your waist. Place the object on a workbench that is half-waist high or any other appropriate place, adjust the positions of your palms, and then lift it.
- Move a heavy object stably with balanced force at an even and low speed. Put down the object stably and slowly to prevent any collision or drop from scratching the surface of the equipment or damaging the components and cables.
- When moving a heavy object, be aware of the workbench, slope, staircase, and slippery places. When moving a heavy object through a door, ensure that the door is wide enough to move the object and avoid bumping or injury.
- When transferring a heavy object, move your feet instead of turning your waist around. When lifting and transferring a heavy object, ensure that your feet point to the target direction of movement.

- When transporting the equipment using a pallet truck or forklift, ensure that the tynes are properly positioned so that the equipment does not topple. Before moving the equipment, secure it to the pallet truck or forklift using ropes. When moving the equipment, assign dedicated personnel to take care of it.
- Ensure that tilt angle of the cabinet meets the requirements shown in the figure. The tilt angle α of a cabinet with packaging must be less than or equal to 15° . After the cabinet is unpacked, its tilt angle α must be less than or equal to 10° .

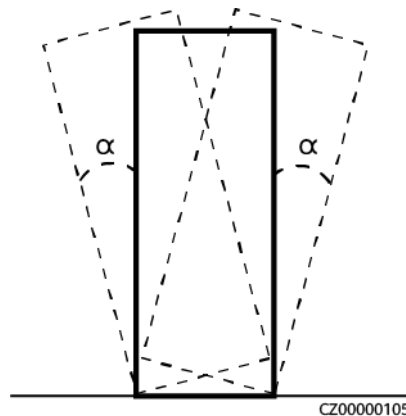

- When moving and transporting an air conditioner, keep it upright and do not place it horizontally or upside down. If the package of the air conditioner is damaged or the tilt indicator on the package changes color, contact the Company's service engineers.

Transportation Requirements

DANGER

Load or unload batteries with caution. Otherwise, the batteries may be short-circuited or damaged (such as leakage and crack), catch fire, or explode.

WARNING

Do not move a battery by holding its terminals, bolts, or cables. Otherwise, the battery may be damaged.

Keep batteries in the correct direction during transportation. They must not be placed upside down or tilted, and must be protected against falling down, mechanical impact, rains, snows, and falling into water during transportation.

Batteries must be transported separately. Do not transport a cabinet with batteries installed. If the cabinet needs to be transported or moved, remove the batteries first.

- According to the UN *Recommendations on the Transport of Dangerous Goods: Model Regulations* (also referred to as TDG or UN Orange Book), batteries belong to class 9 dangerous goods and shall pass the related tests

required in Part III Subsection 38.3 of the UN *Recommendations on the Transport of Dangerous Goods: Manual of Tests and Criteria*.

- Transportation and storage service providers must have the qualifications for dangerous goods operations required by local laws, regulations, and standards. Rigid box trucks shall be used for transportation and pickup trucks are prohibited.
- Batteries are delivered to the site directly and the road or sea transportation requirements shall be met.
- Comply with the latest international and national rules on the transportation and storage of dangerous goods, including but not limited to the *International Maritime Dangerous Goods Code (IMDG Code)*, *Agreement concerning the International Carriage of Dangerous Goods by Road (ADR)*, and China's transportation industry standards (JT/T 617) *Regulations concerning road transportation of dangerous goods*, as well as the requirements of the transportation regulatory authorities in the countries of departure, route, and destination. Before transportation and storage, properly pack, label, and mark products according to the local laws, regulations, and standards, and complete related product and packaging tests.
- Choose sea or roads in good conditions for transportation. Do not transport the equipment by railway or air. Avoid tilt or jolt during transportation.
- Before transportation, ensure that the battery packaging, labels, and markings are intact and there is no abnormal smell, leakage, smoke, or fire. Otherwise, the batteries must not be transported.
- The packing case must be solid and strong. Handle the packages with care and take moisture-proof measures during loading, transportation, and unloading. Do not place the packages on one side or upside down. Bind the packages securely to avoid displacement. Ensure that the dangerous goods labels are visible.
- Exercise caution when moving batteries to prevent bumping and ensure personal safety.
- Unless otherwise specified, dangerous goods must not be mixed with goods containing food, medicine, animal feed, or their additives in the same vehicle or container.
- If the local laws, regulations, and standards allow the mixed transportation of specified different dangerous goods and that of dangerous goods and common goods, the dangerous goods shall be isolated according to the local laws, regulations, and standards. If there is no specific local requirement, refer to the following requirements for isolation when dangerous goods and common goods are in the same vehicle or container:
 - Use a spacer that is as high as the packages.
 - Keep a distance of at least 0.8 m around.
- Before transporting a faulty battery (with scorch, leakage, bulge, or water intrusion), insulate its positive and negative terminals, pack it, and place it in an insulated explosion-proof box as soon as possible. Record information such as the site name, address, time, and fault symptom on the box.
- When transporting faulty batteries, avoid approaching flammable material storage areas, residential areas, or other densely populated places, such as mass transit facilities or elevators.

4 Storage Requirements

General Requirements

NOTE

- Proof that the product is stored according to the requirements must be available, such as temperature and humidity log data, storage environment photos, and inspection reports.
- Do not store battery packs for extended periods. Long-term storage of lithium batteries may cause capacity loss. Generally, the irreversible capacity loss is 3% to 10% after the lithium batteries are stored at the recommended storage temperature range for 12 months.
- The storage environment must be clean and dry. The product must be protected against rain and water.
- The air must not contain corrosive or flammable gases.
- Do not tilt the product or place it upside down.
- If equipment except battery packs has been stored for more than two years, it must be checked and tested by professionals before use.

4.1 ESS (Excluding Battery Packs) Storage

- Do not unpack an ESS if it will be stored for a long time.
- Do not stack the ESSs.
- Ensure that the ground surface is flat (for long-term or temporary storage).
- Close the cabinet door.
- Storage temperature: -40°C to +60°C; relative humidity: 5%–95% RH

4.2 Battery Pack Storage and Single Battery Pack Charge

Material Delivery Check

There must be a battery charge label on the packing case. The charge label must specify the latest charge time and the next charge time.

Storage Requirements



WARNING

- Ensure that batteries are stored in a dry, clean, and ventilated indoor environment that is free from sources of strong infrared or other radiations, organic solvents, corrosive gases, and conductive metal dust. Do not expose batteries to direct sunlight or rain and keep them far away from sources of heat and ignition.
- If a battery is faulty (with scorch, leakage, bulge, or water intrusion), move it to a dangerous goods warehouse for separate storage. The distance between the battery and any combustible materials must be at least 3 m. The battery must be scrapped as soon as possible.
- Place batteries correctly according to the signs on the packing case during storage. Do not place batteries upside down, lay them on one side, or tilt them. Stack batteries in accordance with the stacking requirements on the packing cases.
- Store batteries in a separate place. Do not store batteries together with other devices. Do not stack batteries too high. The site must be equipped with qualified fire fighting facilities, such as fire sand and fire extinguishers.
- After batteries are powered off, static power consumption and self-discharge loss may occur in internal modules, which may cause battery damage due to overdischarge. Do not store batteries in low SOC and charge batteries in a timely manner. Permanent battery faults caused by delayed charge are not covered by the warranty. Storing the batteries in low SOC occurs in scenarios including but not limited to the following:
 - The power cables or signal cables are not connected.
 - The batteries cannot be charged due to a system fault after discharge.
 - The batteries cannot be charged due to incorrect configurations in the system.
 - The batteries cannot be charged due to long-term mains failure.
 - The batteries cannot be charged because the switch of the Smart Rack Controller, Smart PCS, or main loop component is off.

CAUTION

It is recommended that batteries be used soon after being deployed onsite. Batteries that have been stored for an extended period shall be charged periodically. Otherwise, they may be damaged.

-
- Packaging label description

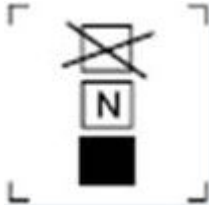
Label	Description
	<p>This way up: The package shall be vertically oriented during transport and storage.</p>
	<p>Fragile: The package contains fragile objects and shall be handled with care.</p>
	<p>Keep dry: The package shall be kept away from rain.</p>
	<p>Stacking limit by number: The packages shall not be vertically stacked beyond the specified number. The actual label may vary.</p>

- The storage environment requirements are as follows:
 - Ambient temperature: -40°C to $+60^{\circ}\text{C}$ (0°C to 30°C are recommended. If batteries are stored at a temperature higher than 40°C for extended periods, the battery performance and service life may be deteriorated.)
 - Relative humidity: 5%–95% RH (recommended: about 45% RH)
 - Dry, clean, and well-ventilated
 - Away from corrosive organic solvents and gases
 - Away from direct sunlight
 - At least 2 m away from heat sources
- The batteries in storage must be disconnected from external devices. The indicators (if any) on the batteries must be off.
- The storage duration starts from the latest charge time labeled on the battery package. If a battery is qualified after charge, update the latest charge time (recommended format: YYYY-MM-DD HH:MM) and the next charge time (Next charge time = Latest charge time + Charge interval) on the label.
- The following table lists the maximum charge intervals for batteries delivered separately. Charge the batteries promptly and calibrate the SOC to at least 50%. Otherwise, the battery performance and service life may be deteriorated.

Storage Temperature (T)	Maximum Charge Interval ^a
$-40^{\circ}\text{C} < T \leq +30^{\circ}\text{C}$	15 months
$30^{\circ}\text{C} < T \leq 40^{\circ}\text{C}$	11 months
$40^{\circ}\text{C} < T < 60^{\circ}\text{C}$	7 months
Note a: The interval starts from the latest charge time labeled on the battery package.	

- When stored in low SOC, the batteries must be charged within the maximum interval corresponding to the SOC when the batteries are powered off. If the batteries are not charged within the specified interval, they may be damaged due to overdischarge.

Power-Off SOC Before Storage	Maximum Charge Interval
$\text{SOC} \geq 50\%$	Refer to the charge intervals for batteries delivered separately.
$5\% \leq \text{SOC} < 50\%$	20 days
$\text{SOC} < 5\%$	48 hours

- Do not unpack batteries. If charging is necessary, they must be charged by professionals as required and then returned to their original packaging after charging.
- The warehouse keeper shall collect battery storage information every month and periodically report the battery inventory information. The batteries in long-term storage shall be charged in a timely manner.

 **CAUTION**

- Only trained and qualified personnel are allowed to charge batteries. Wear insulated gloves and use dedicated insulated tools during the operation.
 - Observe onsite during charge and handle any exceptions in a timely manner.
 - If a battery experiences an abnormality such as bulging or smoking during charge, stop charging immediately and dispose of it.
-
- AC mains input voltage requirements for charging:
 - 220 V (three-phase 260–530 V AC or single-phase 176–300 V AC)
 - 110 V (three-phase 130–265 V AC or single-phase 90–175 V AC)
 - AC input power cables used for charging in the warehouse must have a through-current capacity greater than 23 A.
 - If batteries have been stored for longer than allowed, promptly report the event to the person in charge.
 - Ensure that batteries are delivered based on the "first in, first out" rule.

- Handle batteries with caution to avoid damage.

Conditions for Determining Overdue Storage of Battery Packs

- Do not store batteries for extended periods.
- The following table lists the maximum charge intervals for batteries delivered separately. Charge the batteries promptly and calibrate the SOC to at least 50%. Otherwise, the battery performance and service life may be deteriorated.

Storage Temperature (T)	Maximum Charge Interval ^a
$-40^{\circ}\text{C} < T \leq +30^{\circ}\text{C}$	15 months
$30^{\circ}\text{C} < T \leq 40^{\circ}\text{C}$	11 months
$40^{\circ}\text{C} < T < 60^{\circ}\text{C}$	7 months

Note a: The interval starts from the latest charge time labeled on the battery package.

- If batteries have been stored for longer than allowed, promptly report the event to the person in charge.
- Dispose of deformed, damaged, or leaking batteries directly irrespective of how long they have been stored.
- The storage duration starts from the latest charge time labeled on the battery package. If a battery is qualified after charge, update the latest charge time (recommended format: YYYY-MM-DD HH:MM) and the next charge time (Next charge time = Latest charge time + Charge interval) on the label.
- Batteries can be charged for a maximum of three times during storage. Dispose of batteries if the maximum charge times are exceeded.

Preparing Charging Devices

- Multimeter
- Clamp meter
- Insulated torque socket wrench
- Charger

Inspection Before Charge

1. Before charging a battery, you need to check its appearance. Charge the qualified battery or dispose of the unqualified one.
2. The battery is qualified if it is free from the following symptoms:
 - Deformation
 - Shell damage
 - Leakage
3. Check that the accessories are complete based on the packing list delivered with the charger.

Full Charge Strategy

The charging ambient temperature ranges from 15°C to 40°C.

Charge and Discharge Current (Unit: Ampere)	Charging Duration (Excluding Equalization)
20	24 hours (fully discharge the battery and then charge the battery to 50% SOC)
40 ^[1]	12 hours (fully discharge the battery and then charge the battery to 50% SOC)
Note 1: In customized mode, use the AC 220 V/20 A (6 mm ²) power cable delivered with the charger.	

Charging Procedure

NOTE

Prepare the battery qualified for charge.

- Step 1** Connect the communications port on the charger to the COM-2 and 48V-2 ports on the battery using the CAN communications cable (48 V) delivered with the charger.
- Step 2** Connect the positive and negative cable ports on the charger to the positive and negative ports on the battery using the positive and negative DC input power cables delivered with the charger.
- Step 3** Connect the AC INPUT port on the charger to the utility power source using the power cable delivered with the charger.
- Step 4** Turn on the AC circuit breaker of the charger.
- Step 5** Turn on the DC circuit breaker of the charger.
- Step 6** Operate the charger according to its manual.
- Step 7** After the charge and discharge are complete, wait until the fan in the charger keeps running for about 5 minutes to dissipate the residual heat, turn off the AC and DC circuit breakers, and remove the cables.

----End

4.3 Smart Rack Controller Storage

If a Smart Rack Controller will not be used immediately, store it according to the following requirements:

- Do not remove the packaging. Check the packaging regularly (recommended: once every three months). Replace any packing materials that become damaged during storage. If the Smart Rack Controller is unpacked but will not

be used immediately, put it back to the original packaging with the desiccant, and seal with tape.

- Storage temperature: -40°C to $+70^{\circ}\text{C}$; relative humidity: 5%–95% RH
- Stack Smart Rack Controllers with caution to prevent them from falling over, resulting in personal injury or equipment damage.

5 Site Requirements

5.1 Site Selection Requirements

NOTICE

Refer to the *NFPA 855 Standard for the Installation of Stationary Energy Storage Systems* and local laws and regulations.

5.1.1 General Requirements

- The horizontal level of the installation site shall be above the highest water level of that area in history and at least 300 mm above the ground. The site must not be located in a low-lying land.
- The ESS and the site must be in an environment free from explosion risks.
- Transportation to the site shall be convenient and fire suppression facilities shall be reliable.

NOTE

- When installing, commissioning, and operating the ESS, ensure that at least two gas fire extinguishers, such as heptafluoropropane, perfluorohexanone, or carbon dioxide fire extinguishers, are provided near each unit to ensure fire safety.
- Reserve sockets for the water fire suppression system at the ESS site.
- The site area must meet the requirements and there shall be space for capacity expansion.
- The ESS shall be installed more than 30 m away from the third-party wireless communication facilities.
- The site shall be in a well-ventilated place.

Do not select the sites that are not recommended by industry standards and regulations, including but not limited to the following areas:

- Areas with sources of strong vibration, loud noises, and strong electromagnetic interference

- Areas with dust, oil fumes, harmful gases, corrosive gases, etc.
- Areas with corrosive, flammable, and explosive materials
- Areas with existing underground facilities
- Areas with adverse geological conditions such as rubbery soil and soft soil layer, or prone to waterlogging and land subsidence
- Under a reservoir, water landscape, and water room

 NOTE

- If areas prone to waterlogging cannot be avoided, install water blocking and drainage facilities or raise the ground.
- Cable trenches shall not be used for drainage. Fire retardant sealing shall be implemented at cable holes (such as holes through partition walls and floors).
- Areas prone to earthquakes and with seismic fortification intensity higher than 9
- Areas prone to debris flow, landslide, quicksand, karst caves, and other direct hazards
- Areas within the mining land subsidence (dislocation) zone
- Areas within the scope of blasting hazard
- Areas prone to flood due to a dam or levee failure
- Protection areas for important water supply sources
- Protection areas for historic relics
- Populated areas, high-rise buildings, and underground buildings
- Intersections and busy roads of urban main roads

Requirements for flood and waterlogging prevention in site selection:

- The site design elevation of a large-scale electrochemical energy storage system (power ≥ 100 MW) shall be higher than the flood level with a probability of 1% or the historical highest waterlogging level.
- The site design elevation of a medium- or small-scale electrochemical energy storage system (power < 100 MW) shall be higher than the flood level with a probability of 2% or the historical highest waterlogging level.
- If the site design elevation cannot meet the preceding requirements, change the site location or take different flood and waterlogging prevention measures based on the site requirements.
- For energy storage plants prone to wind and waves from rivers, lakes, and seas, the elevation of flood prevention facilities shall consider the wind and wave height with a probability of 2% and an additional safety height of 0.5 m.
- When a large amount of catchment water flows into or passes through the site, it is recommended that side ditches or drainage ditches be built to drain water from the ground in an organized manner.

5.1.2 Outdoor Requirements

The general requirements for selecting an outdoor ESS site are as follows:

- There must be no vegetation, especially flammable plants within 3 m of the ESS or the site to protect the ESS from possible fires. (Exemption: Single

specimens of trees, shrubbery, or cultivated ground cover such as green grass, ivy, succulents, or similar plants used as ground covers shall be permitted to be exempt provided that they do not form a means of readily transmitting fire.)

- No obstacle shall be above the ESS. For example, the ESS must not be installed under a parking shed and PV modules must not be installed on the top of the ESS.
- The safety distances between the ESS and buildings shall comply with local fire protection regulations or standards.
 - The ESS located outdoors must be at least 10 ft (3.048 m) away from lot lines, public ways, buildings, combustible materials, hazardous materials, high-piled stock, parking spaces, and other exposure hazards not associated with electrical grid infrastructure.
 - If either of the following conditions is met, the distance between the ESS and the production building shall be permitted to be reduced to 3 ft (0.914 m). In addition, clearance requirements for equipment transportation, installation, and maintenance shall be considered.
 - There are 1-hour freestanding fire walls, extending 5 ft (1.5 m) above and extending 5 ft (1.5 m) beyond the physical boundary of the ESS installation.
 - Non-combustible exterior walls with no openings or combustible overhangs are provided on the walls adjacent to the ESS and the fire resistance rating of the exterior walls complies with 2-hour fire resistance rating of ASTM E119 or UL 263.
 - The distance between the exhaust device of an ESS and the heating and ventilation vents, air intake vents of air conditioners, windows, doors, unloading platforms, and fire sources of other buildings or facilities must be greater than 4.6 m.
- The ESS cannot be installed in salt-affected or polluted areas because this will cause corrosion. The ESS can be used in the following or better environments:
 - Outdoor environment more than 2000 m away from the coast. You are advised not to use the ESS in an area 500 m to 2000 m away from the coast. (If you need to use it, confirm with the vendor or the Company's engineers.) If the site is less than 500 m away from the coast, outdoor deployment is not allowed. Install the ESS indoors according to [Indoor Requirements](#).
 - More than 1500–3000 m away from heavy pollution sources such as smelteries, coal mines, and thermal power plants
 - More than 1000–2000 m away from medium pollution sources such as chemical, rubber, and electroplating industries
 - More than 500–1000 m away from light pollution sources such as packing houses, tanneries, boiler rooms, slaughterhouses, landfill sites, and sewage treatment plants

 **NOTE**

You are advised to select another site if the safety distance for a site cannot meet the requirements of relevant national standards.

Security fencing:

It is recommended that physical walls or fences be used for isolation and protection in the energy storage equipment area. The fences shall be equipped with a door lock and the recommended fence height is greater than 2.2 m. Fire walls shall be permitted to be substituted for part or all of the fences, depending on the actual design plans.

5.1.3 Indoor Requirements

The fire safety of the ESS dedicated-use buildings or structures must comply with local laws and regulations. Refer to standards including but not limited to NFPA 855 and comply with the following requirements:

- An ESS dedicated-use building or structure is required, with a 2-hour fire resistance rating for the walls and a maximum of 600 kWh lithium batteries stored per fire protection unit. The building or structure shall meet relevant requirements.
 - The building or structure shall only be used for the operation of the ESS equipment.
 - Occupants in the rooms and areas containing the ESS shall be limited to personnel that operate, maintain, service, test, and repair the ESS and other energy systems.
 - No other occupancy types shall be permitted in the building or structure.
- The distance between the ESS dedicated-use building or structure and the following places shall be greater than or equal to 3.0 m: lot lines, stored combustible materials, hazardous materials, high-piled stock, electrical infrastructure, public ways, buildings, and parking spaces.
- The layout in the ESS dedicated-use building or structure shall comply with local fire protection laws, regulations, and standards, such as the safe distance and layout of buildings and materials in various production scenarios.
- Combustible materials shall not be stored in the ESS dedicated-use building or structure. The distance between the combustible materials and the building or structure shall be greater than or equal to 3 m.
- The ESS dedicated-use building or structure shall be equipped with fire extinguishers filled with halogenatedane, heptafluoropropane, perfluorohexanone, carbon dioxide, or dry powder. Each fire protection unit shall be equipped with at least two fire extinguishers, which shall be checked and replaced periodically.
- The ESS dedicated-use building or structure shall be configured with room-level smoke detectors. At least two detectors of each type shall be configured, and the automatic fire alarm system shall be enabled.
- The ESS dedicated-use building or structure shall be equipped with independent ventilation devices. The ventilation devices shall interact with the fire alarm system and limit the concentration of flammable gas to below 25% of the lower flammability limit (LFL). The mechanical exhaust ventilation rate shall be greater than or equal to 1 ft³/min/ft² (5.1 L/sec/m²).
- The ESS dedicated-use building or structure shall be equipped with room-level flammable gas detection devices. Rooms containing the ESS shall be protected by an approved continuous gas detection system that complies with the following:

- The gas detection system shall be designed to activate the mechanical exhaust ventilation system when the level of flammable gas detected in the rooms exceeds 25% of the LFL.
- The mechanical exhaust ventilation system shall remain on until the flammable gas detected is less than 25% of the LFL.
- The gas detection system shall be provided with a minimum of 2 hours of standby power.
- Failure of the gas detection system shall annunciate a trouble signal at the monitoring center.
- The ESS dedicated-use building or structure shall be equipped with fire suppression facilities such as water spray or sprinkler systems. The water stored shall be able to supply for more than 2 hours at the designed water flow rate and the surrounding water source shall be able to supply water continuously for 12 hours to cope with the risk of reignition or fire spreading after a battery fire is extinguished. The water spray or sprinkler systems shall be designed using a minimum density of 0.3 gpm/ft² (12.2 mm/min) based over the area of the room or 2500 ft² (230 m²) design area, whichever is smaller.
- The ESS dedicated-use building or structure shall be equipped with pressure relief explosion-proof devices or pressure relief channels (such as glass windows and magnetic lock doors) with equivalent areas. According to the NFPA 68 standard, if side pressure relief is adopted, a protective fence or wall shall be installed outside the pressure relief channels, and the fence or wall shall be at least 3 m away from the pressure relief wall.
- The ambient temperature inside the building where the ESS is located shall be lower than 55°C when the ESS is running.
- The indoor ceiling height of the building or structure shall be at least 4.5 m. A minimum of 2 m clearance above the ESS shall be reserved for pressure relief and no flammable materials shall be placed above the ESS.
- Maintenance clearances:
 - The entrance and exit doors shall meet the clearance requirements for installing the ESS using a forklift.
 - The indoor area of the building shall meet the clearance requirements for the ESS maintenance and forklift operations.
- Exits and aisles:
 - Safety exits and aisles shall be set for all areas containing the ESS in accordance with the local building code.
 - Emergency lighting shall be provided for all exit doors and aisles in accordance with the local building code.
 - All exit doors shall be opened toward the exit direction.
- Exemption conditions:
 - The preceding installation requirements shall be in line with the requirements approved by the local fire department. On the premise that the fire department approval is obtained, the requirements on water sprinkler systems, smoke detection, flammable gas detection, and explosion-proof can be exempt. However, the requirements on mechanical exhaust ventilation, pressure relief clearance above the ESS, heat dissipation, and maintenance clearance shall be met.

- When approved by the fire department, the fire control and suppression systems, size and separation requirements, and the water supply shall be permitted to be omitted in ESS dedicated-use buildings located more than 100 ft (30.5 m) from buildings, lot lines that can be built upon, public ways, stored combustible materials, hazardous materials, high-piled stock, and other exposure hazards not associated with electrical grid infrastructure.
- Requirements for offshore indoor applications:
 - If the ESS is less than 500 m away from the coast, ensure that it is located in an indoor environment within a dedicated protective building that has controllable temperature and humidity using air conditioners. The indoor environment must meet the C4 or higher level specified in ISO 12944/ISO 9223. In addition, the preceding site selection requirements for indoor applications must be met.
 - Anti-salt fog measures must be taken for outdoor air conditioners and mechanical ventilation devices. Anti-salt fog filters must be installed at the air intake and exhaust vents, or anti-salt fog air conditioners or ventilation devices must be used. The filters must be maintained and replaced periodically.

5.2 Clearance Requirements

NOTICE

The following figure shows the minimum clearance requirements for installation and O&M. The equipment clearances must also meet the site selection requirements (see [5.1 Site Selection Requirements](#)).

Figure 5-1 Clearance requirements (ball transfer platform)

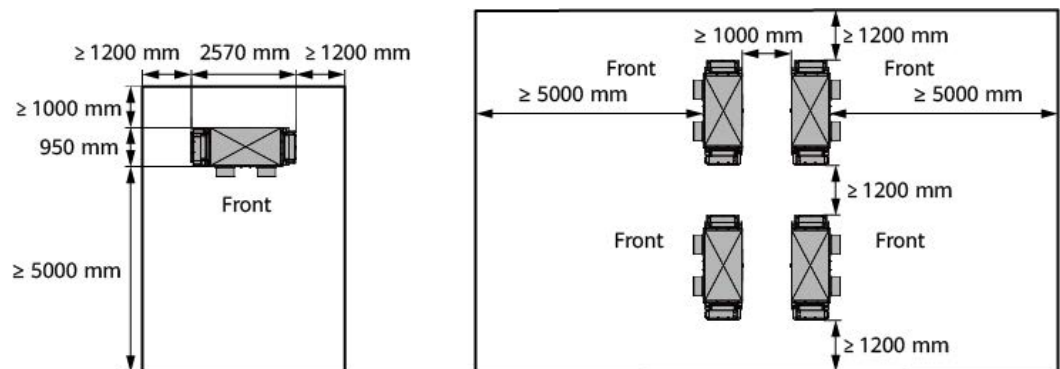

1B03W00050

Figure 5-2 Clearance requirements (sliding rack shelf)

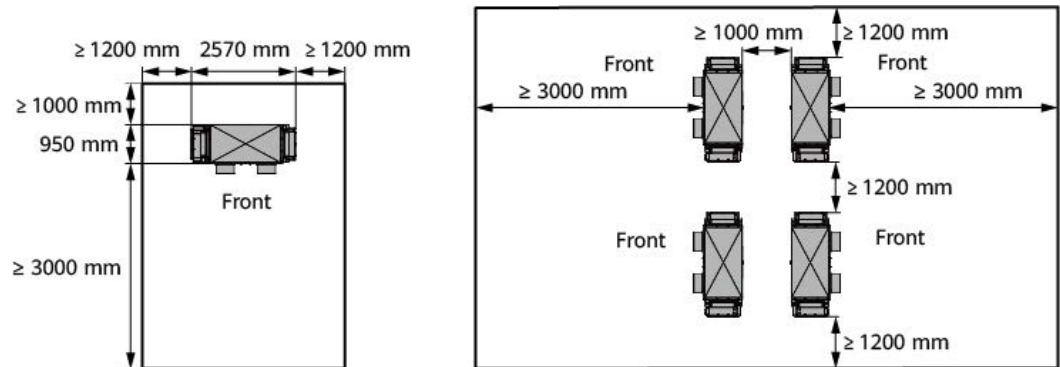

IB03W00081

5.3 Foundation Requirements

Requirements for foundation design solution:

- The ESS must be installed on concrete or other non-combustible surfaces. Ensure that the installation surface is horizontal, secure, flat, and has sufficient load-bearing capacity. Subsidence or slope is not allowed.
- The foundation shall sustain the total weight of the equipment. If the load-bearing capacity of the foundation does not meet the requirement, a review is required.
- The bottom of the excavated foundation must be compacted and flat.
- After the foundation is excavated, prevent water from entering the foundation. If water enters the foundation, excavate and refill the affected parts.
- The level tolerance between the foundation and the contact surface of the cabinet must be less than or equal to 3 mm.
- The foundation must be above the highest water level of the local area in history and at least 300 mm above the ground.
- Construct drainage facilities based on the local geological conditions and municipal drainage requirements to ensure that no water will accumulate at the equipment foundation. The foundation construction must meet the local drainage requirements for the maximum historical rainfall. The drained water must be disposed of in accordance with local laws and regulations.
- Reserve trenches or cable inlets for the ESS during foundation construction.
- The reserved holes on the foundation and the cable inlets at the bottom of the equipment shall be sealed.
- The foundation drawings shall not be used as the final construction drawings and are for reference only. For details, contact the product manager of the Company to obtain the foundation drawings. The design specifications of the ESS foundation shall be reviewed based on the installation environment, ground bearing capacity, geological features, and seismic resistant requirements of the project site.

Figure 5-3 Foundation requirements (without the required ground bearing capacity)

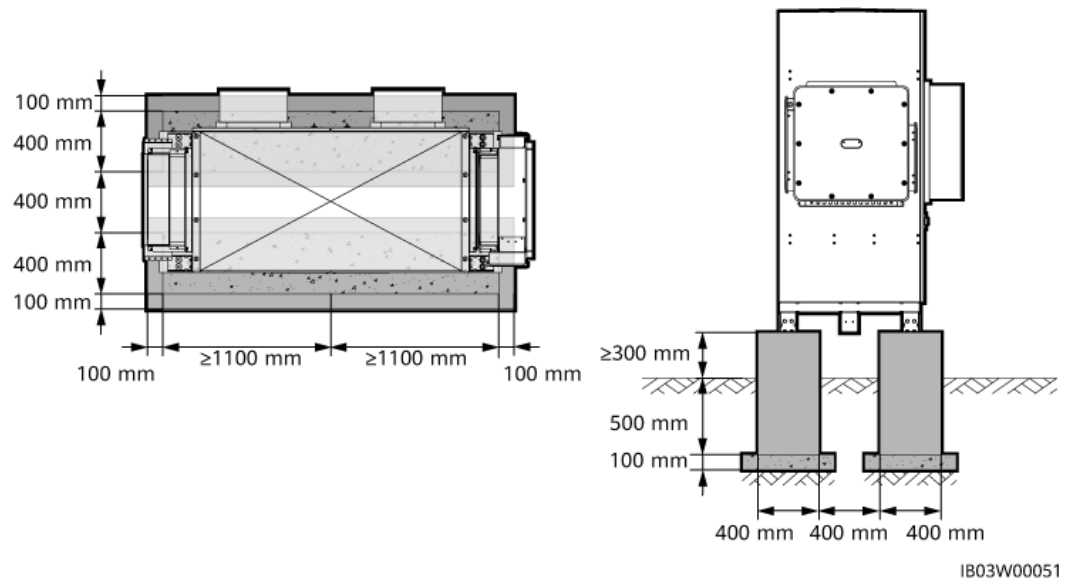
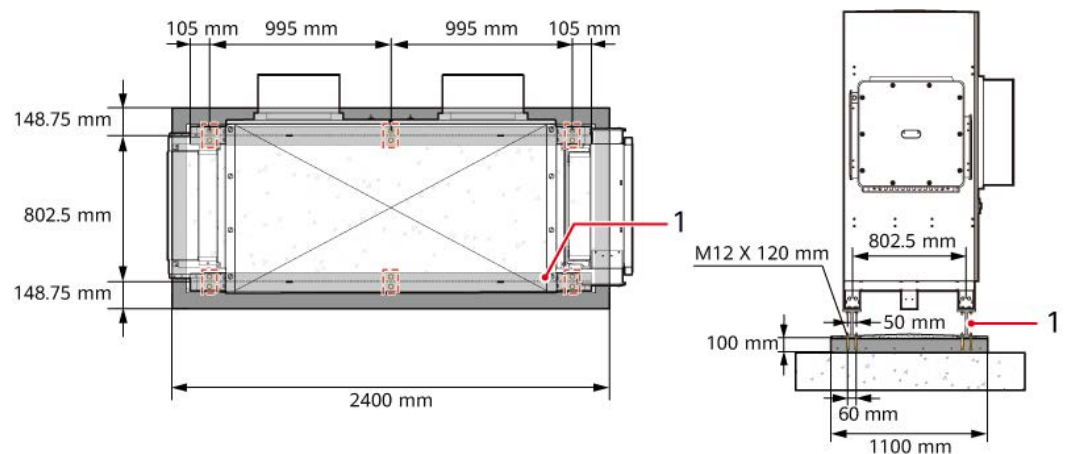

Figure 5-4 Foundation requirements (with the required ground bearing capacity)



(1) H-shaped steel beam

5.4 Forklift Requirements

- Do not move the ESS after battery packs are installed.
- If a forklift is used to install the ESS cabinet, ensure that the forklift has a load-bearing capacity of at least 2 t.
- If a forklift is used to install and maintain battery packs, ensure that the forklift has a load-bearing capacity of at least 1 t.
- It is recommended that the length of the tynes be 1200–1500 mm, the width be 80–160 mm, and the thickness be 25–80 mm.
- Lifting height of a forklift: If the foundation is less than or equal to 0.3 m high, the lifting height shall be greater than or equal to 2 m. If the foundation is greater than 0.3 m high, the lifting height shall be increased accordingly.

5.5 Hoisting Requirements

- Before hoisting, ensure that the crane and hoisting ropes meet the load-bearing requirements.
- When installing or removing the hoisting equipment, do not drag it on the cabinet to prevent scratches.
- Do not hoist or move the ESS after battery packs are installed.

Stage	Precautions
Before hoisting	Crane hoisting capacity ≥ 2 t, working radius ≥ 2 m. If the onsite environment does not meet the required working conditions, ask a professional to assess the conditions.
	Only trained and qualified personnel are allowed to perform hoisting operations.
	Check that hoisting tools are complete and in good condition.
	Ensure that the hoisting tools are secured to a load-bearing object or wall.
	When the equipment is used outdoors, it is recommended that you hoist the equipment when the weather is good and there is no wind.
	Ensure that the crane and steel ropes meet the requirements before the hoisting.
	All doors of the equipment are closed and locked.
	Ensure that the steel hoisting ropes are securely connected.
	It is recommended that the equipment be hoisted from left to right or from right to left.
During hoisting	Do not allow any unauthorized person to enter the hoisting areas and do not stand under the crane arm.
	Ensure that the crane is properly located and avoid long-distance hoisting.
	Keep the cabinet stable and horizontal during hoisting, and ensure that the diagonal gradient of the cabinet is less than or equal to 5 degrees.
	Ensure that the angle between two ropes is less than or equal to 90 degrees.
	Lift and land the cabinet slowly to prevent shock to equipment inside it.
	Remove the ropes after ensuring that the cabinet is placed evenly on the cabinet base.

Stage	Precautions
	Do not drag steel ropes or lifting appliances. Do not collide with the equipment.
	Secure the cabinet you have hoisted before hoisting another cabinet.

6 Unpacking and Acceptance

NOTICE

- To prevent the equipment from falling over, secure it to a pallet truck or forklift using ropes before moving it. Move the equipment with caution to avoid bumping or falling, which may damage the equipment.
 - After placing the equipment in the installation position, unpack it with care to prevent scratches. Keep the equipment stable during unpacking.
 - After unpacking, check whether the fastening components and removable components are loose. If they are loose, notify the carrier and manufacturer immediately.
 - Before unpacking batteries, check whether the packaging is intact. Do not use batteries with damaged packaging. If any damage is found, notify the carrier and manufacturer immediately.
 - If the installation environment is poor, take dustproof and anti-condensation measures (for example, use a dust cover, plastic film, or fabric cloth) after unpacking batteries to prevent condensation and dust buildup, which may corrode the batteries.
-

7 Installation









7.1 Installation Preparations

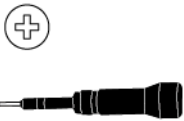

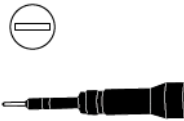
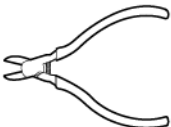
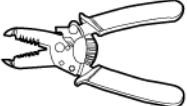



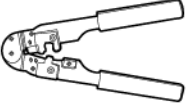
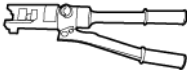

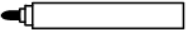

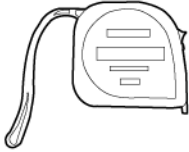
7.1.1 Preparing Tools

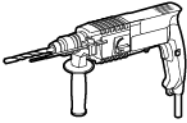
 NOTE



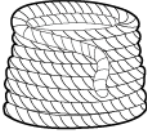

- The tool pictures are for reference only.
- The tool tables may not list out some tools required onsite. Onsite installation personnel and the customer need to prepare the tools based on the site requirements.

Installation Tools

 <p>Phillips insulated torque screwdriver</p>	 <p>Insulated torque socket wrench (including an extension bar)</p> <ul style="list-style-type: none"> • Socket specifications: 7–19 mm • Socket depth \geq 32 mm • The socket connector matches the torque wrench. • Torque range: 1.2–45 N·m 	 <p>Flat-head insulated torque screwdriver</p>	 <p>Diagonal pliers</p>
 <p>Wire stripper</p>	 <p>Cable cutter</p>	 <p>Rubber mallet</p>	 <p>Utility knife</p>
 <p>RJ45 crimping tool</p>	 <p>Hydraulic pliers</p>	 <p>Multimeter DC voltage measurement range \geq 1500 V DC</p>	 <p>Marker</p>

			
Steel measuring tape	Level	Vacuum cleaner	Hammer drill
			
Hammer drill bit Φ16 mm	Heat shrink tubing	Heat gun	Cable tie
			
Insulated ladder	Crane	Lifting rope Rope length ≥ 1845 mm x 4	Electric forklift
	-	-	-
Pallet truck			

Personal Protective Equipment (PPE)

			
Insulated gloves	Protective gloves	Goggles	Dust mask

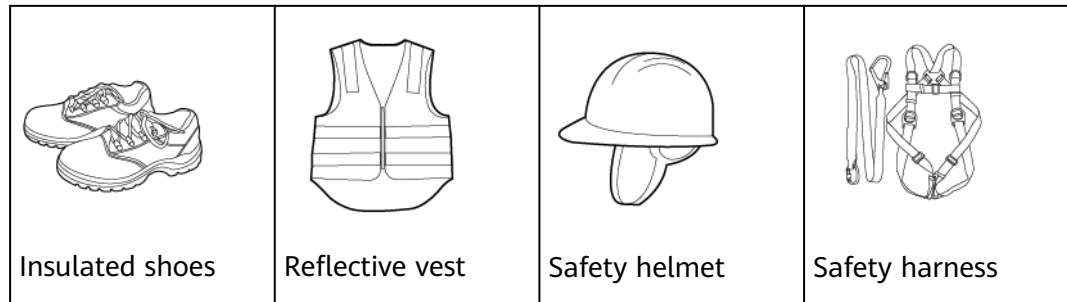

7.1.2 Pre-installation Check

Checking the Outer Packing

Before unpacking the equipment, check the outer packing for damage, such as holes and cracks, and check the equipment model. If any damage is found or the equipment model is not what you requested, do not unpack the product and contact your dealer as soon as possible.

 **NOTE**

You are advised to remove the outer packing within 24 hours before installing the equipment.

 **WARNING**

If the cabinet is higher than 2 m, take protective measures for working at heights during unpacking.

Checking Deliverables

After unpacking the equipment, check that the deliverables are intact and complete, and free from any obvious damage. If any item is missing or damaged, contact your dealer.

 **NOTE**

For details about the number of accessories delivered with the equipment, see the *Packing List* in the packing case.

7.2 Installing the ESS

Step 1 Remove the baffle plate from the bottom of the ESS.

Figure 7-1 Removing the bottom baffle

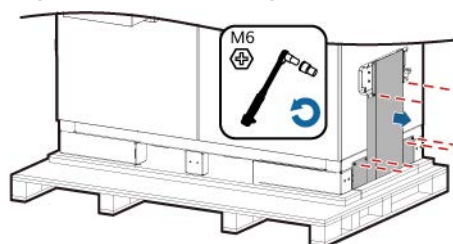

Step 2 Remove the pallets.

Figure 7-2 Removing the pallets

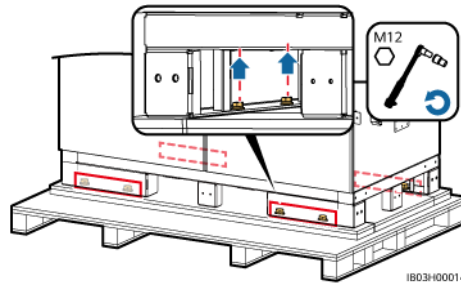

Step 3 Install the baffle plate to the bottom of the ESS.

Figure 7-3 Installing the baffle plate

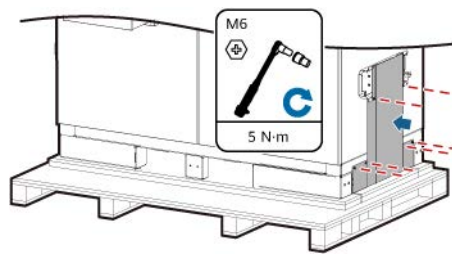

Step 4 Open the cabinet doors.

NOTICE

Do not open the cabinet door when the humidity is high (relative humidity $\geq 80\%$ continuously), for example, on rainy days. If the cabinet door is open for 0.5 hour or longer when the humidity is high, manually perform forced dehumidification in off-grid and on/off-grid scenarios. Otherwise, the equipment may fail or the microgrid may collapse. You can check the running scenario on the SmartLogger WebUI. For details, see [SmartLogger3000 User Manual](#).

Perform dehumidification as follows:

1. Check that the auxiliary AC power supply to the ESS is powered on. In off-grid scenarios, the diesel generator or other external auxiliary power supply is used. In on/off-grid scenarios, the power grid supplies auxiliary power when available.
2. Log in to the SmartLogger WebUI and choose **Monitoring > ESS > CMU > Running Param.**
3. Choose **Temper And Hum > Control mode**, set **Control mode** to **Manual**, and submit the settings.
4. Click **Starting up** and confirm the operation to start forced dehumidification. View the alarm information to check that the system has started forced dehumidification. The alarm will be automatically cleared after the dehumidification is complete, which takes about 10 to 20 minutes.

 NOTE

Keep the keys properly after use.

Figure 7-4 Opening the doors

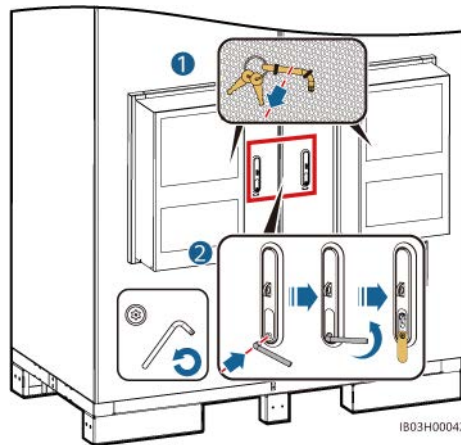

Step 5 Take out the delivered documents, such as the packing list.

Figure 7-5 Document position

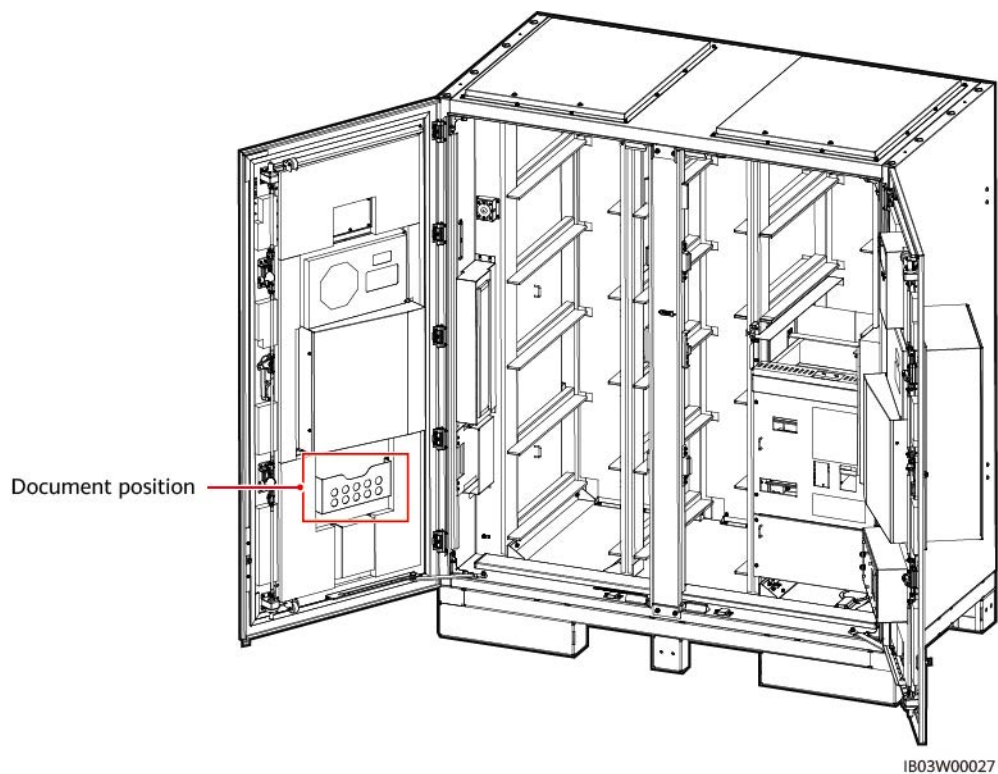





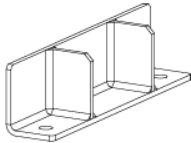

Step 6 Take out the mounting kits delivered with the product.

 NOTE

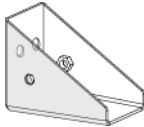
After opening the door, check the number of deliverables based on the packing list. If any deliverable is missing, contact your dealer immediately.

Table 7-1 List of mounting kits

Hoisting conversion bracket and screw		Anchor bracket, anchor bracket screw, and expansion bolt			Leveling spacer
					

Step 7 After closing the cabinet doors, move the ESS to the specified position.

 **NOTE**

If a forklift cannot be used on the transport route (for example, there is a slope), use a crane to move the ESS.

Figure 7-6 Using a crane

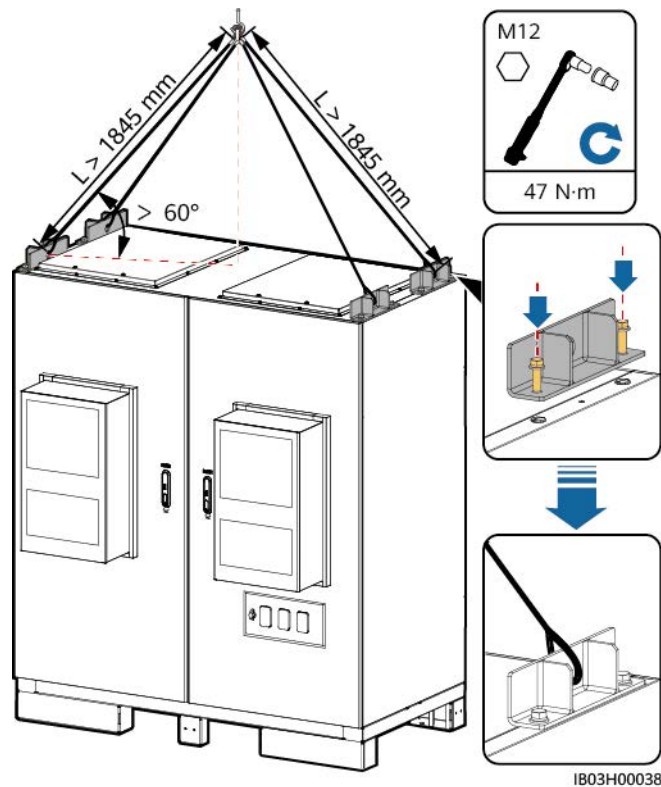
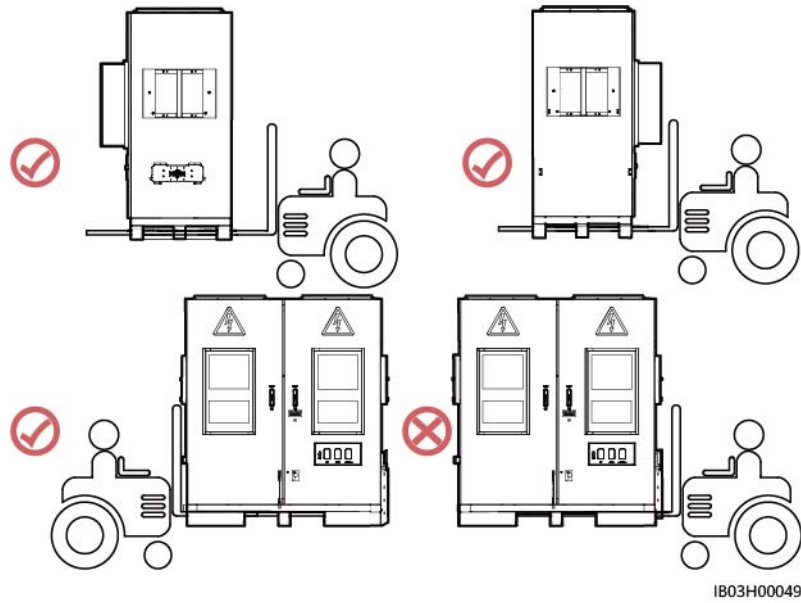

Figure 7-7 Using a forklift

NOTICE

When a forklift is used, bind and secure the ESS based on the site requirements to ensure there is no risk of falling.



IB03H00049

Step 8 Secure the ESS.

NOTE

If the ESS is not positioned stably, use a spacer to level the ESS before securing it.

Figure 7-8 Securing the ESS

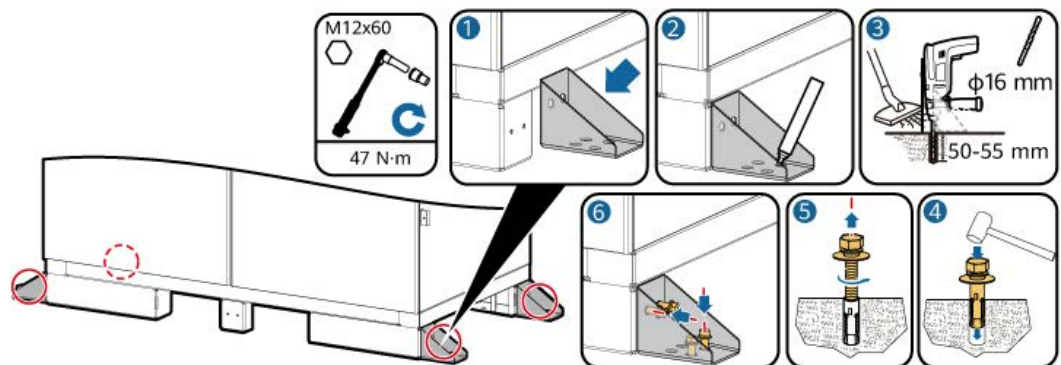

----End

7.3 Connecting a Ground Cable for the ESS

NOTE

Ensure that the grounding impedance of the equipment complies with GB 50054 and local electrical standards.

7.3.1 Inside the Cabinet

Prerequisites

For details about how to crimp OT/DT terminals, see [A Crimping an OT or DT Terminal](#).

Name	Type	Conductor Cross-Sectional Area	Outer Diameter	Terminal	Source
Ground cable	Single-core outdoor copper/ copper-clad aluminum/ aluminum alloy cable	25–50 mm ²	15–17.6 mm	M8 OT/DT terminal	Prepared by the customer

The specifications of the ground cable are subject to this table or calculated according to IEC 60364-5-54.

Procedure

Step 1 Open the ESS cabinet doors.

Step 2 Connect the ground cable.

Figure 7-9 Connecting a ground cable

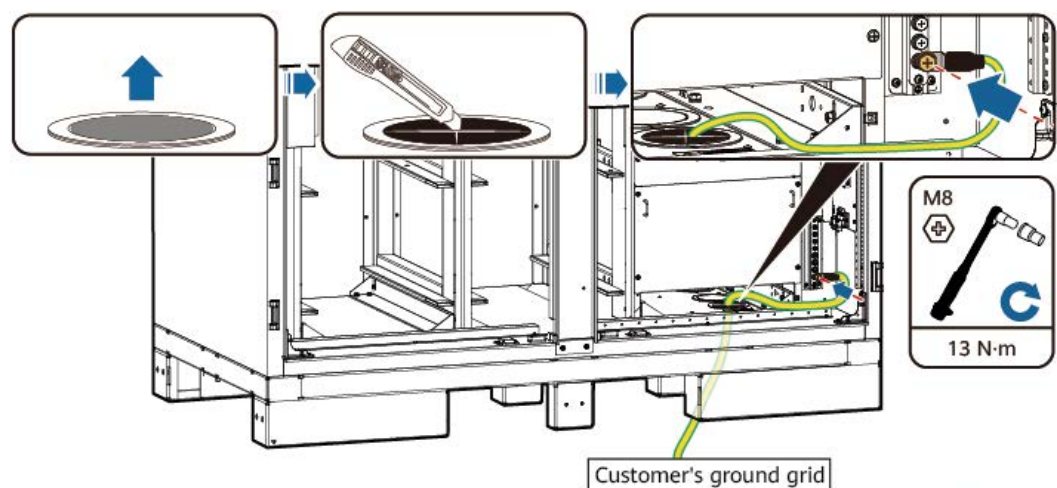

IB03I50001

----End

7.3.2 (Optional) Outside the Cabinet

Using a Flat Steel Sheet

The hot-dip zinc-coated flat steel sheet needs to be prepared by the customer (recommended specification: $\geq -40 \times 4$). The specific dimensions depend on the onsite fault current and are subject to the design of the design institute.

Figure 7-10 Connecting a ground flat steel sheet

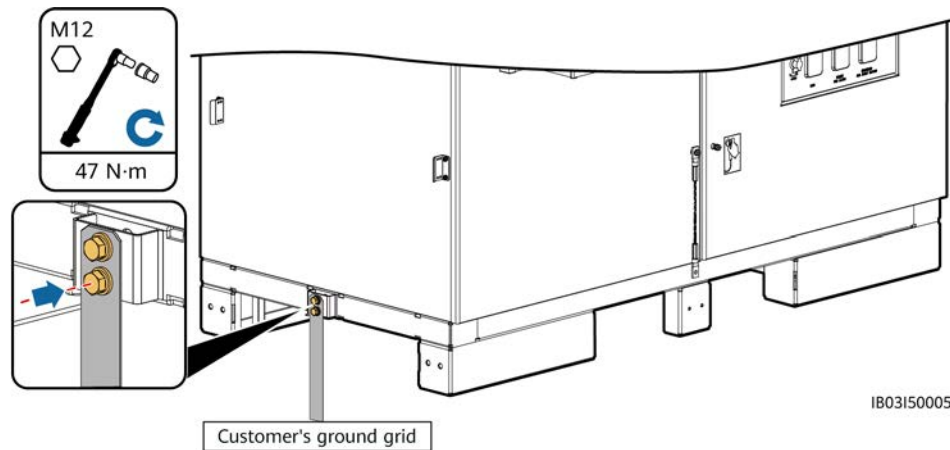

IB03150005

Using a Ground Cable

For details about how to crimp OT/DT terminals, see [A Crimping an OT or DT Terminal](#).

Name	Type	Conductor Cross-Sectional Area	Outer Diameter	Terminal	Source
Ground cable	Single-core outdoor copper/ copper-clad aluminum/ aluminum alloy cable	25–50 mm ²	15–17.6 mm	M12 OT/DT terminal	Prepared by the customer

The specifications of the ground cable are subject to this table or calculated according to IEC 60364-5-54.

Figure 7-11 Connecting a ground cable

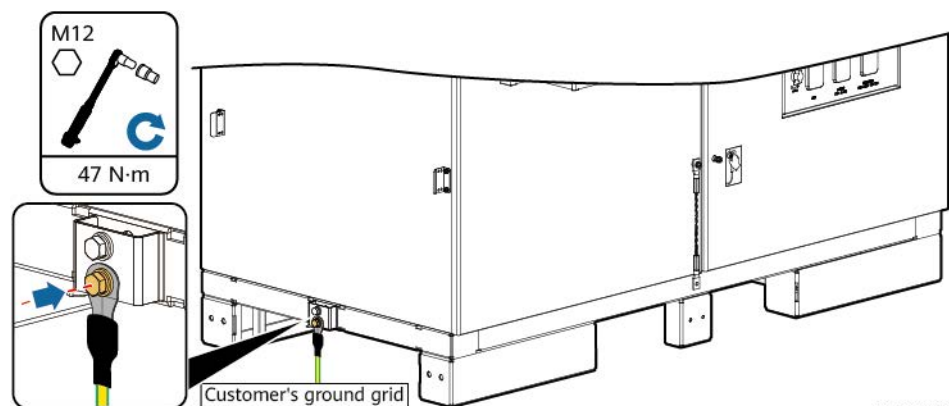

IB03150006

7.4 Installing Components

Table 7-2 Component installation list

Component	Installation Position	Quantity
Rack mounted fire extinguishing system	Above the power distribution area in the ESS	1
Battery pack	Battery guide rails in the ESS	6/8/10/12 ^[1]
Rack controller	Right side of the ESS	1
Smart PCS	Left side of the ESS	1
(Optional) Maintenance socket	Power distribution area in the ESS	1
(Optional) Smart Power Sensor (DDSU666-H)	Power distribution area in the ESS	1
Note [1]: <ul style="list-style-type: none">• Six dummy battery packs are preinstalled in the LUNA2000-97KWH-1H1 ESS, in which six battery packs are required.• Four dummy battery packs are preinstalled in the LUNA2000-129KWH-2H1 ESS, in which eight battery packs are required.• Two dummy battery packs are preinstalled in the LUNA2000-161KWH-2H1 ESS, in which ten battery packs are required.• Twelve battery packs are required in the LUNA2000-200KWH-2H1 ESS.		

NOTICE

Before installing components, ensure that the ESS is securely installed.

Table 7-3 Battery pack configuration

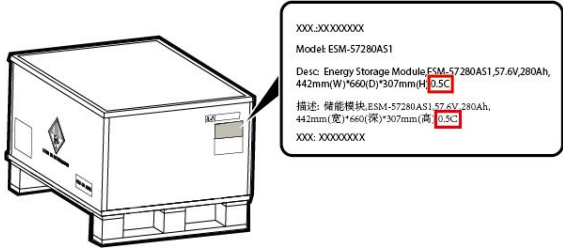
ESS	Battery Pack Model	Remarks
LUNA2000-20 0KWH-2H1	ESM51320AS 1 (320 Ah, 1C)	<p>The battery packs in an ESS must be of the same model and charge and discharge rate, and the model of the battery packs must match that of the ESS. Otherwise, the ESS cannot run properly.</p> <p>The ESM57280AS1 model includes two types of battery packs: 0.5C and 1C, which can be distinguished by the battery pack label.</p> 
	ESM57280AS 1 (280 Ah, 0.5C)	
LUNA2000-16 1KWH-2H1	ESM57280AS 1 (280 Ah, 1C)	
LUNA2000-12 9KWH-2H1		
LUNA2000-97 KWH-1H1		

7.4.1 Installing the Rack Mounted Fire Extinguishing System

Prerequisites

- Ensure that the rack mounted fire extinguishing system is intact.
- Before installation, read the documents delivered with the rack mounted fire extinguishing system to understand the installation requirements and precautions.

Procedure

Install the rack mounted fire extinguishing system.

Figure 7-12 Installing the rack mounted fire extinguishing system

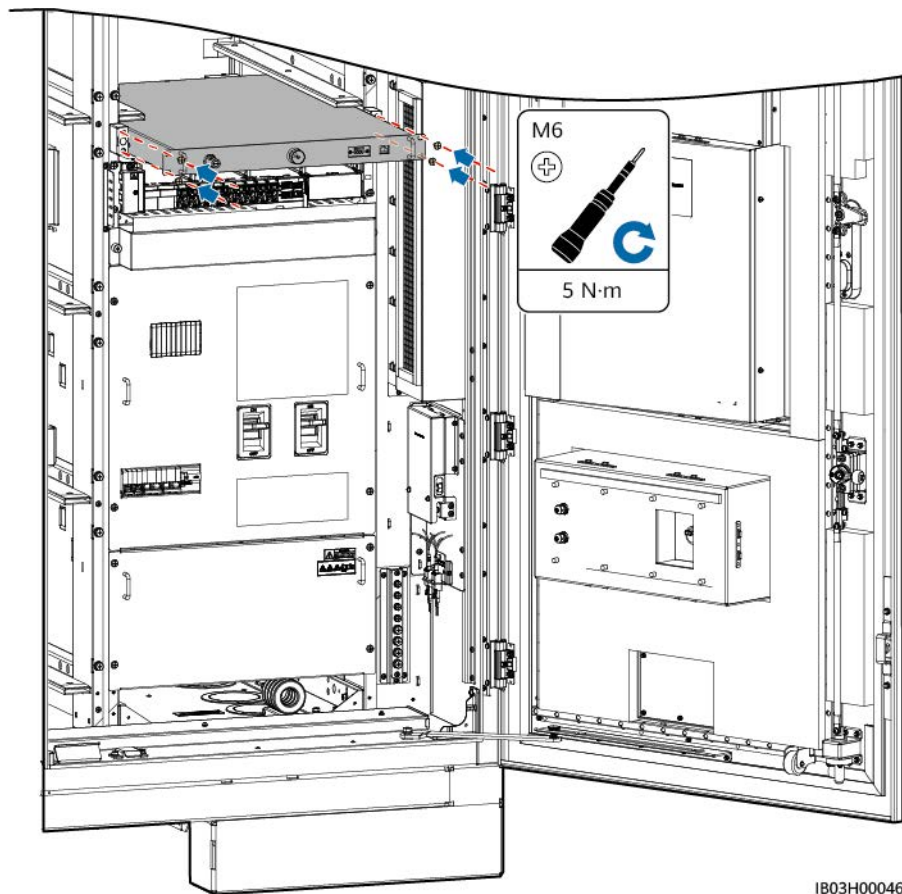

7.4.2 Installing Battery Packs

7.4.2.1 Installation Kit

WARNING

- Do not stand under the installation kit.
 - Do not put your head, hands, feet, or other body parts under the installation kit.
-

CAUTION

- Multiple persons are required in the operation. Take protective measures to prevent collision.
 - When working at heights is involved, see the relevant safety precautions.
-

NOTICE

- Do not use the installation kit on rainy days. Dry the installation kit if it comes in contact with water to prevent rusting.
- Place the installation kit in the packing case after use and store it in a dry place indoors.
- If rust occurs on the parts, remove the rust immediately and apply lubricating oil.

Ball Transfer Platform

Figure 7-13 Components

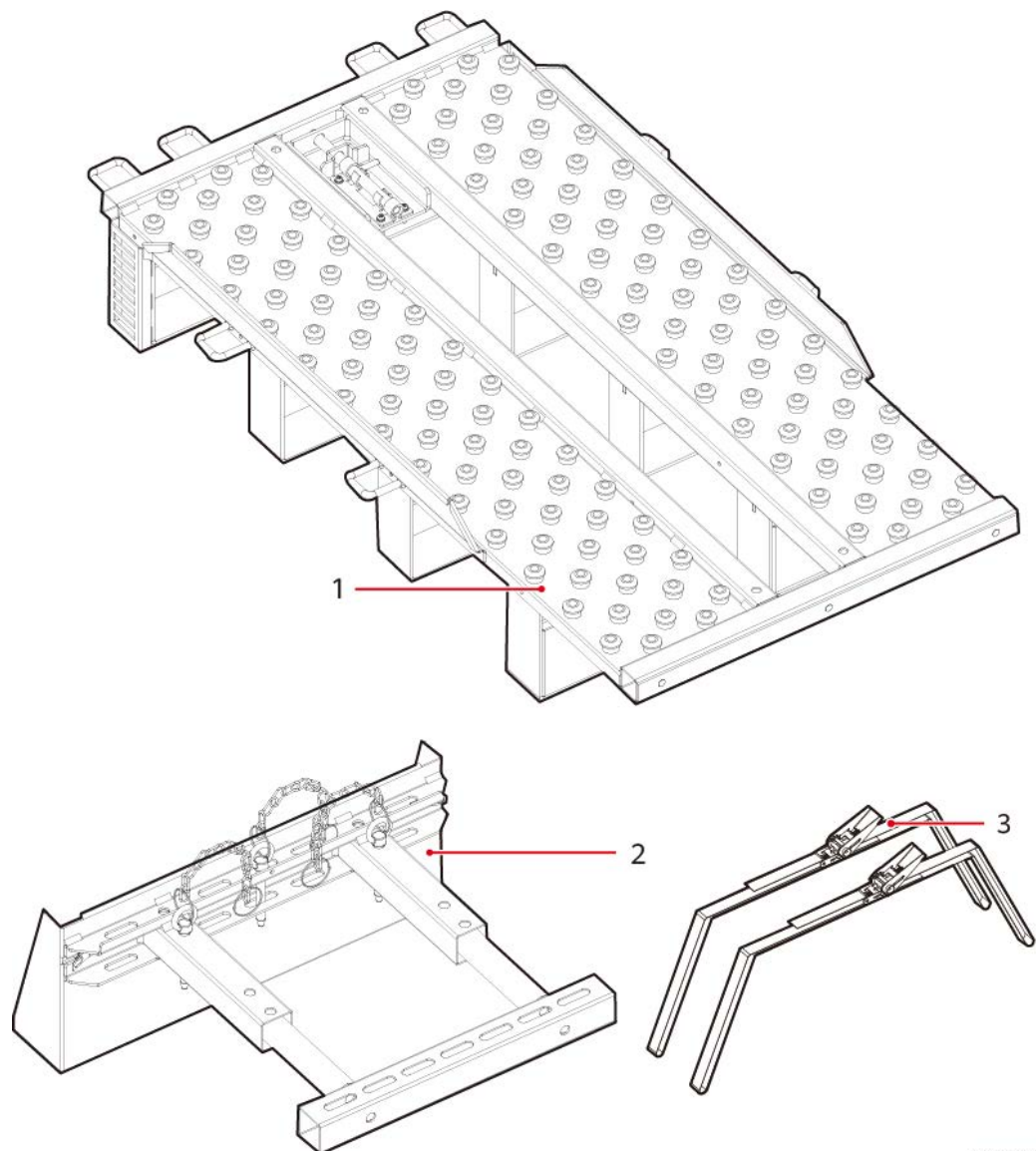

IB03H00060

- (1) Installation kit components (2) Battery pack operating handle (3) Binders

Sliding Rack Shelf

Figure 7-14 Components

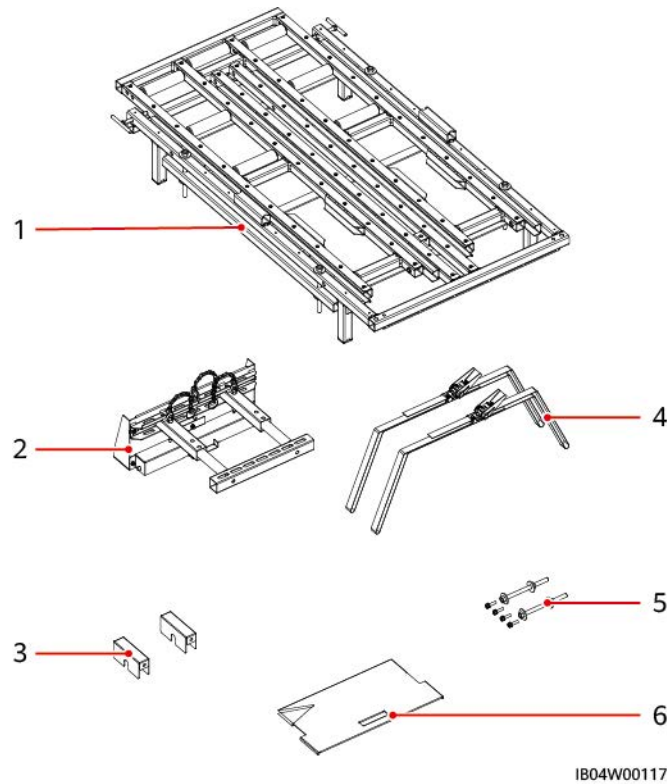

- (1) Installation kit components (2) Battery pack shovel pan (3) Distance blocks
(4) Binders (5) Screws (6) Protective plate

7.4.2.2 Installing Battery Packs (Using a Ball Transfer Platform)

Context

- You are advised to use a forklift and battery installation tray kit (installation kit for short) to install battery packs. The installation kit is not delivered with the product and needs to be purchased separately from the Company.
- The appearance of the installation kit in this document is for reference only.

 **WARNING**

- Ensure that the power circuit breaker is OFF before installing batteries.
 - When installing batteries, do not place installation tools, metal parts, or sundries on the batteries. After the installation is complete, clean up the objects on the batteries and the surrounding area.
 - When moving batteries, do not remove protective components such as protective covers or waterproof caps from battery terminals.
 - Do not move or operate under the forklift tynes.
 - You can operate the battery pack installation kit only after the forklift stops moving.
-

 **CAUTION**

- Slowly push or move battery packs to prevent damage and collision.
 - To prevent battery packs from falling off, start the pallet truck or forklift after confirming that battery packs are securely bound.
-

NOTICE

- Before installation, ensure that battery packs are stored indoors and that other storage requirements specified in the user manual are met.
 - Before installation, check the status of the battery packs. Do not use the battery packs if the packing cases are exposed to rain, damaged, or deformed, or if the battery packs leak or fall.
 - Install batteries within 24 hours after unpacking. If the batteries cannot be installed in time, put them in the original packaging and place them in a dry indoor environment without corrosive gases. Power on the ESS within 24 hours after installation. The process from unpacking batteries to powering on the system must be completed within 72 hours. During routine maintenance, ensure that the power-off time does not exceed 24 hours.
 - Do not install battery packs on rainy, snowy, or foggy days. Otherwise, the battery packs may be corroded by moisture or rain.
-

Procedure

- Step 1** Remove the column in the middle.

Figure 7-15 Removing the column

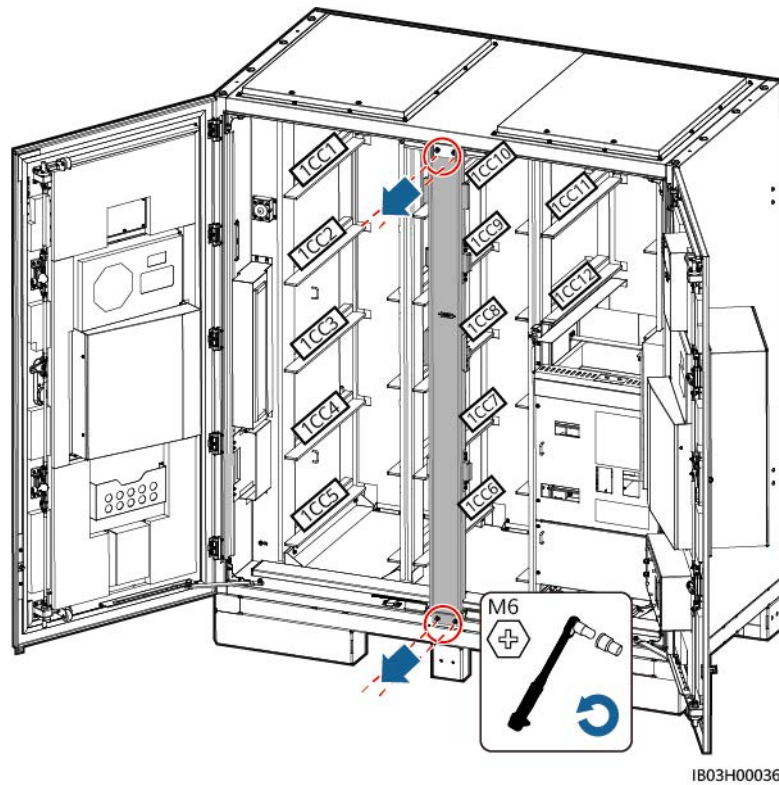

Step 2 Use a forklift to transport the installation kit to the vicinity of the ESS.

Step 3 Take out the installation kit.

Figure 7-16 Taking out the installation kit

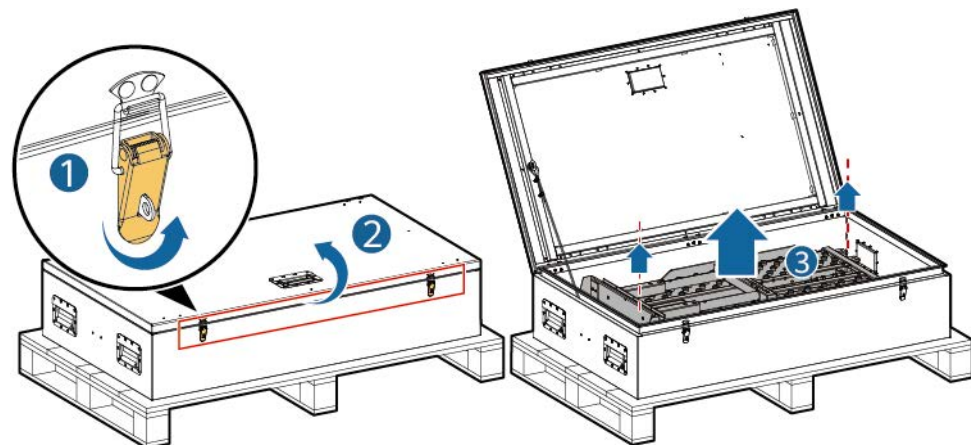

Step 4 Insert, assemble, and secure the installation kit onto the forklift.

Figure 7-17 Assembling the installation kit

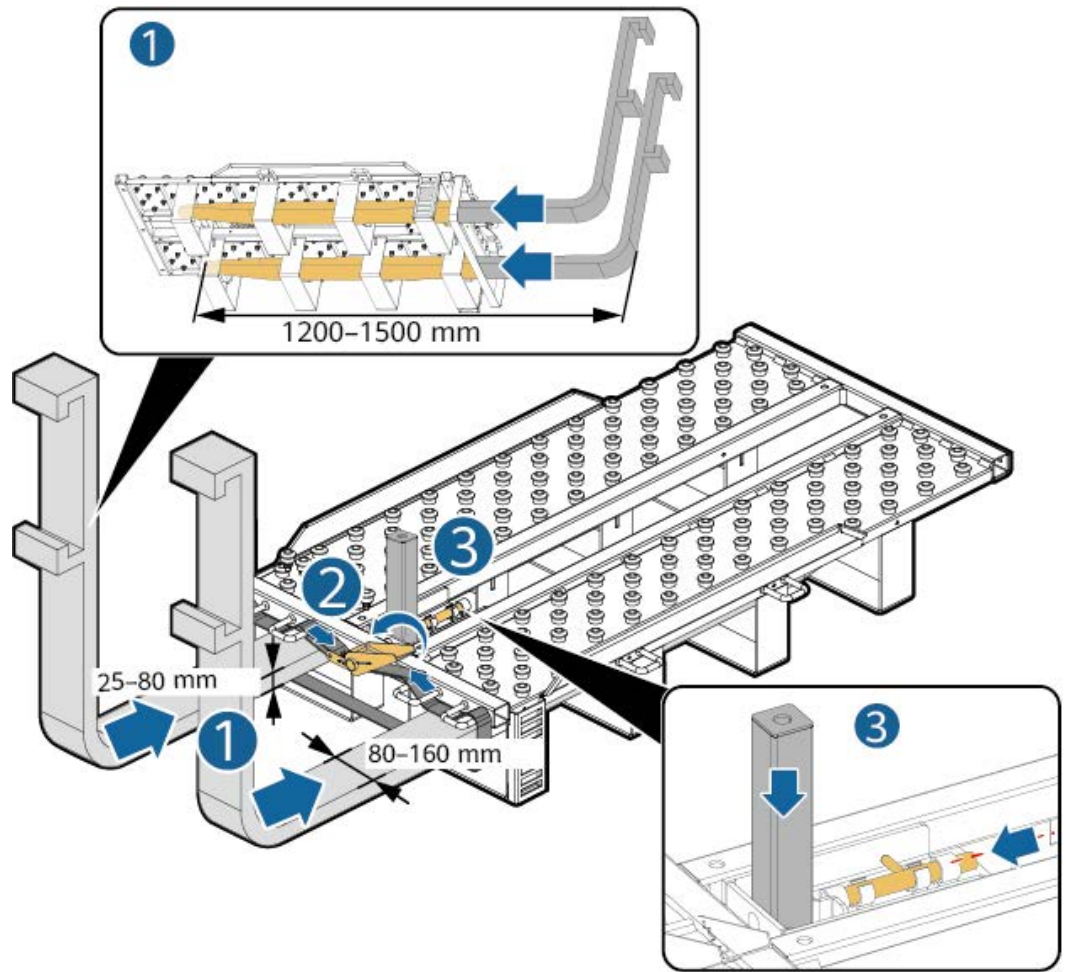

Step 5 Take out a battery pack.

NOTE

- At least four persons are required to move a battery pack.
- Secure the lifting handles (with the steel washers of the lifting handles closely fitted to the battery pack).
- If the stud of a lifting handle is bent, replace the lifting handle in time.
- When using the lifting handles delivered with the product, hold the end closer to the device.

Figure 7-18 Taking out the battery pack

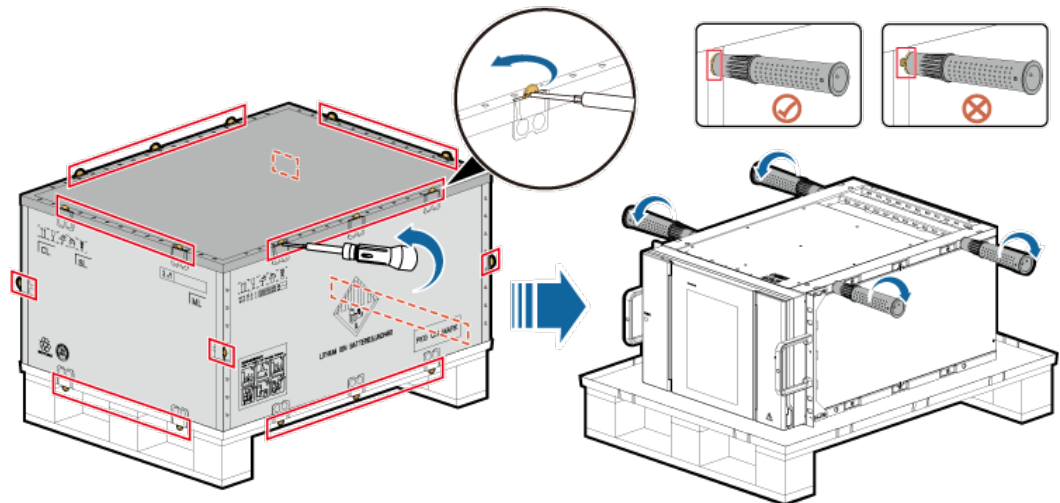

Step 6 Install the operating handle on the battery pack, place the battery pack on the installation kit, and secure the battery pack.

Figure 7-19 Securing the battery pack

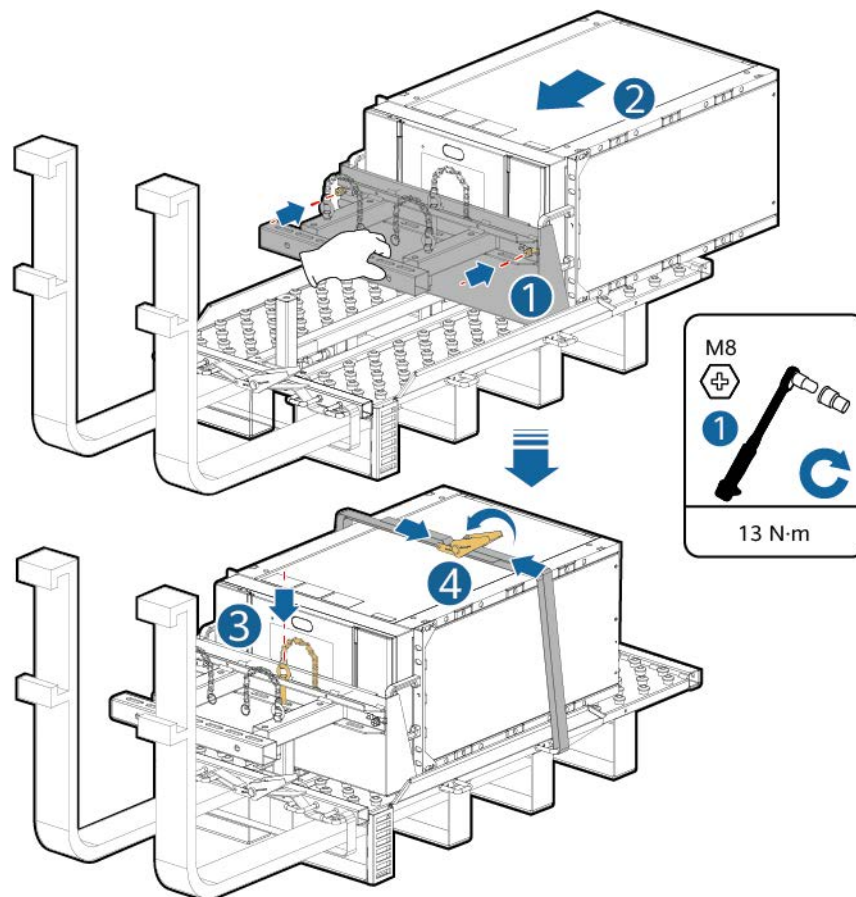

Step 7 Install the battery pack in the ESS.

 NOTE

Dummy battery packs have been preinstalled in the 97 kWh, 129 kWh, and 161 kWh ESSs to separate air channels and must not be removed.

Figure 7-20 Installing the battery pack in the ESS

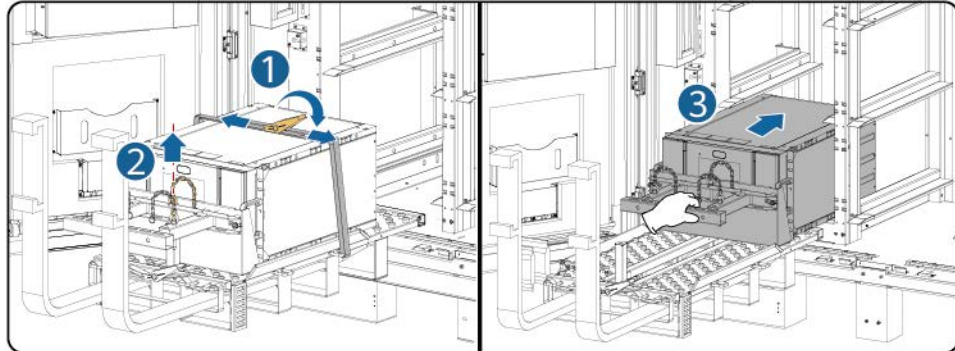

IB03H00025

Step 8 Secure the battery pack.

Figure 7-21 Securing the battery pack

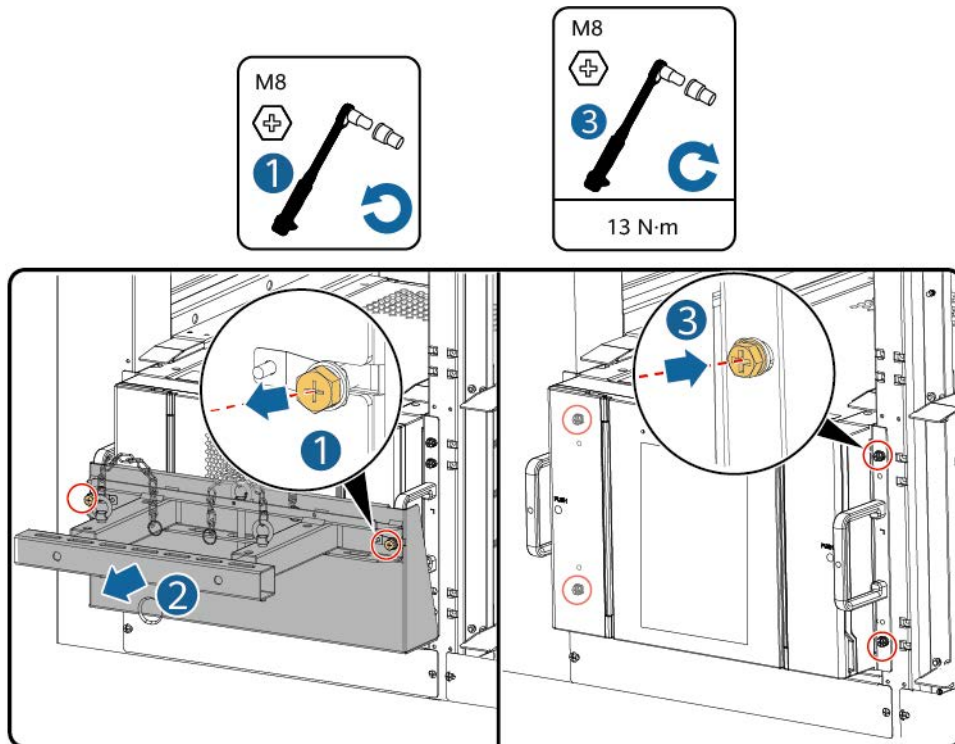

IB03H00026

Step 9 Install air channel plates between battery packs based on the label on the air channel plates. The air channel plates are delivered with the product.

Figure 7-22 Installing air channel plates

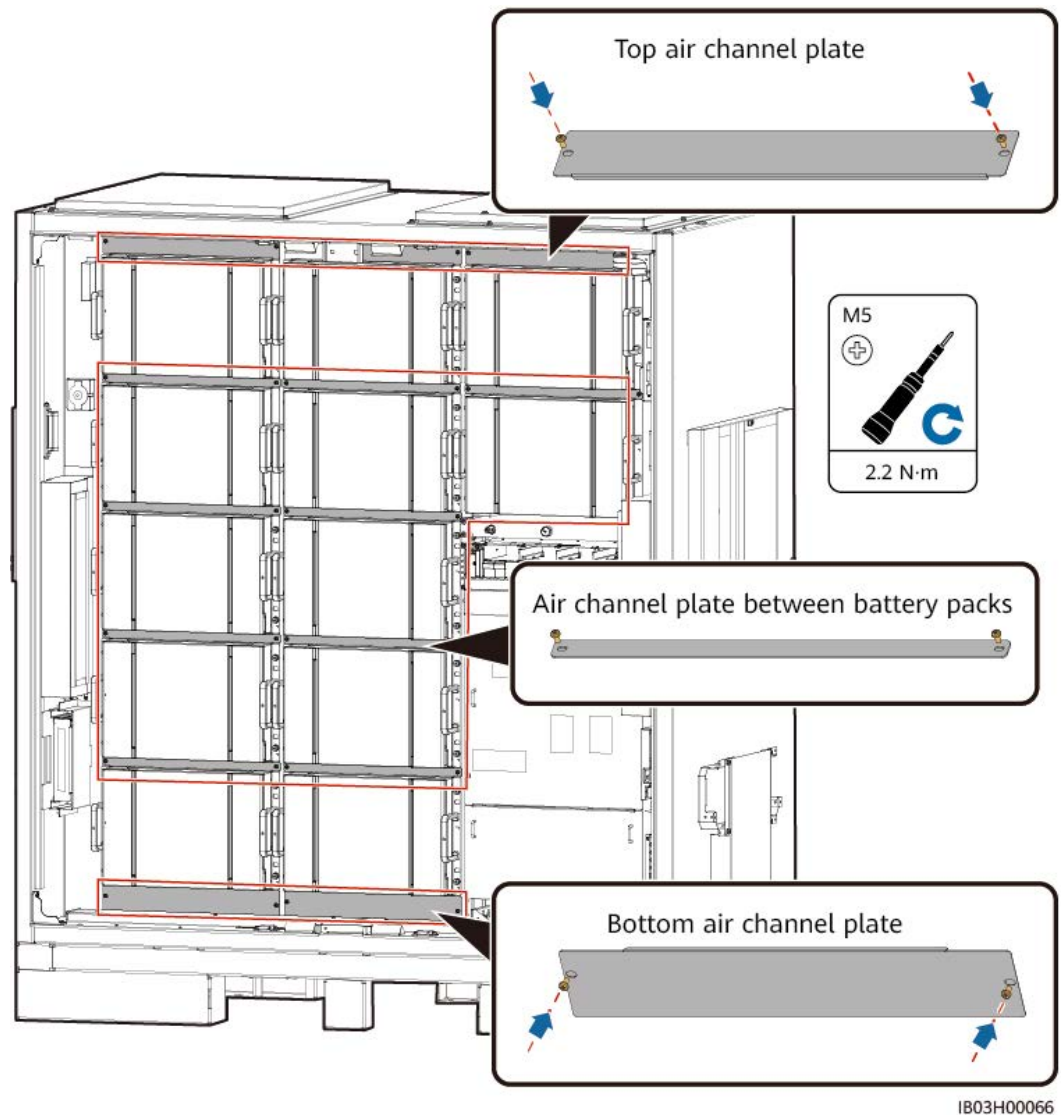

Step 10 Install the column to the ESS.

Figure 7-23 Installing the column

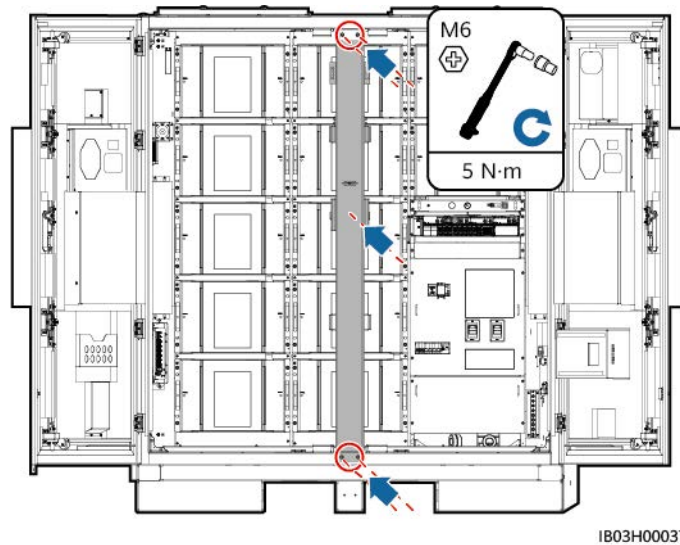

----End

Follow-up Procedure

Place the installation kit in the packing case after use and store it in a dry place indoors.

7.4.2.3 Installing Battery Packs (Using a Sliding Rack Shelf)

Context

- You are advised to use a forklift and battery installation tray kit (installation kit for short) to install battery packs. The installation kit is not delivered with the product and needs to be purchased separately from the Company.
- The appearance of the installation kit in this document is for reference only.

WARNING

- Ensure that the power circuit breaker is OFF before installing batteries.
 - When installing batteries, do not place installation tools, metal parts, or sundries on the batteries. After the installation is complete, clean up the objects on the batteries and the surrounding area.
 - When moving batteries, do not remove protective components such as protective covers or waterproof caps from battery terminals.
 - Do not move or operate under the forklift tynes.
 - You can operate the battery pack installation kit only after the forklift stops moving.
-

 **CAUTION**

- Slowly push or move battery packs to prevent damage and collision.
 - To prevent battery packs from falling off, start the pallet truck or forklift after confirming that battery packs are securely bound.
-

NOTICE

- Before installation, ensure that battery packs are stored indoors and that other storage requirements specified in the user manual are met.
 - Before installation, check the status of the battery packs. Do not use the battery packs if the packing cases are exposed to rain, damaged, or deformed, or if the battery packs leak or fall.
 - Install batteries within 24 hours after unpacking. If the batteries cannot be installed in time, put them in the original packaging and place them in a dry indoor environment without corrosive gases. Power on the ESS within 24 hours after installation. The process from unpacking batteries to powering on the system must be completed within 72 hours. During routine maintenance, ensure that the power-off time does not exceed 24 hours.
 - Do not install battery packs on rainy, snowy, or foggy days. Otherwise, the battery packs may be corroded by moisture or rain.
-

Procedure

- Step 1** Remove the column from the ESS.

Figure 7-24 Removing the column

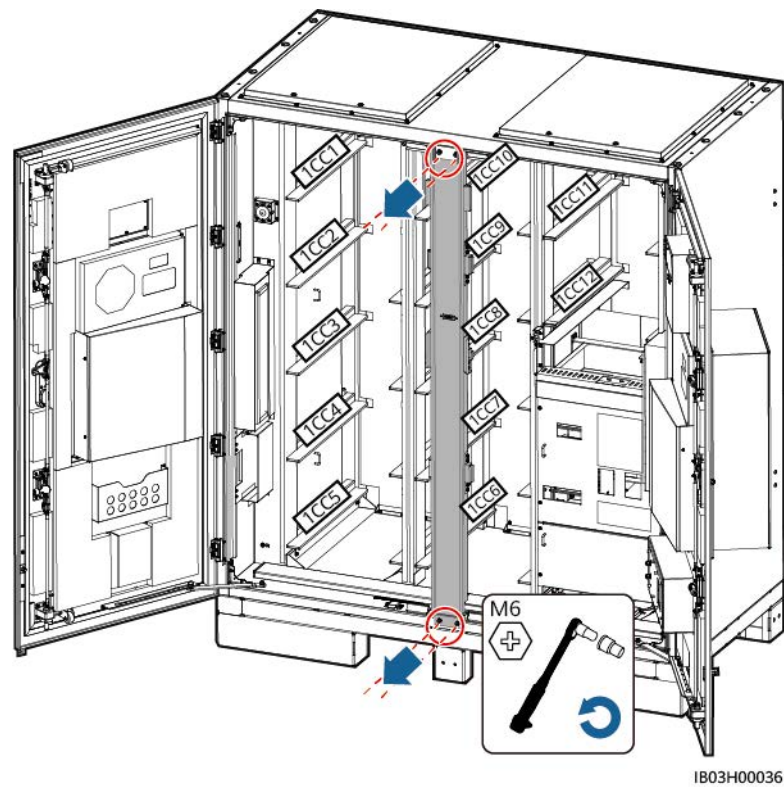

Step 2 Take out the installation kit.

Figure 7-25 Taking out the installation kit

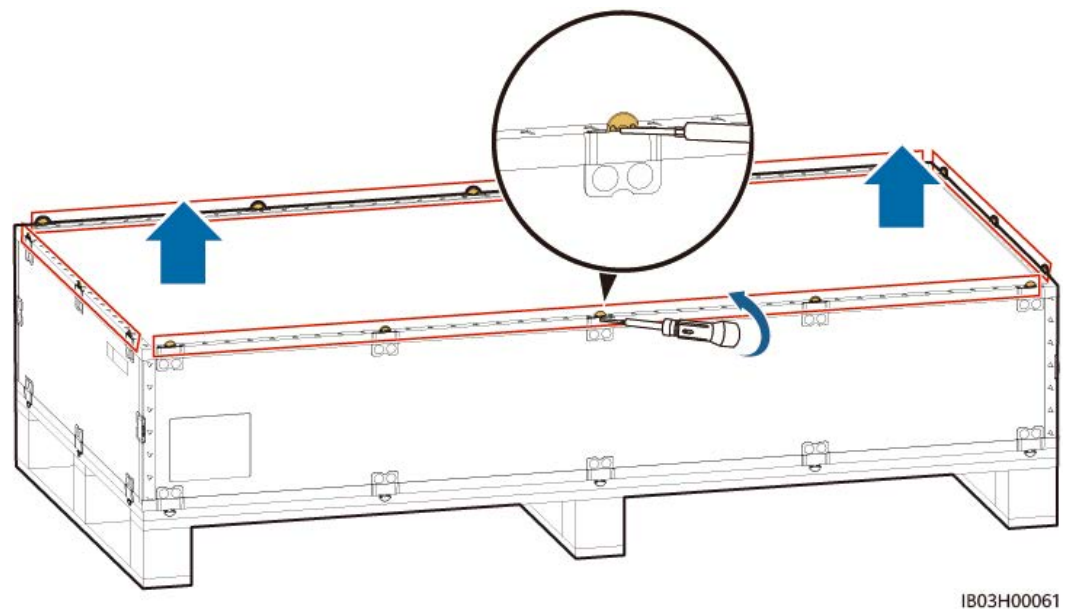

Step 3 Insert, assemble, and secure the installation kit onto the forklift: Tighten the four screws and two handles.

Figure 7-26 Assembling the installation kit

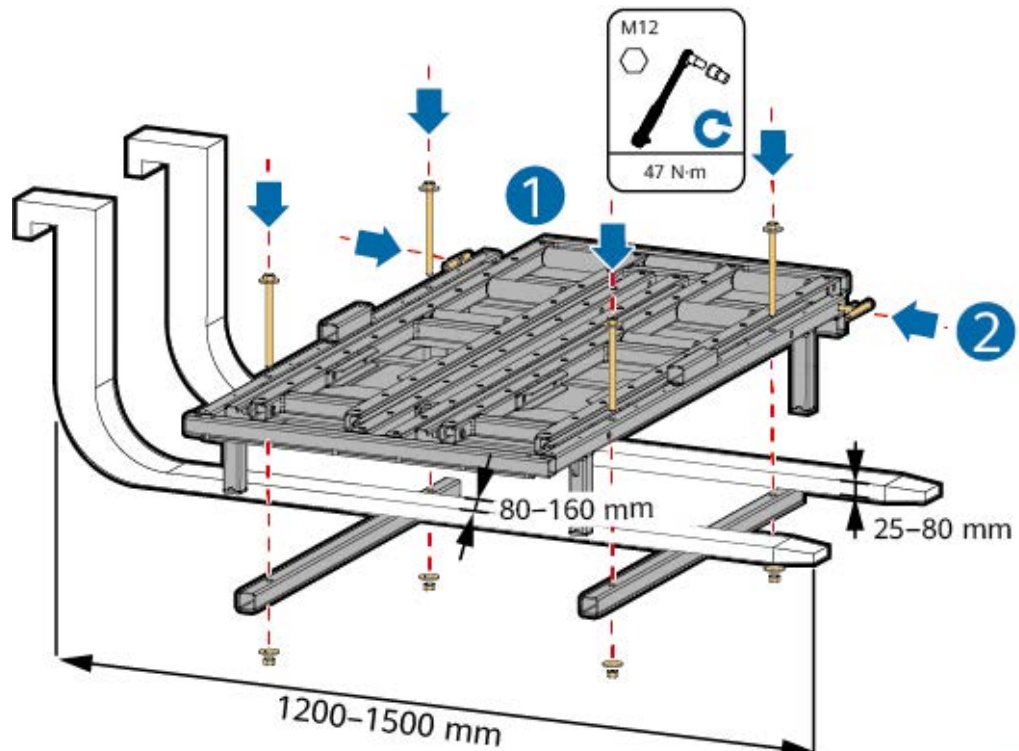

IB03H00062

Step 4 (Optional) Install the protective plate.

NOTE

When installing a battery pack at the bottom, you do not need to install a protective plate.

Step 5 Take out the battery pack and install the lifting handles.

NOTE

- At least four persons are required to move a battery pack.
- Secure the lifting handles (with the steel washers of the lifting handles closely fitted to the battery pack).
- If the stud of a lifting handle is bent, replace the lifting handle in time.
- When using the lifting handles delivered with the product, hold the end closer to the device.

Figure 7-27 Taking out the battery pack

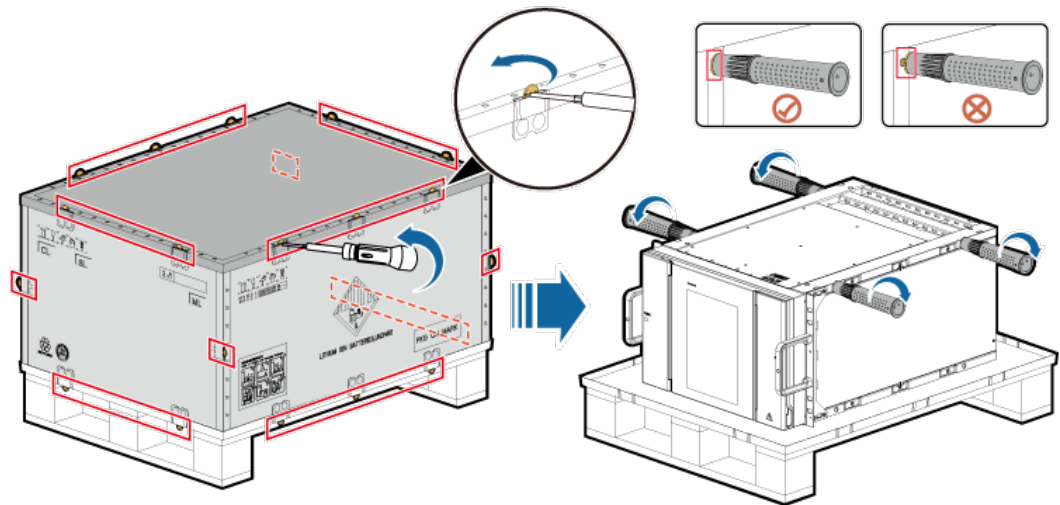

IB03H00031

Step 6 Move the battery pack onto the kit base, and remove the lifting handles.

Figure 7-28 Moving the battery pack

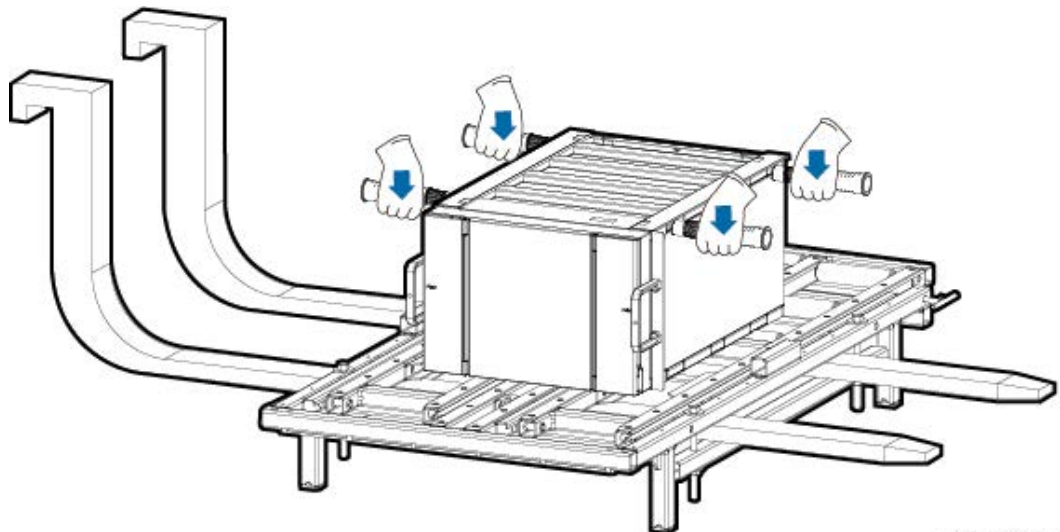

IB04H00187

Step 7 Install the shovel pan, positioning pin, and binding straps.

Figure 7-29 Securing the battery pack

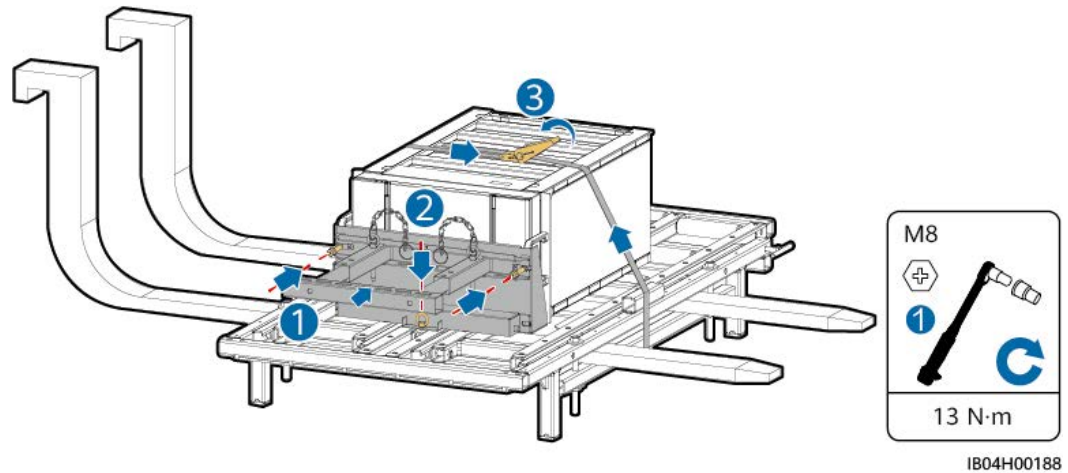

Step 8 Move the forklift to the vicinity of the ESS, adjust the height of the installation kit, and remove the battery pack straps.

NOTE

Align the height of the installation kit with the battery pack slot rails.

Step 9 Pull out the kit drawer: Loosen the two handles, pull out the drawer, and tighten the two handles. Then, install the distance blocks.

NOTICE

- The kit drawer shall be flush with the protective plate.
- Determine the number of distance blocks and their positions based on the actual application scenario.

Step 10 Remove the battery pack positioning pin and pull the battery pack onto the kit drawer.

Figure 7-30 Pulling out the kit drawer

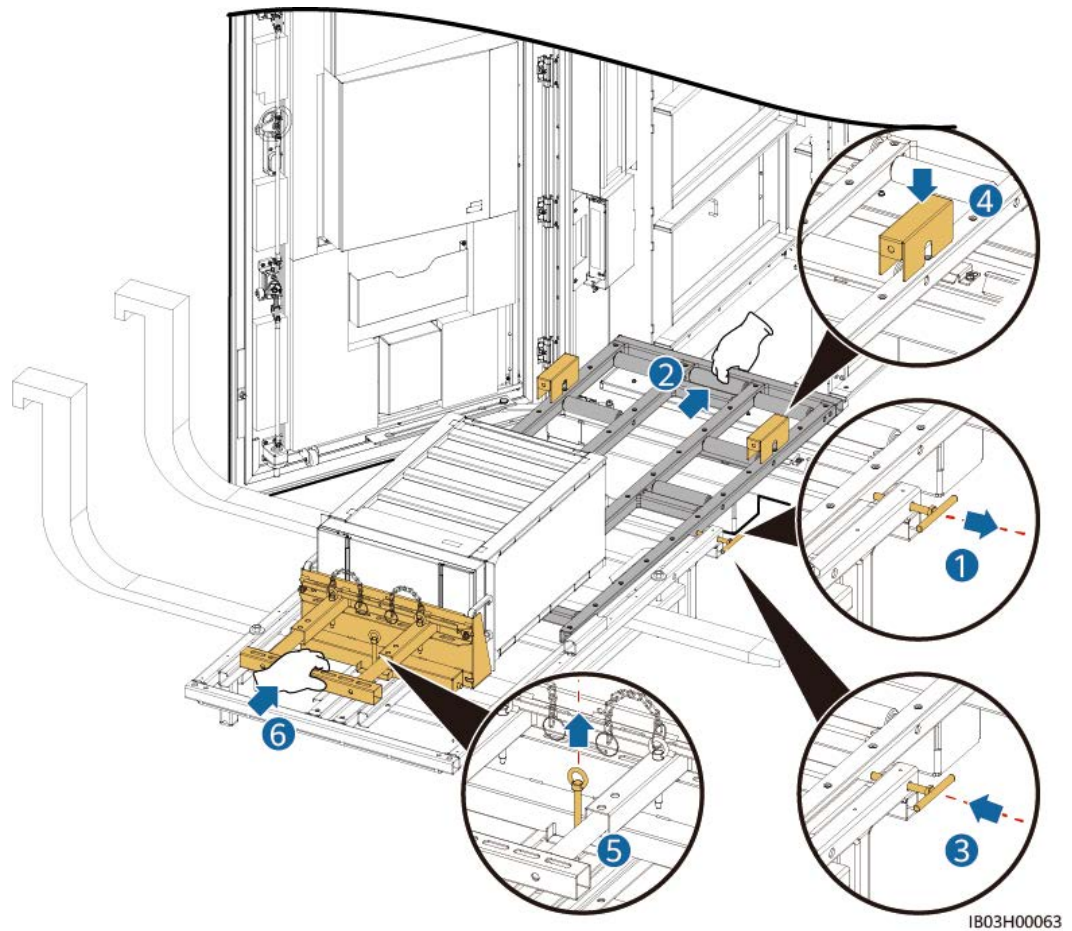

Step 11 Move the battery pack into the installation slot.

NOTE

Dummy battery packs have been preinstalled in the 97 kWh, 129 kWh, and 161 kWh ESSs to separate air channels and must not be removed.

Step 12 Remove the distance blocks, and push in the kit drawer: Loosen the two handles, push in the drawer, and tighten the two handles.

Figure 7-31 Pushing in the kit drawer

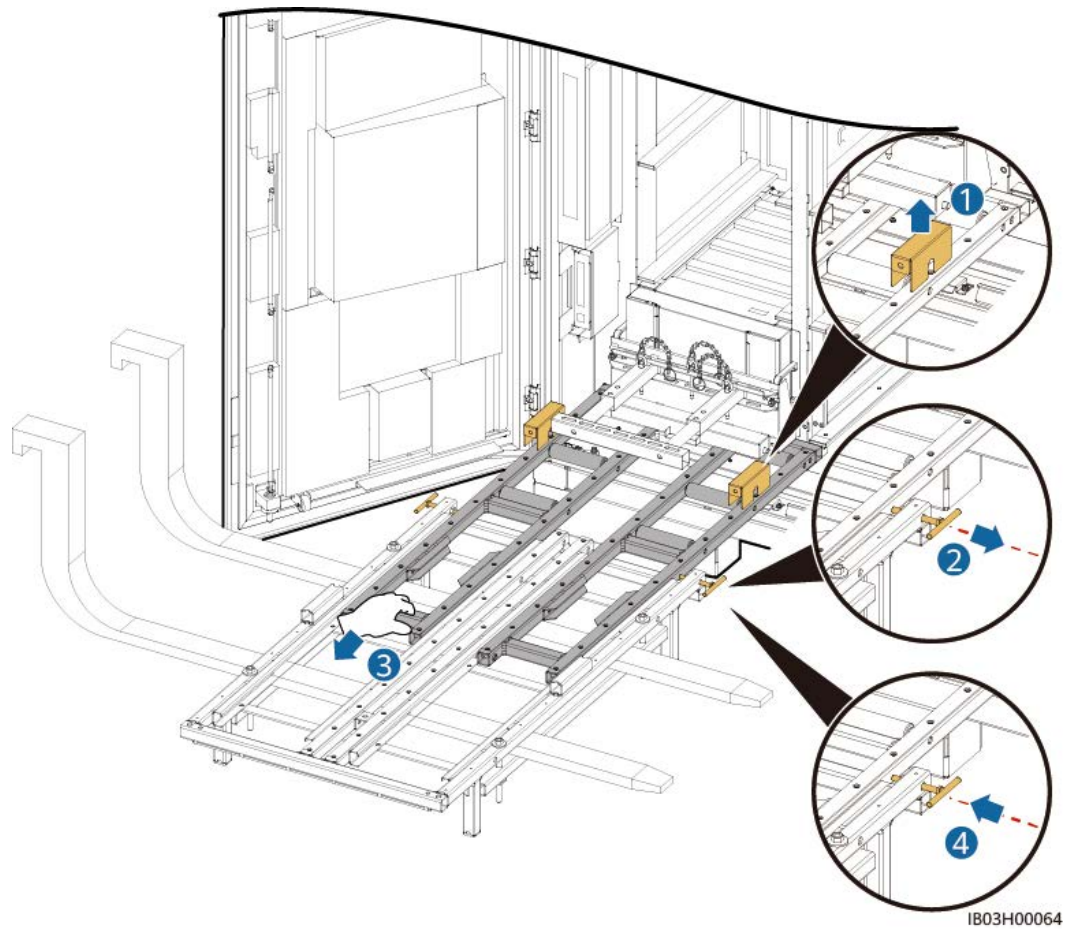

Step 13 Lower the installation kit and remove the forklift.

Step 14 (Optional) Remove the protective plate.

Step 15 Remove the shovel pan and secure the battery pack.

Figure 7-32 Securing the battery pack

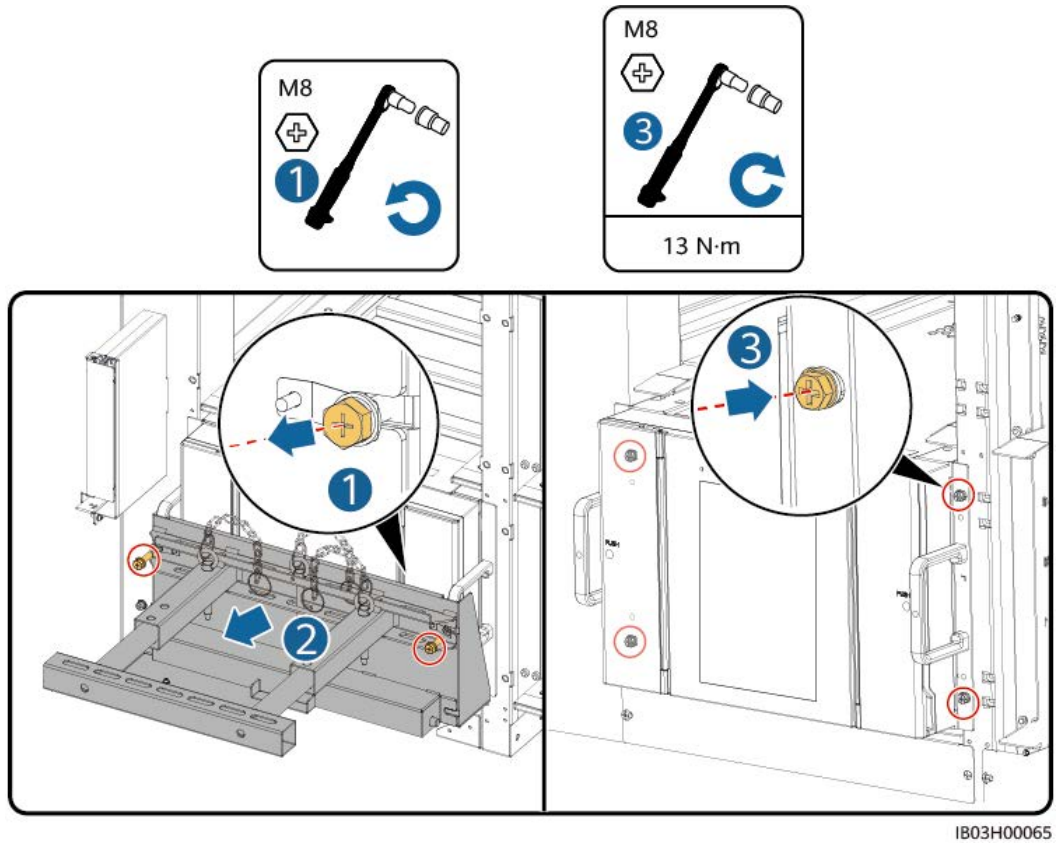

Step 16 Install air channel plates between battery packs based on the label on the air channel plates. The air channel plates are delivered with the product.

Figure 7-33 Installing air channel plates

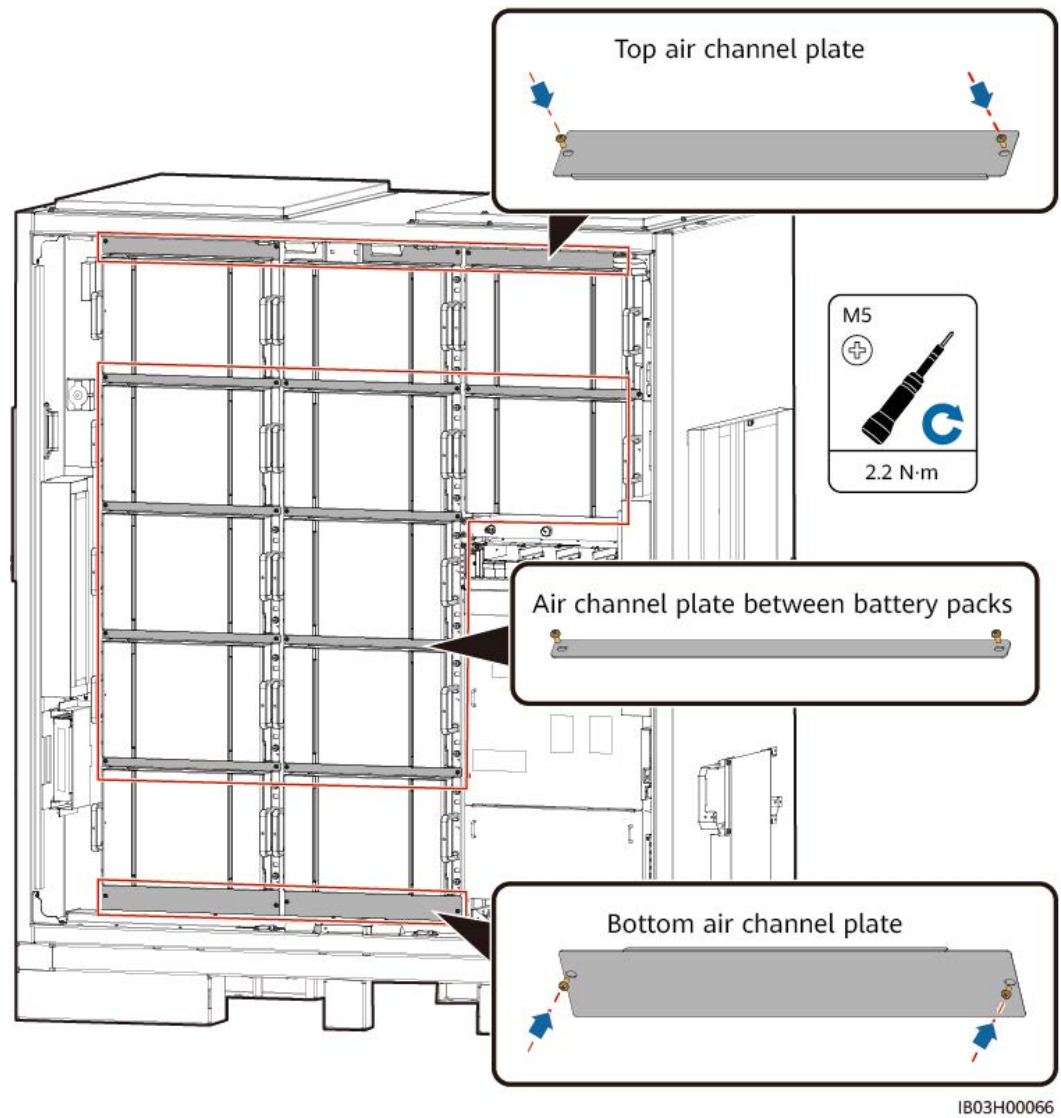

Step 17 Install the column to the ESS.

Figure 7-34 Installing the column

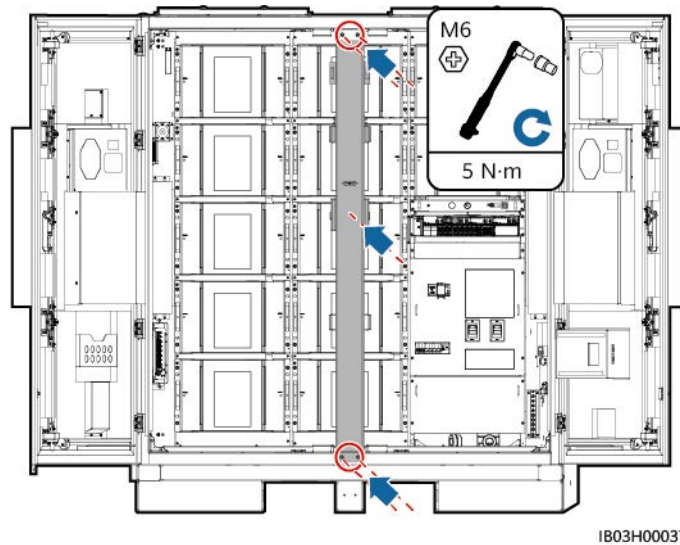

----End

Follow-up Procedure

Place the installation kit in the packing case after use and store it in a dry place indoors.

7.4.3 Installing the Smart Rack Controller

Prerequisites

Unpack and check the rack controller delivered to the site to ensure that it is intact.

Procedure

NOTE

If you do not install the rack controller cables immediately, you are advised to install the short-circuiting copper bars on the rack controller by referring to steps 1 to 3. If you install the rack controller cables immediately, perform steps 1 to 3 together with the procedure in [8.4 Installing Rack Controller Cables](#).

Step 1 Remove the decorative cover and maintenance compartment cover from the rack controller.

Figure 7-35 Removing covers

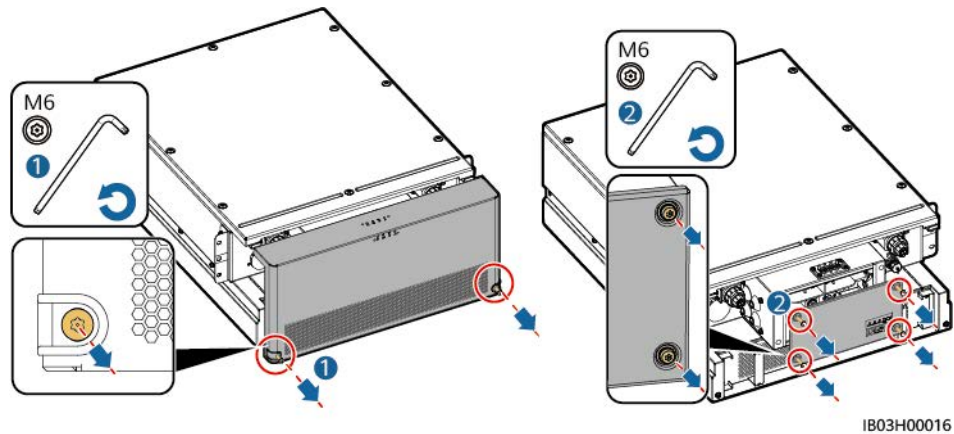

Step 2 Install short-circuiting copper bars that are delivered with the product.

NOTE

- When installing a nut, manually insert the nut into the screw plate, and then use a socket wrench to completely secure the nut in place. This prevents the screw thread from being stuck or stripped due to the deviation of the nut position.
- Preinstall nuts according to the recommended torque of 21 N·m.
- Verify the torque of the installed nuts using a torque socket wrench set to 21 N·m.
- Mark the nuts whose torque has been verified using a marker.

Figure 7-36 Installing short-circuiting copper bars (200 kWh model)

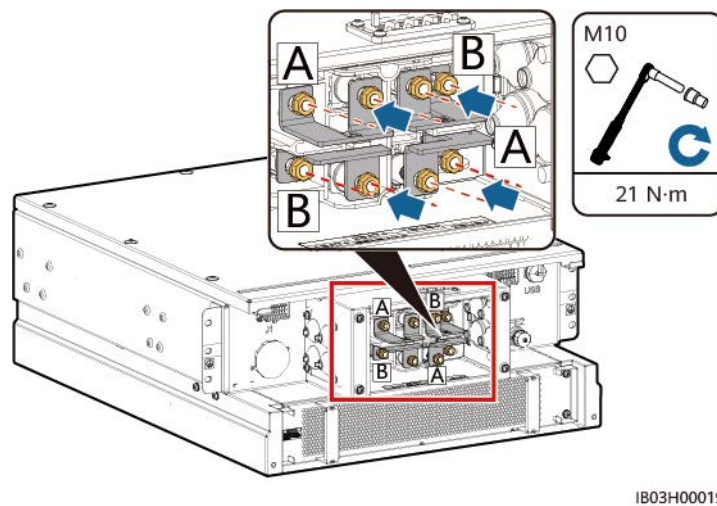
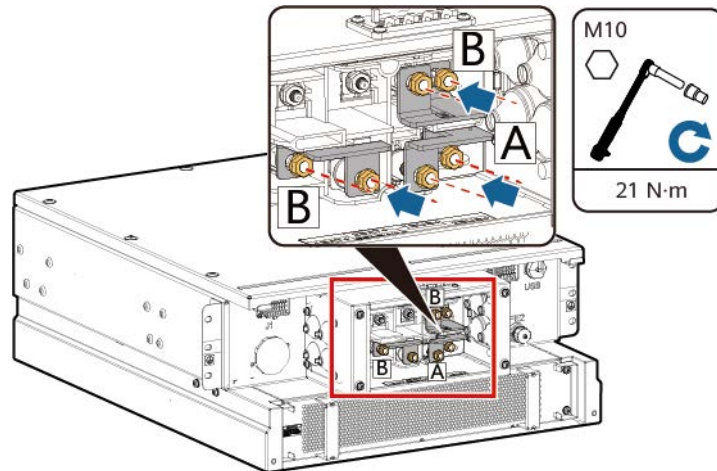

Figure 7-37 Installing short-circuiting copper bars (97 kWh/129 kWh/161 kWh model)



5000003

Step 3 Install the maintenance compartment cover and the decorative cover to the rack controller.

Figure 7-38 Installing covers

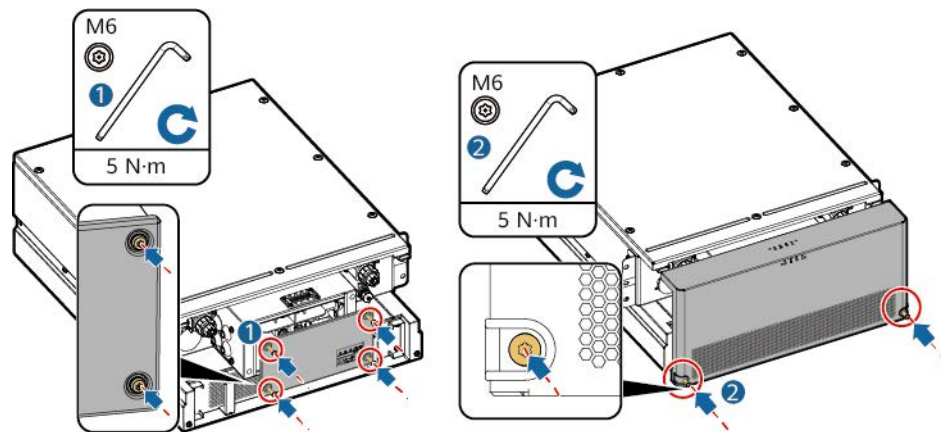

Step 4 Remove cables bound on the outside of the ESS.

Figure 7-39 Removing bound cables

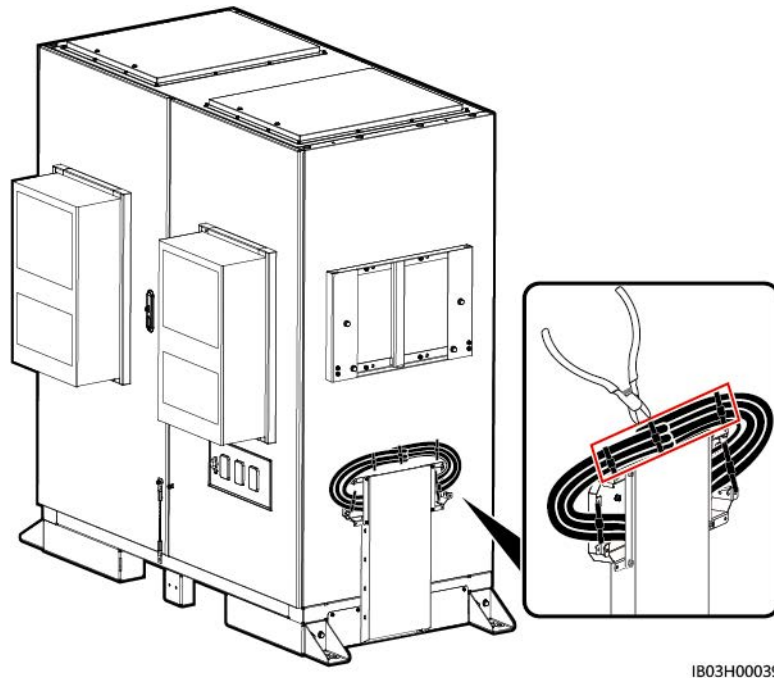

Step 5 Install the upper bracket, lower bracket, rainproof canopy, and lifting handles to the rack controller.

NOTE

- The upper bracket, lower bracket, rainproof canopy, and lifting handles are delivered with the product.
- The screws for securing the upper and lower brackets are preinstalled on the rack controller. Remove the screws before installing the upper and lower brackets.
- The screws for securing the rainproof canopy are preinstalled on the upper bracket. Remove the screws before installing the rainproof canopy.
- When using the lifting handles, hold the handle end closer to the device.

Figure 7-40 Installing mounting kits

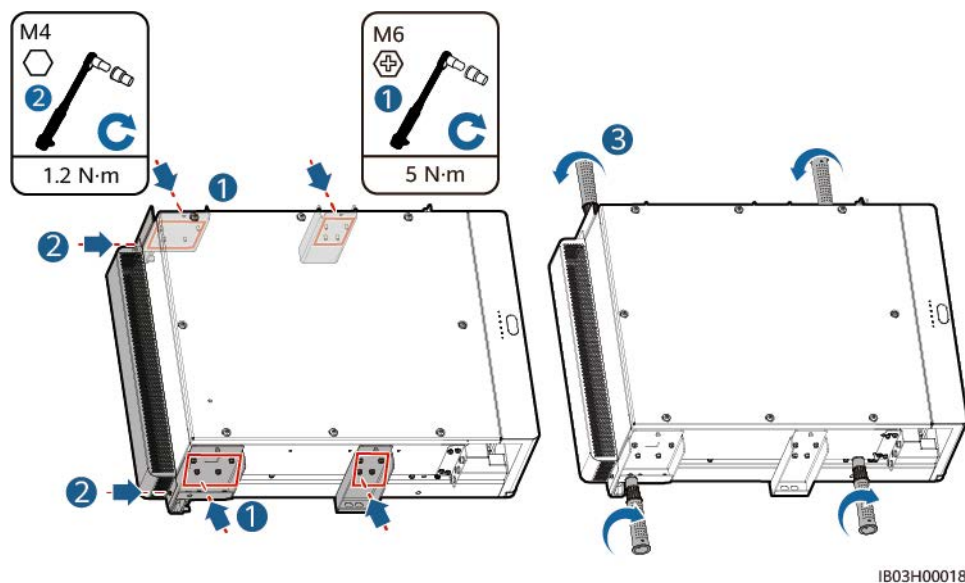

Step 6 Install the rack controller to the mounting bracket on the ESS.

NOTE

- The M8 screws are used to secure the rack controller. Keep them properly after removing them.
- At least three persons are required to install the rack controller.

Figure 7-41 Installing the rack controller

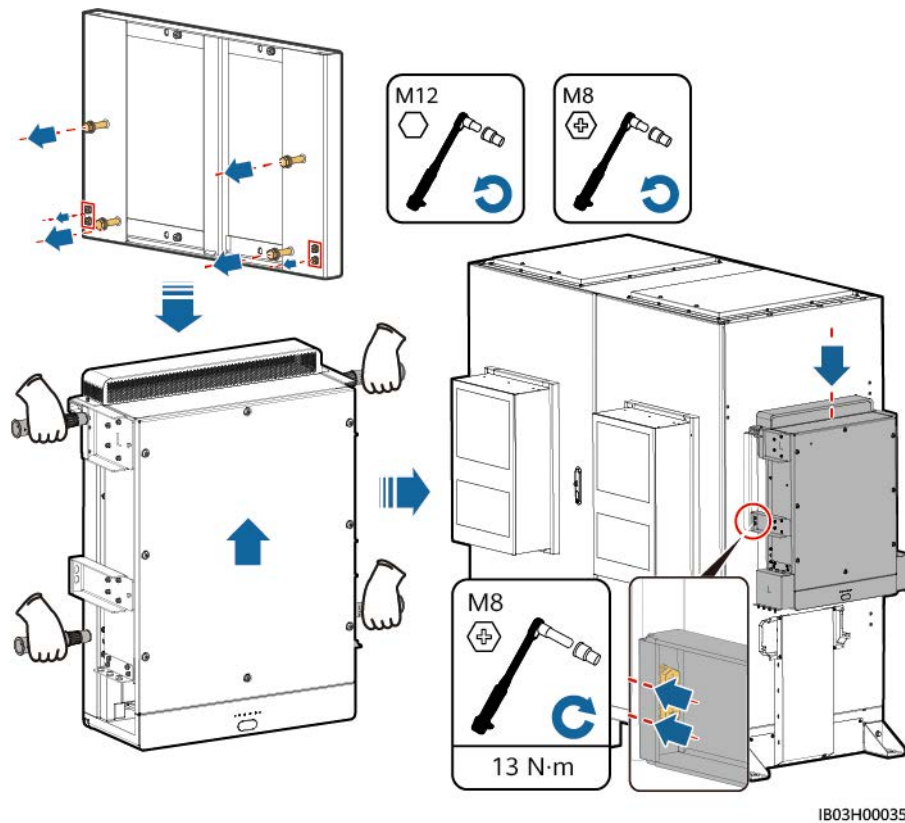

----End

7.4.4 Installing the Smart PCS

Prerequisites

Unpack and check the Smart PCS delivered to the site to ensure that the Smart PCS is complete and intact.

Procedure

Step 1 Install the mounting bracket. The mounting bracket is delivered with the Smart PCS.

Figure 7-42 Installing a mounting bracket

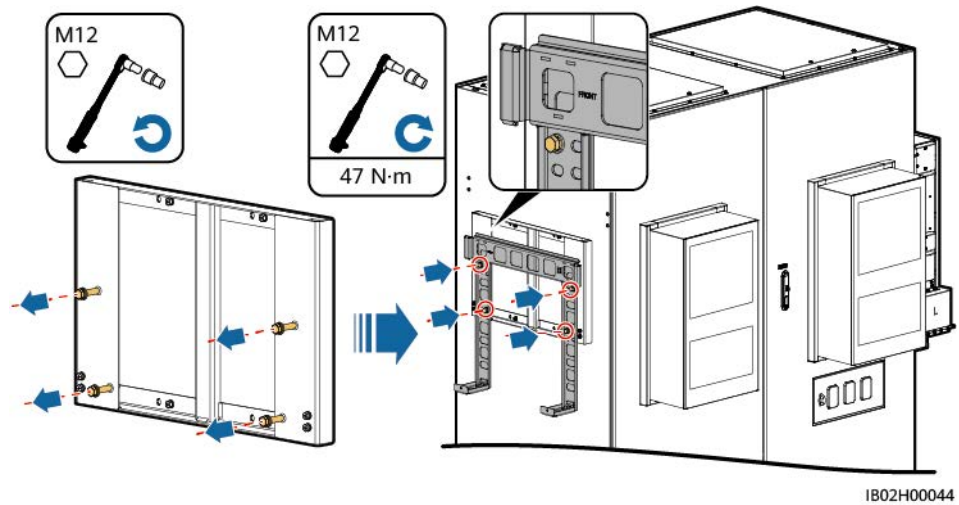

Step 2 Install mounting ears and lifting handles. The mounting ears are delivered with the Smart PCS, and the lifting handles are delivered with the ESS.

NOTE

- At least four persons are required to install the Smart PCS.
- When using the lifting handles, hold the handle end closer to the device.

Figure 7-43 Installing mounting ears and lifting handles

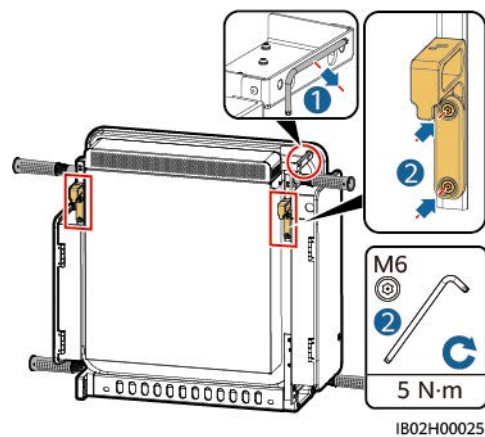

Step 3 Secure the Smart PCS.

Figure 7-44 Securing the Smart PCS

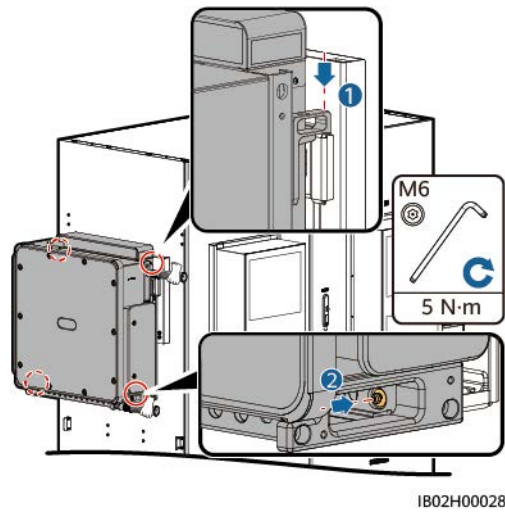

----End

7.4.5 (Optional) Installing a Maintenance Socket

Context

The 220 V socket is prepared by the customer. The actual socket appearance may vary. This section describes only the installation method.

Procedure

- Step 1** Remove the baffle plate in front of the power distribution area.
- Step 2** Install the maintenance socket.

Figure 7-45 Installing the socket

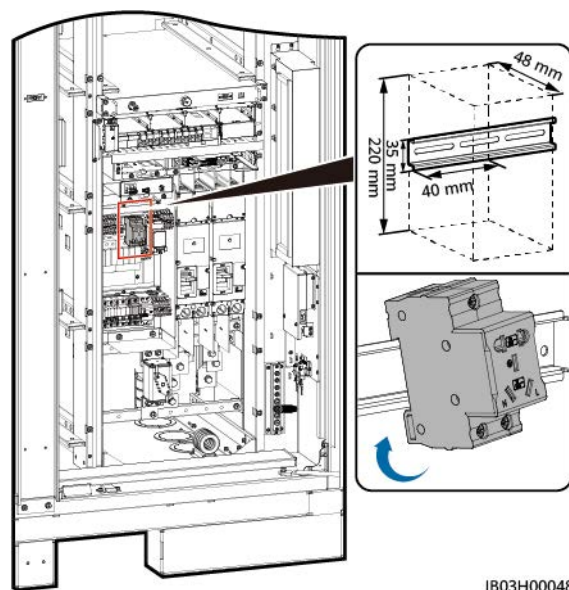

----End

7.4.6 (Optional) Installing a DDSU666-H

Context

The DDSU666-H meter is purchased from the Company.

Procedure

Step 1 Remove the baffle plate in front of the power distribution area.

Step 2 Install the DDSU666-H.

Figure 7-46 Installing the DDSU666-H

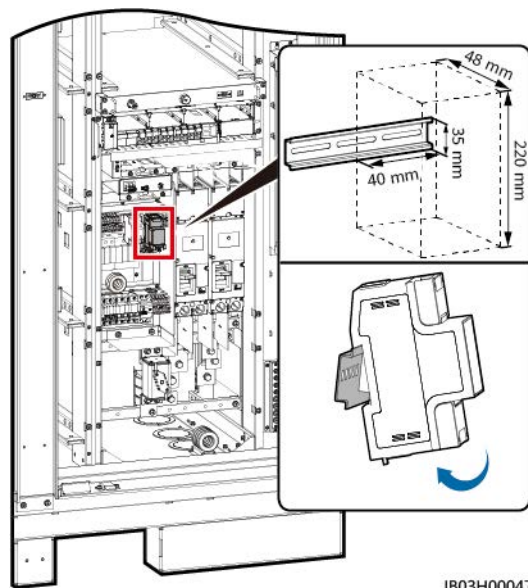

IB03H00047

----End

8 Installing Cables

 **DANGER**

Note the polarities when installing batteries. Do not connect the positive and negative poles of a battery or battery string together. Otherwise, the battery may be short-circuited.

 **DANGER**

- Do not smoke or have an open flame around batteries.
 - The site must be equipped with qualified fire fighting facilities, such as fire sand and carbon dioxide fire extinguishers.
 - Wear personal protective equipment and use dedicated insulated tools to avoid electric shocks or short circuits.
-

 **WARNING**

Tighten the screws on copper bars or cables to the torque specified in this document. Periodically confirm whether the screws are tightened, check for rust, corrosion, or other foreign objects, and clean them up if any. Loose screw connections will result in excessive voltage drops and batteries may catch fire when the current is high.

 **CAUTION**

- When connecting batteries, ensure that the spring washer on the screw is leveled, that the protruding part of the terminal on the cable faces outwards, and that the cable is intact.
- Do not connect two or more cables to the positive or negative power port of a battery in parallel.
- Stay away from the equipment when preparing cables to prevent cable scraps from entering the equipment. Cable scraps may cause sparks and result in personal injury and equipment damage.

 **NOTE**

The cable colors shown in the electrical connection diagrams provided in this section are for reference only. Select cables in accordance with local cable specifications. (Green-and-yellow cables are only used for protective earthing.)

8.1 Preparing Cables

 **NOTE**

The cable diameter must comply with local cable standards. The factors that affect cable selection include the rated current, cable type, routing mode, ambient temperature, and maximum expected line loss.

Name	Type	Conductor Cross-Sectional Area	Outer Diameter	Terminal	Source
Ground cable for the rack controller	Single-core outdoor copper cable	$\geq 25 \text{ mm}^2$	-	M6 OT/DT terminal	Prepared by the customer
DC power cable	Prefabricated DC power cable (with a corrugated pipe)	-	-	-	Delivered with the product
Auxiliary AC power cable (with external grid power supply)	Two-core (L, N)/ Three-core (L, N, PE) outdoor copper/copper-clad aluminum/aluminum alloy cable	6–25 mm ²	12.7–27 mm	Cord end terminal with an insertion depth of 12 mm, M8 OT/DT terminal	Prepared by the customer

Name		Type	Conductor Cross-Sectional Area	Outer Diameter	Terminal	Source
Single-phase AC input power cable (without external grid power supply)		Two-core/Three-core outdoor copper/copper-clad aluminum/aluminum alloy cable	6–25 mm ²	12.7–27 mm	Cord end terminal with an insertion depth of 12 mm, M8 OT/DT terminal	Prepared by the customer
Network cable		CAT 5E outdoor shielded network cable, internal resistance ≤ 1.5 ohms/10 m	-	≤ 9 mm	Shielded RJ45 connector	Prepared by the customer
Optical fiber cable		Four-core or eight-core single-mode armored cable with the transmission wavelength of 1310 nm	-	≤ 18 mm	-	Prepared by the customer
(Optional) Cable to the DDSU666-H	RS485 communications cable	-	-	-	-	Preinstalled before delivery
	Current transformer cable and power cable	-	-	-	-	Delivered with the product
(Optional) Cable to the maintenance socket	Power cable and ground cable	-	-	-	-	Delivered with the product

8.2 Installing Cables for the Rack Mounted Fire Extinguishing System

Step 1 Take out the reserved cables and install them to the rack mounted fire extinguishing system.

WARNING

Ensure that the cables are correctly installed. If a fire occurs when cables are not connected or incorrectly connected, the ESS cannot actively extinguish the fire.

Figure 8-1 Connecting cables

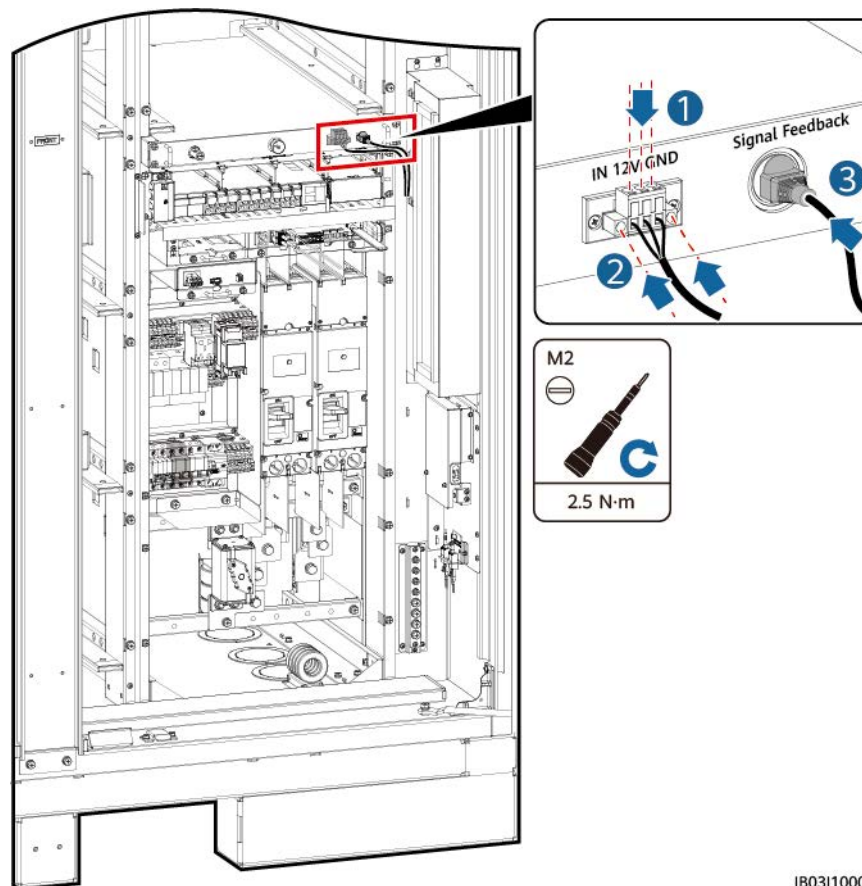

IB03110006

----End

8.3 Installing Battery Pack Cables

Step 1 Install copper bars for battery packs, and connect the battery rack general output power cable and black start cable.

 **NOTE**

- One ends of the battery rack general output power cable and black start cable are preinstalled before delivery.
- No copper bar is required for the preinstalled dummy battery packs of 97 kWh, 129 kWh, and 161 kWh models.
- There are four types of copper bars delivered with the product: A, B, C, and D.
- Keep the redundant copper bars of the 97 kWh, 129 kWh, and 161 kWh models properly for later use.
- Copper bar D must be installed before copper bar B.
- There are two types of M10 nuts for securing copper bars. Select a 15 mm or 16 mm socket based on the site requirements.
- When installing a nut, manually insert the nut into the screw plate, and then use a socket wrench to completely secure the nut in place. This prevents the screw thread from being stuck or stripped due to the deviation of the nut position.
- Preinstall nuts according to the recommended torque of 27 N·m.
- Verify the torque of the installed nuts using a torque socket wrench set to 27 N·m.
- Mark the nuts whose torque has been verified using a marker.

Figure 8-2 Installing copper bars and cables (200 kWh model)

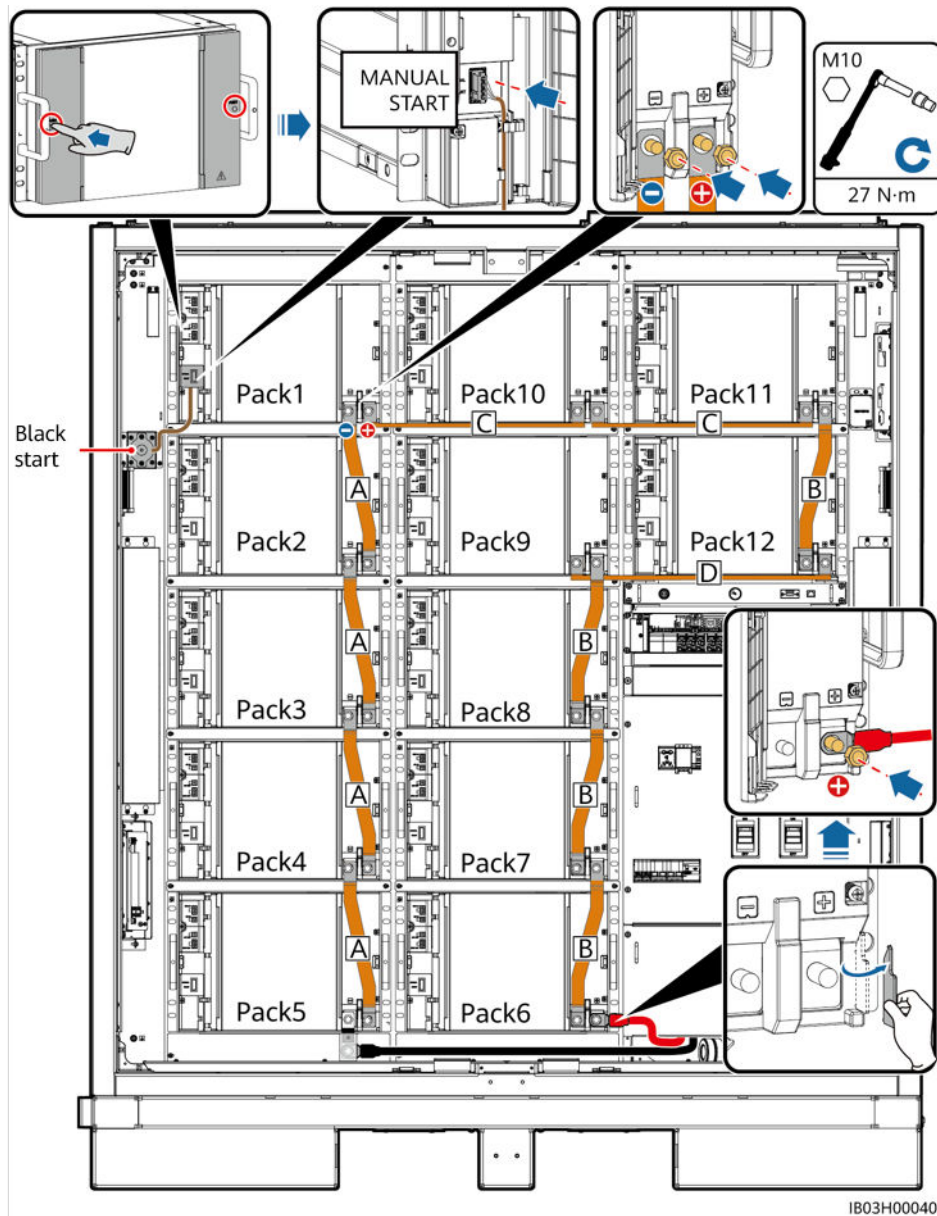

Figure 8-3 Installing copper bars and cables (161 kWh model)

NOTE

Connect the black start cable to Pack1.

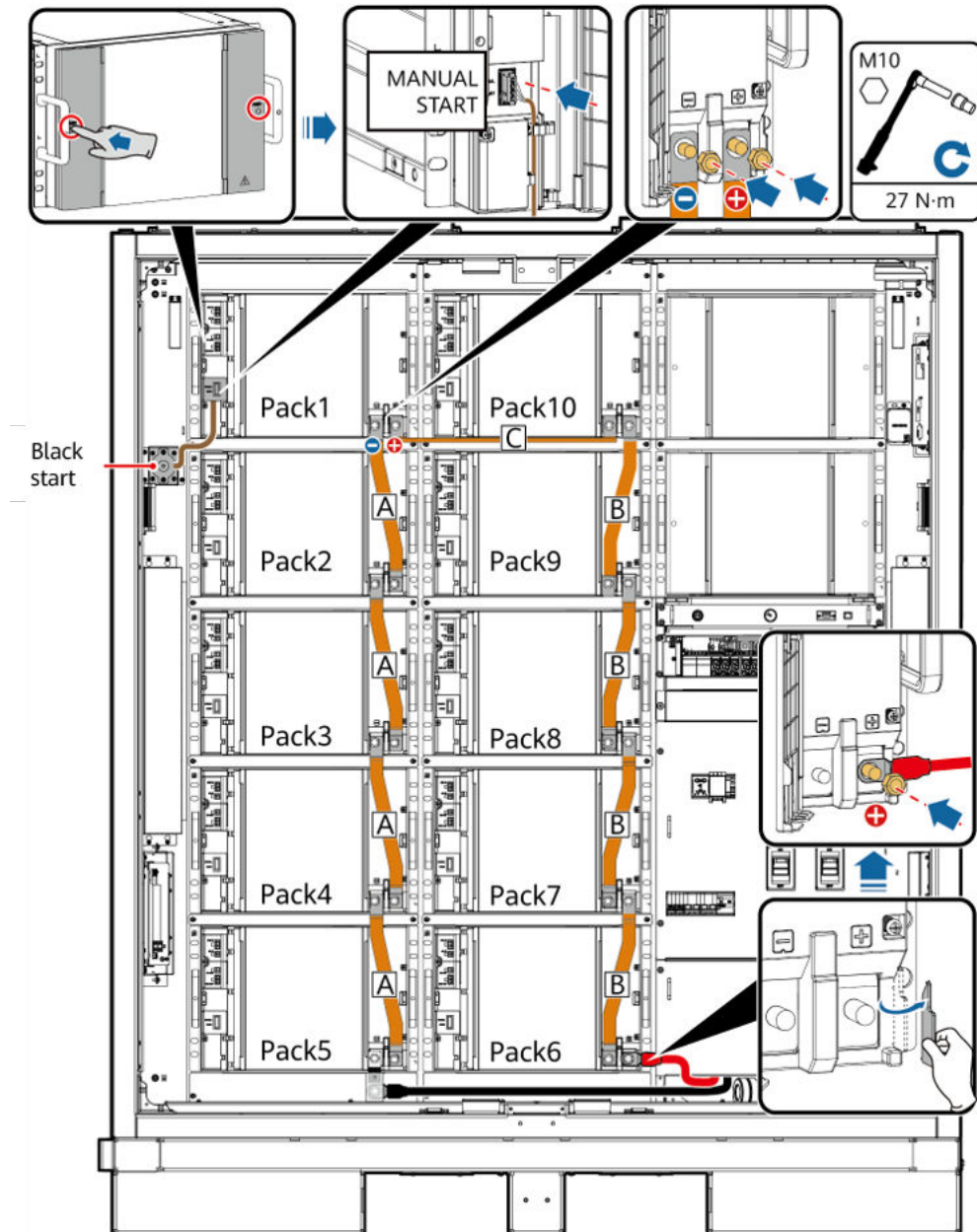

Figure 8-4 Installing copper bars and cables (129 kWh model)

NOTE

Connect the black start cable to Pack2.

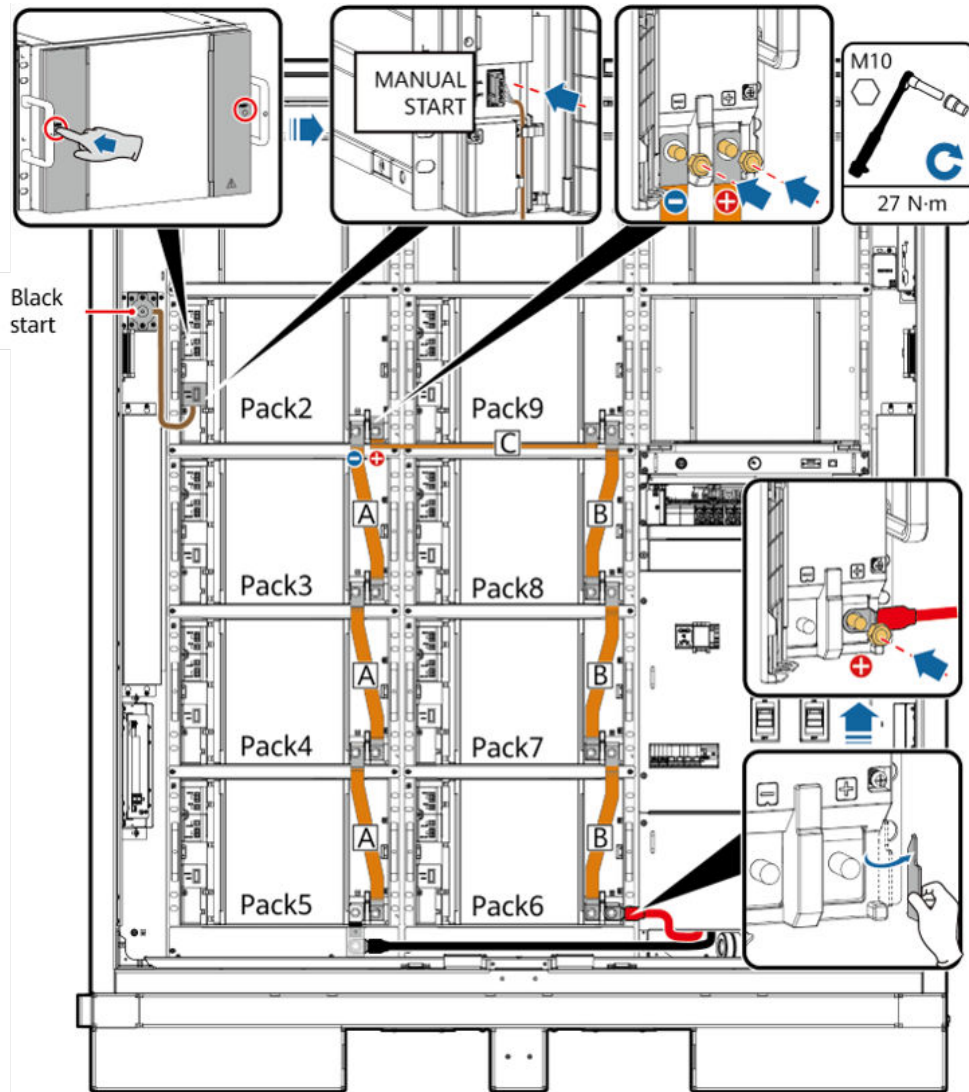
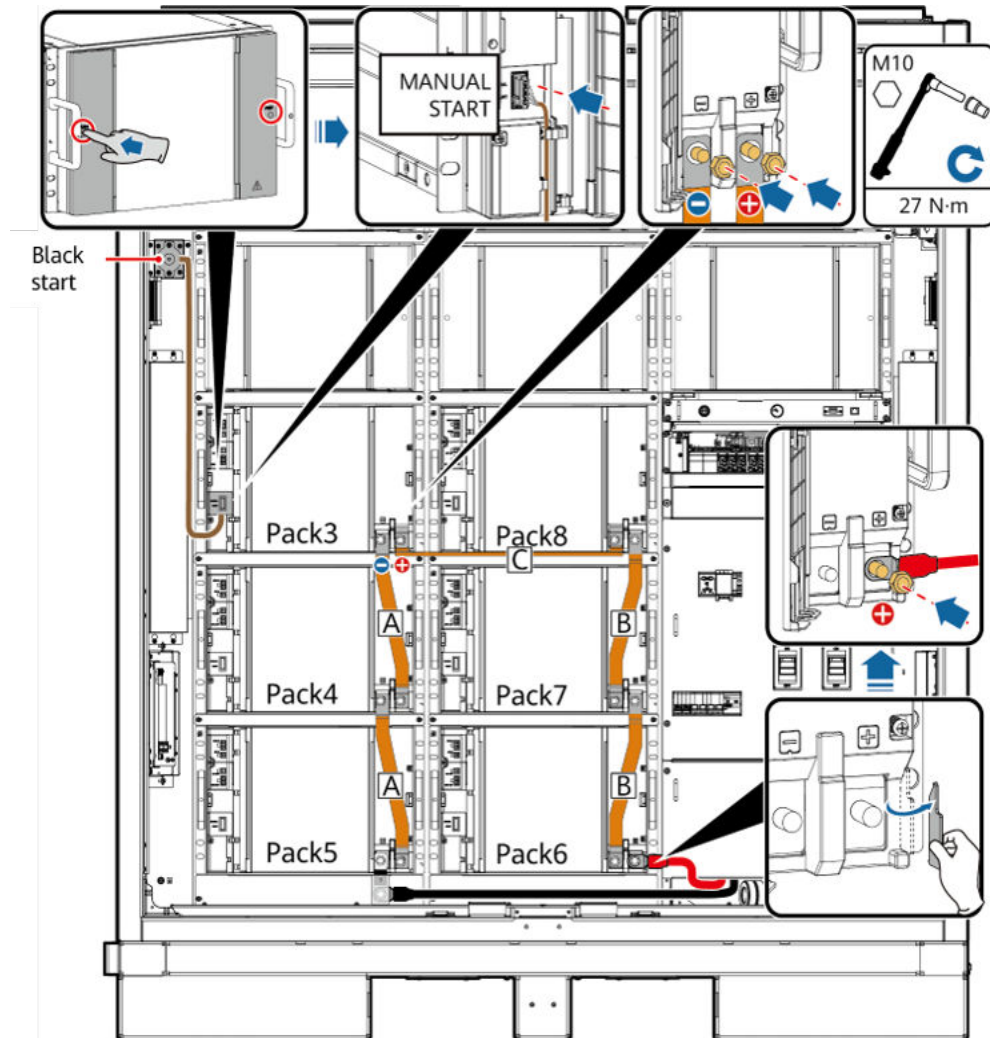

Figure 8-5 Installing copper bars and cables (97 kWh model)

NOTE

Connect the black start cable to Pack3.



Step 2 Connect 48 V cables to the battery packs.

NOTE

- The 48 V cables of all models are connected in the same way.
- Cables to 2FCB6 and 2FCB7 are preinstalled before delivery.
- Other 48 V cables are delivered with the product.
- The cable between Pack10 and Pack11 is 04097837-10 or 04098675-10, and the other cables are 04097837-07 or 04098675-07.
- The cable sequence is as follows: 2FCB6-Pack1-2-3-4-5, 2FCB7-Pack12-11-10-9-8-7-6.
- Keep redundant cables properly for later use.

Figure 8-6 Connecting 48 V cables to battery packs

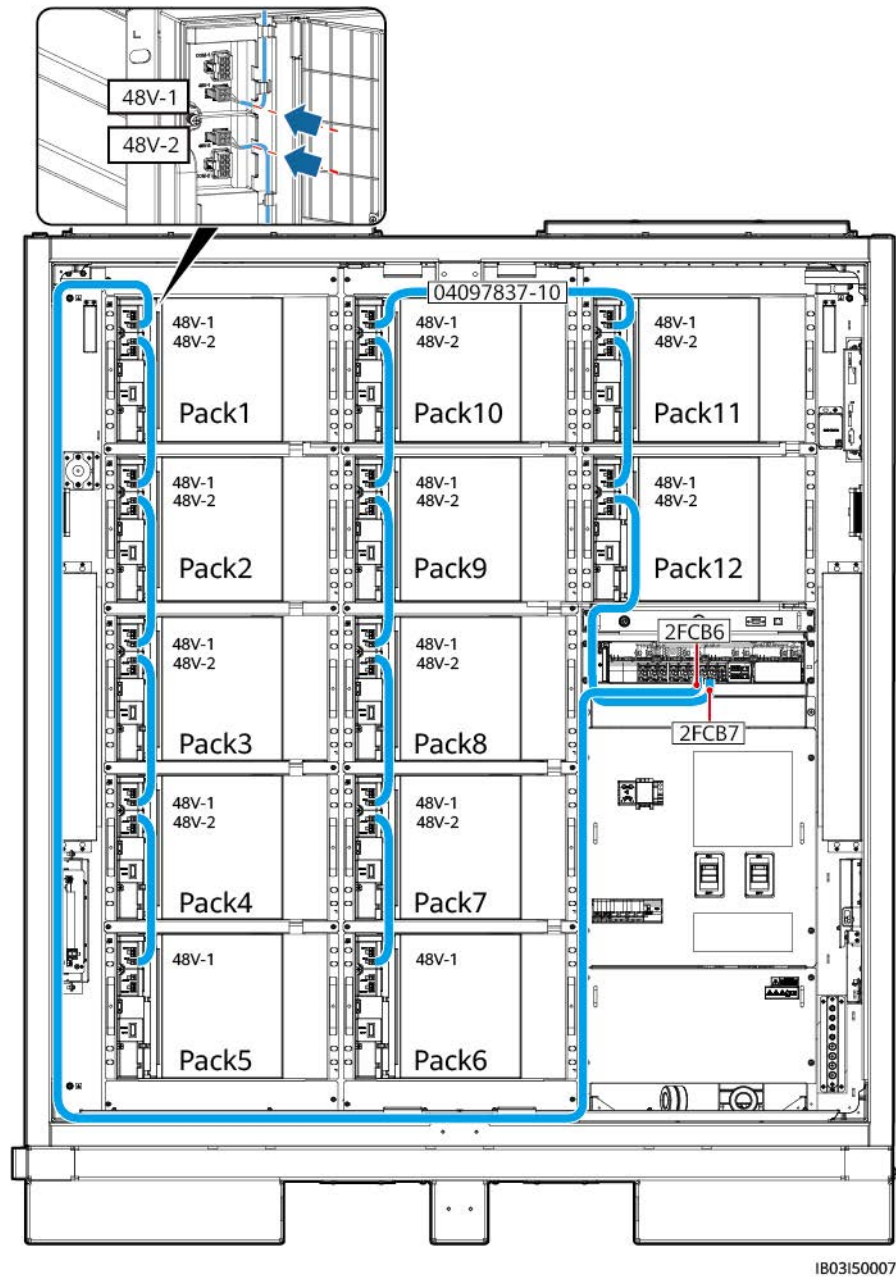

1803150007

Step 3 Connect cables to the COM ports on the battery packs.

 NOTE

- The COM cables of all models are connected in the same way.
- Cables to COM-1 on Pack1 and COM-2 on Pack12 are reserved before delivery. After connecting the cables to the battery packs, bind the cables inside the cabinet. Connect the other ends of the cables after installing the rack controller.
- Other COM port cables are delivered with the product.
- The cable sequence is as follows: Pack1-2-3-4-5-6-7-8-9-10-11-12.
- The cable between Pack5 and Pack6 is 04097837-08 or 04098675-08, the cable between Pack10 and Pack11 is 04097837-09 or 04098675-09, and the other cables are 04097837-06 or 04098675-06.
- Keep redundant cables properly for later use.

Figure 8-7 Connecting cables to the COM ports on the battery packs

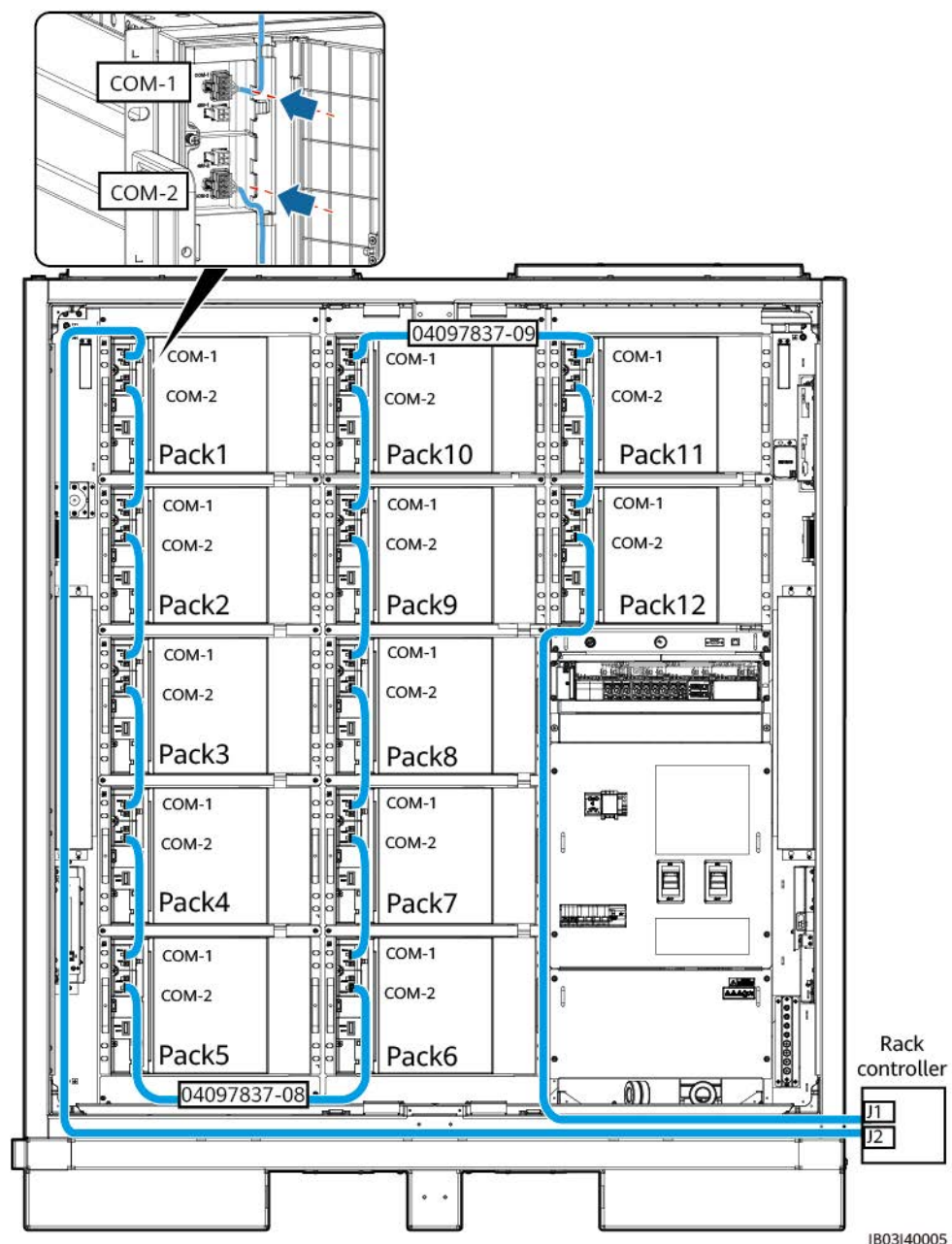

Step 4 Close the terminal covers of the battery packs.

----End

8.4 Installing Rack Controller Cables

Step 1 Remove the decorative cover and maintenance compartment cover from the rack controller.

Figure 8-8 Removing covers

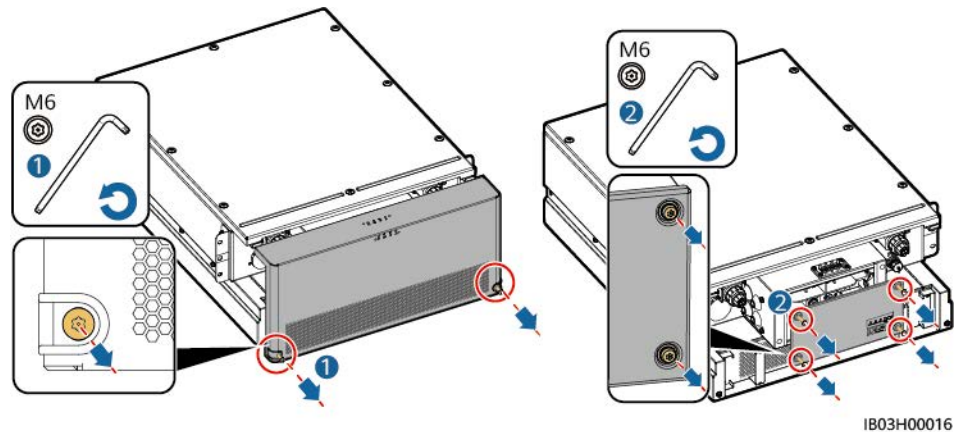

Step 2 Check whether the short-circuiting copper bars are installed. For details, see [7.4.3 Installing the Smart Rack Controller](#).

Step 3 Connect the preinstalled cables to the BAT/BUS ports. Magnetic rings are delivered with the product.

NOTICE

- The black magnetic ring is installed on the left side of the rack controller, and the green magnetic ring is installed on the right side of the rack controller.
- Do not remove the cover from an unused pagoda connector.

Figure 8-9 Connecting cables (200 kWh model)

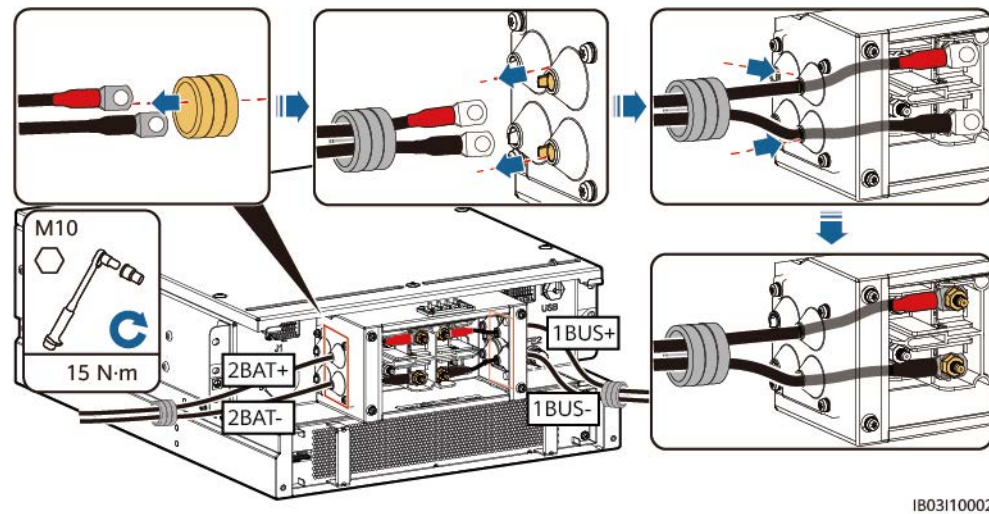

IB03110002

Cable Label	Wiring Terminal
107-1F1:2>TA1:2BAT+	2BAT+
108-1Q2:1>TA1:1BUS+	1BUS+
109-1Q1:4>TA1:2BAT-	2BAT-
111-1Q2:3>TA1:1BUS-	1BUS-

Figure 8-10 Connecting cables (97 kWh/129 kWh/161 kWh model)

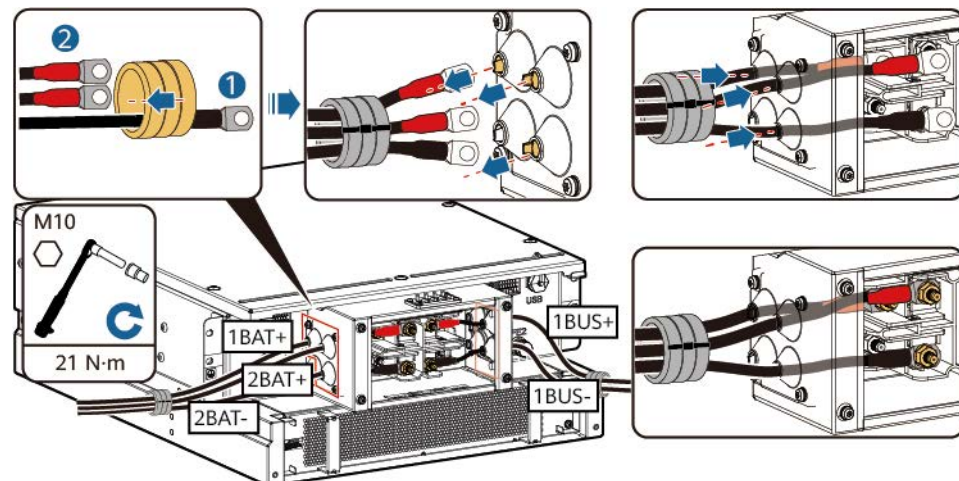

Cable Label	Wiring Terminal
110-1F2:2>TA1:1BAT+	1BAT+
107-1F1:2>TA1:2BAT+	2BAT+
108-1Q2:1>TA1:1BUS+	1BUS+

Cable Label	Wiring Terminal
109-1Q1:4>TA1:2BAT-	2BAT-
111-1Q2:3>TA1:1BUS-	1BUS-

Step 4 Connect the preinstalled cables to J1 (left), J2 (right), and FE1.

Figure 8-11 Connecting cables

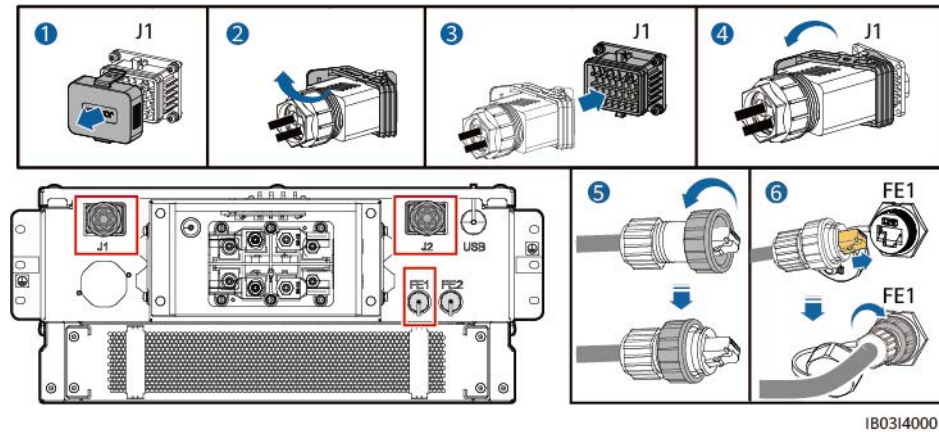

Table 8-1 Communications port description

Com munications Port	Port Description	Cable Connection
FE1	For communication between the rack controller and nearby components	Connect the rack controller to the LAN port on the CMU in the ESS.
FE2	For ring network communication with multiple rack controllers	The FE2 port does not need to be connected. Each ESS is configured with only one rack controller. In this case, the rack controller does not need to be cascaded.

NOTE

- When securing the network cable (as shown by ⑥ in the figure), hold the cable and align it with the FE network port. After the network cable is properly installed, do not release it. Use the other hand to tighten the nut of the RJ45 connector.
- After the network cable is installed, gently pull it down to check that it is properly installed.

Step 5 Install the maintenance compartment cover and decorative cover to the rack controller, and place the magnetic rings.

Figure 8-12 Installing covers

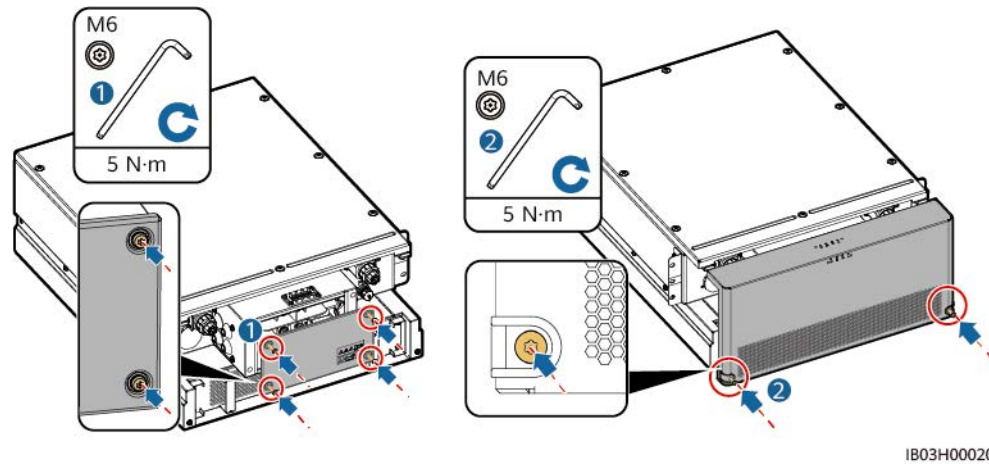

Step 6 Install the protective covers delivered with the product, connect a ground cable to the protective cover on the left or right side, and bind the cable.

Figure 8-13 Connecting a ground cable

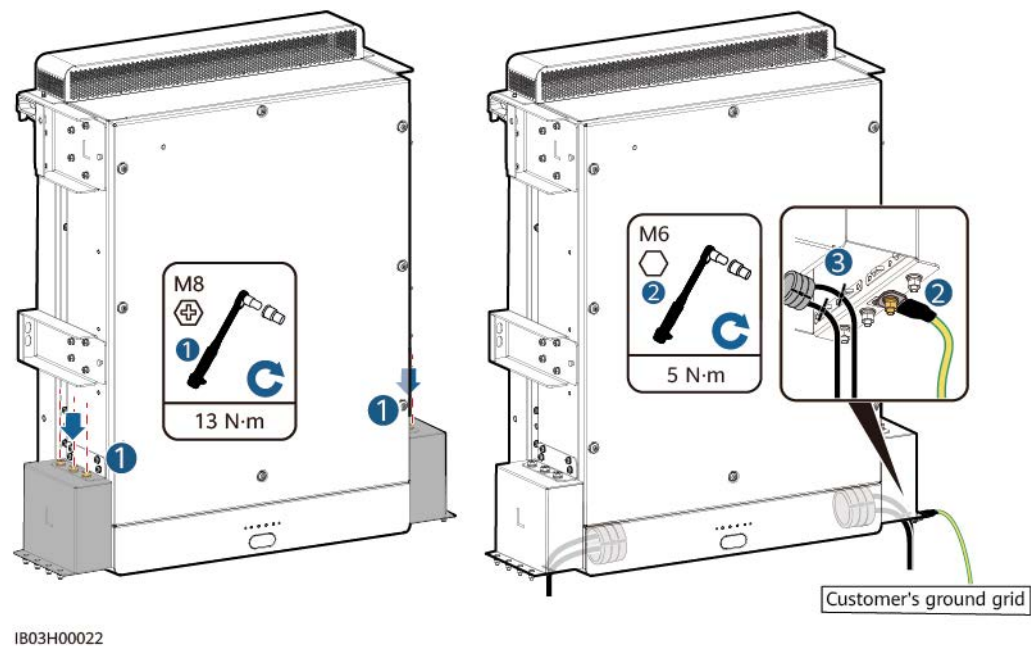

----End

8.5 Installing a DC Power Cable

Prerequisites

The DC power cable has been pre-buried.

Procedure

Step 1 Remove the baffle plate in front of the power distribution area.

- Step 2** Route the DC power cable through the cable hole at the bottom and connect it to the DC circuit breaker.

Figure 8-14 Connecting the DC power cable

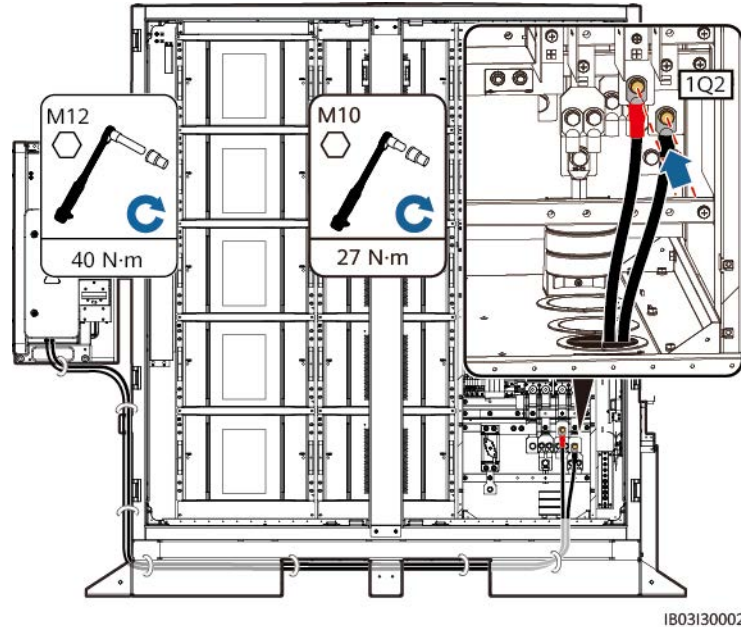

NOTE

- Reserve sufficient length of the cable and add angle steel in the middle of the foundation to support the cable and reduce the stress on the cable.
- The prefabricated DC power cables are delivered with the product. The terminals at two ends of a DC power cable are applicable to M10 and M12 screws respectively. Connect the M10 terminal to the DC circuit breaker 1Q2 in the cabinet, and connect the M12 terminal to the DC side of the Smart PCS.
- For details about how to install other cables for the Smart PCS, see the corresponding quick guide.

----End

8.6 Installing AC Power Cables for Auxiliary Power Supply

Prerequisites

The AC power cable has been pre-buried.

NOTICE

Obtain the AC auxiliary power from the mains or a reliable power supply. Do not directly obtain power from the AC side of renewable energy inverters such as PV inverters and wind power converters.

Procedure

- Step 1** Connect the AC power cable to the auxiliary power supply. Route the AC power cable through the cable hole at the bottom and connect it to the MCB.

Figure 8-15 Connecting the AC power cable to the auxiliary power supply

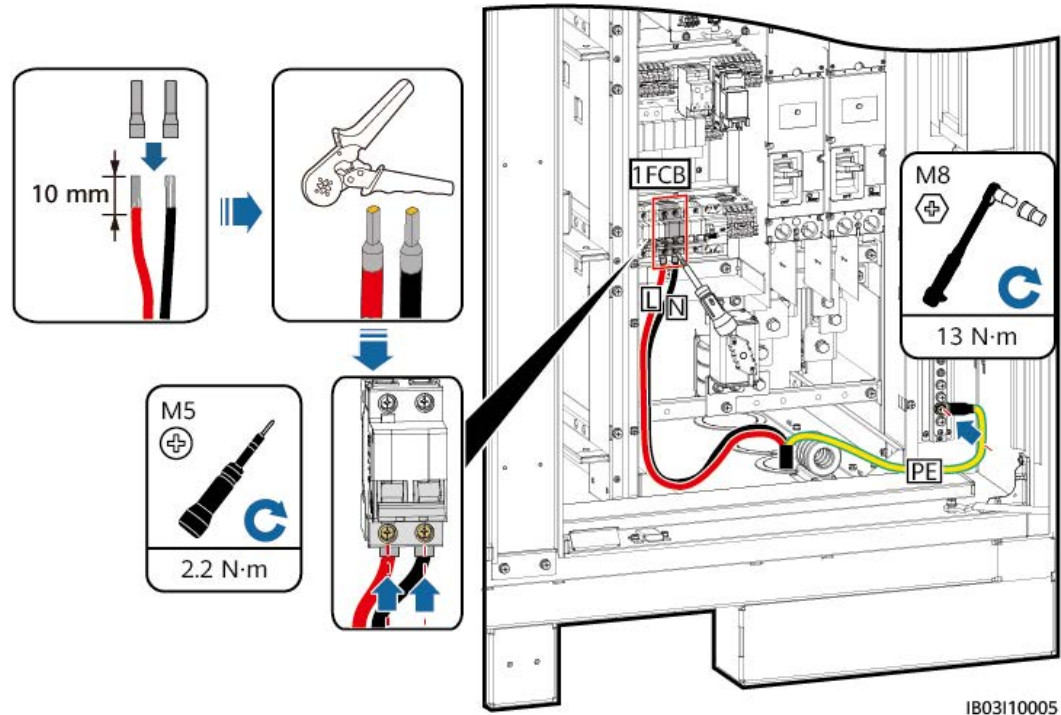

----End

8.7 Installing AC Input Power Cables for the UPS

In off-grid scenarios, a UPS must be configured. To connect the AC input power cable to the UPS, perform the following steps: (Recommended UPS input switch specifications: 230/400 V AC 32 A/2P)

NOTICE

Obtain the AC auxiliary power from the mains or a reliable power supply. Do not directly obtain power from the AC side of renewable energy inverters such as PV inverters and wind power converters.

- Step 1** Remove the short-circuiting bar from 1-2 and insert it to 2-3 on the XU terminal block.
- Step 2** Remove the short-circuiting bar from 4-5 and insert it to 5-6 on the XU terminal block.
- Step 3** Connect the cable.

Figure 8-16 Connecting the cable

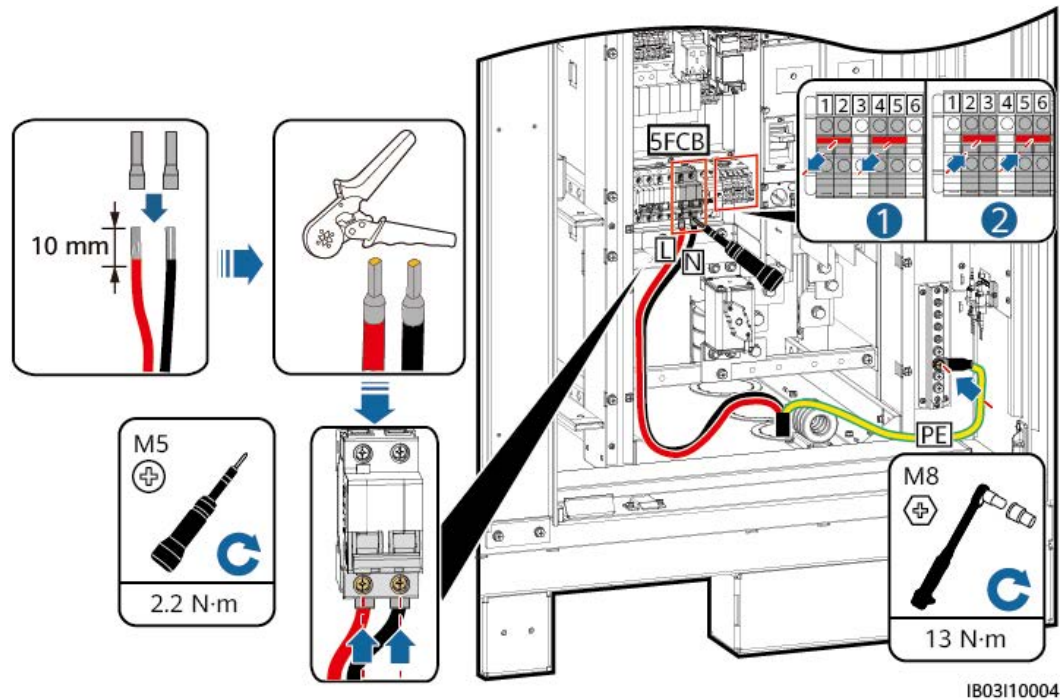

----End

8.8 Installing Communications Cables

8.8.1 Installing an FE Communications Cable

Step 1 Connect the FE communications cable to the **WAN** port on the CMU.

NOTE

Route the FE communications cable through the magnetic rings at the cable hole to improve signal quality.

Figure 8-17 Connecting the FE communications cable

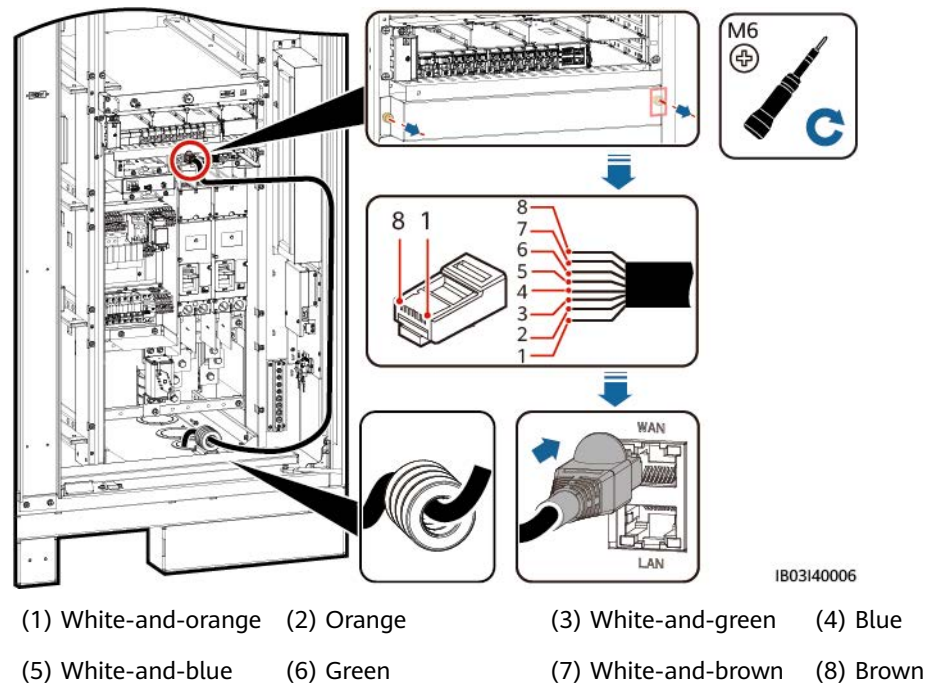

Step 2 Bind the cable.

----End

8.8.2 Installing Fiber Ring Network Communications Cables

NOTICE

Only professionals are allowed to connect optical fiber cables and splice fibers.

NOTE

In the optical fiber ring topology, two optical fiber cables are required.

Figure 8-18 Access terminal box (ATB) interior

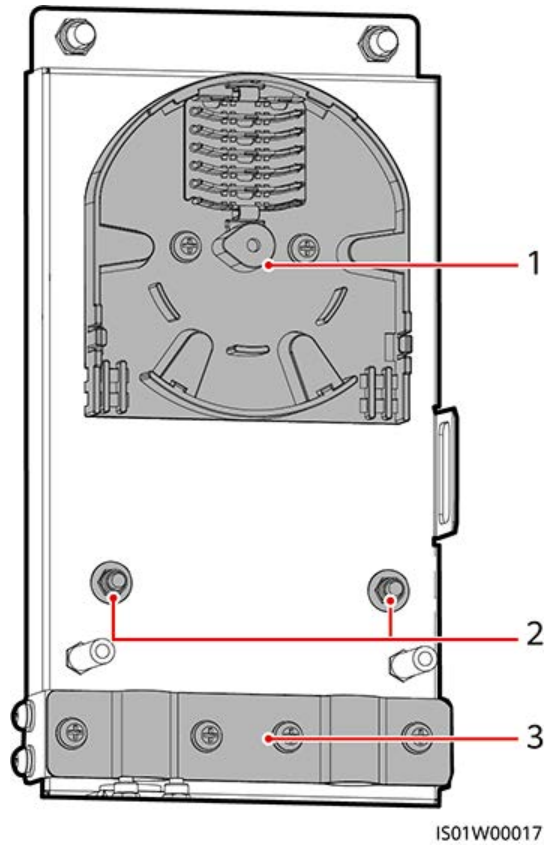

(1) Fiber spool

(2) Fixing points for internal
steel wires of optical fiber
cables

(3) Cable clip

Step 1 Remove the external mechanical parts from the ATB.

Figure 8-19 Removing external mechanical parts

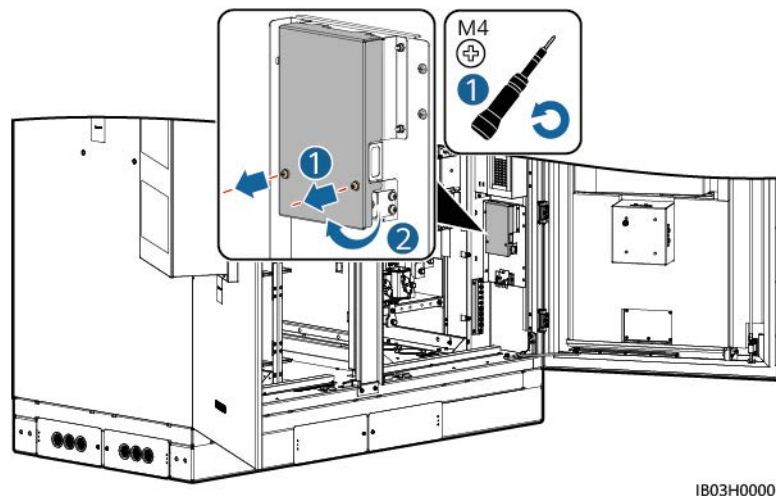

Step 2 Remove the optical fiber cable fastener.

Figure 8-20 Removing the fastener

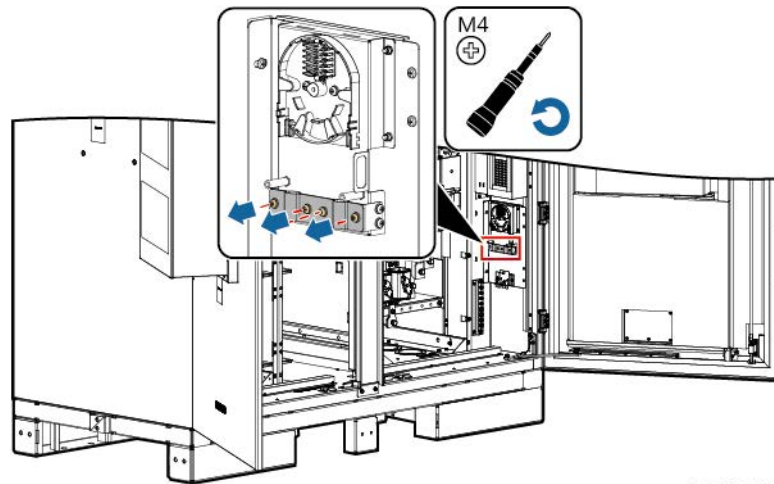

Step 3 Connect one end of the optical jumper to the fiber adapter.

Step 4 Route the other end of the optical jumper through the cable hole on the side of the ATB, and connect the cable to the ATB.

Step 5 Connect the peripheral optical fiber cable to the ATB, splice the optical fiber cable and the optical jumper, and then wind the spliced cable around the fiber spool on the ATB.

Figure 8-21 Connecting optical fiber cables

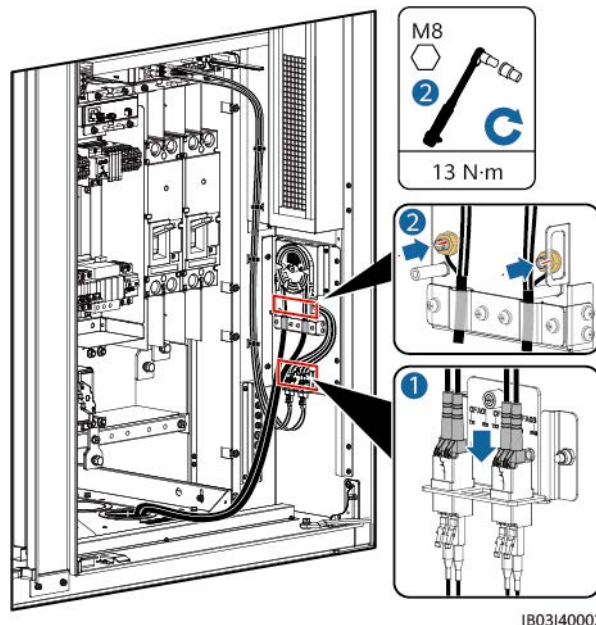

Step 6 Check that the cables are connected correctly and securely. Then reinstall the optical fiber cable fastener and external mechanical parts.

----End

8.9 (Optional) Installing DDSU666-H Cables

Table 8-2 Cable connection

Name	DDSU666-H Side	ESS Side
RS485 communications cable	485A	K1-COM1:+>1PGH1:485A (preinstalled before delivery)
	485B	K1-COM1:->1PGH1:485B (preinstalled before delivery)
Current transformer cable	CT:5 I* (white) CT:6 I (blue)	XT1:1:2>1FCB:1
Power cable	L	XT1:3:1>1PGH1:L
	N	XT2:3:1>1PGH1:N

Figure 8-22 Connecting cables

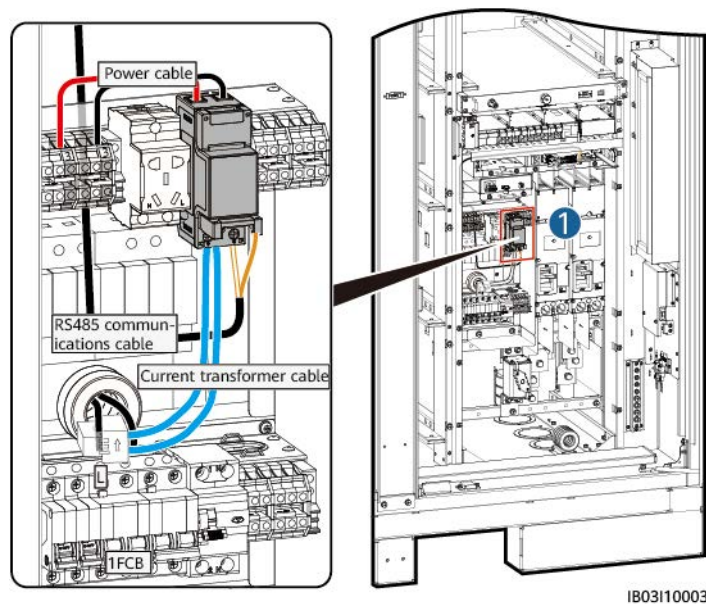

NOTE

If the ESS is connected to an external UPS, the connection method is the same. However, in this scenario, the DDSU666-H cannot measure the power consumption of the 12 V adapter and there is a maximum error of 0.024 kWh per hour.

8.10 (Optional) Installing Maintenance Socket Cables

NOTE

The actual appearance of the maintenance socket may vary. The figure shows only the installation method.

Figure 8-23 Connecting cables

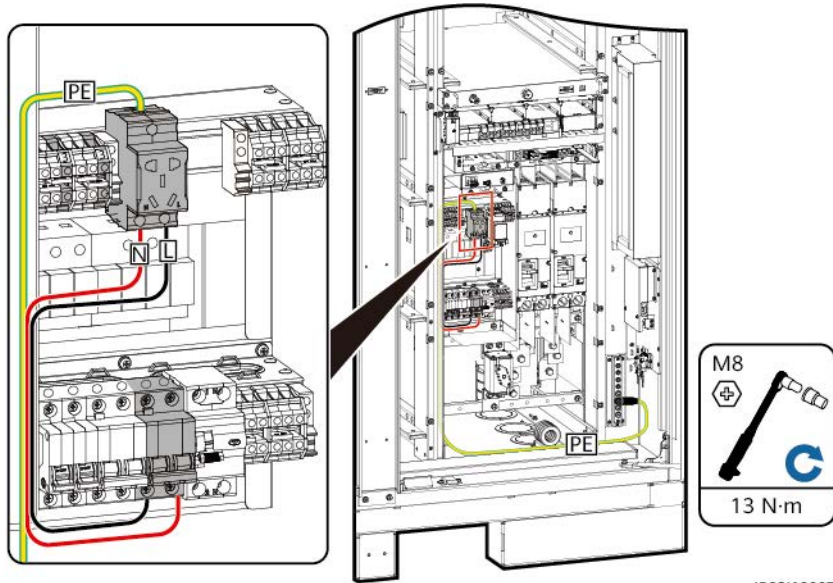

IB03110007

8.11 Sealing Cable Holes

After cables are installed, seal the cable holes using the delivered sealing putty.

Figure 8-24 Sealing putty

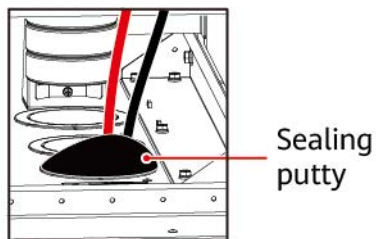

IB03W00018

9 Powering On the ESS

9.1 Check Before Power-On

9.1.1 General Check

No.	Check Item	Expected Result
1	Appearance	<ul style="list-style-type: none">• The equipment is intact and free from rust or paint flake-off. If the paint flakes off, repair the damaged paint.• The labels on the device are clear. Damaged labels must be replaced.
2	Cable appearance	<ul style="list-style-type: none">• Cable sheathings are properly wrapped and not damaged.• Cable hoses are intact.
3	Cable connection	<ul style="list-style-type: none">• Cables are connected in the designed positions.• Terminals are prepared as required and securely connected.• Labels on both ends of each cable are clear and specific, and attached in the same direction.
4	Cable routing	<ul style="list-style-type: none">• Electrical and extra low voltage (ELV) cables are routed separately.• Cables are neat and tidy.• Cable tie joints are evenly cut without burrs.• Cables are placed properly and with slack at bending points to avoid stress.• Cables are routed neatly without twists or crossovers in the cabinets.
5	Battery pack copper bar	The copper bar is not deformed, and the plastic dip coating is not damaged.

No.	Check Item	Expected Result
6	Switch	<ul style="list-style-type: none"> The DC LV Panel switch is set to OFF. The battery rack switch is set to OFF.

9.1.2 ESS Installation Check

Cabinet

No.	Check Item	Expected Result
1	Installation	<ul style="list-style-type: none"> The installation meets the design requirements. The cabinet is level, and each door opens normally.
2	Appearance	The cabinet surface is free from cracks, dents, and scratches. If the paint flakes off, repair the damaged paint.
3	Cabinet grounding	Each cabinet has at least two ground points and is grounded securely. The resistance of a bond shall be less than or equal to 0.1 ohms.
4	Accessory	The number and positions of external accessories installed meet design requirements.
5	Label	All labels are correct, clear, and complete.

Interior

No.	Check Item	Expected Result
1	Circuit breaker	The circuit breakers are OFF.
2	Copper bar	The copper bars are not deformed, and there are no foreign objects on the copper bars.
3	Cable	The bolts for installing the cables are tightened and the cables are not loose.
4	Cable hole sealing	Cable holes are sealed.
5	Battery pack	All battery packs are intact.

No.	Check Item	Expected Result
6	Foreign object	Foreign objects such as tools and remaining materials are cleared.
7	Baffle plate for the power distribution area	The baffle plate in the power distribution area is free from cracks, dents, scratches, openings, and looseness.
8	SPD	The SPD indicator is green.
9	Subcomponent (CMU, adapter, and rack mounted fire extinguishing system)	All components are intact.
10	Cabinet grounding	The ground conductor is reliably connected to the ground terminal board or copper bar of the cabinet.

9.2 Installing a PSU

Prerequisites

The PSU is secured inside the ESS during transportation and installed onsite.

NOTICE

- If a PSU is damaged, contact the local office.
 - Do not put your hands into the PSU slot to avoid electric shock.
 - In an outdoor scenario, you are advised to power on the PSU within 24 hours after unpacking. If the PSU cannot be powered on in time, place it in a dry indoor environment without corrosive gas.
-

Procedure

- Step 1** Push the locking latch leftwards.
- Step 2** Pull out the handle.
- Step 3** Gently push the PSU into its slot along the guide rails.
- Step 4** Push the handle upwards.
- Step 5** Push the locking latch rightwards to lock the handle.

Figure 9-1 Installing the PSU

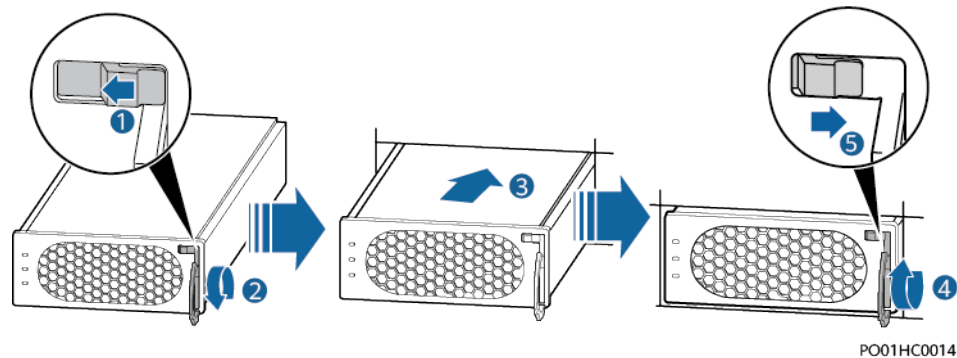

----End

9.3 Power-On Operations

⚠ DANGER

Wear insulated gloves and use insulated tools to prevent electric shocks or short circuits.

⚠ CAUTION

- During the power-on procedure, power off the batteries immediately if any fault is detected. Rectify the fault before proceeding with the procedure.
 - After batteries are used for system commissioning or batteries have discharged, charge the batteries in time. Otherwise, batteries may be damaged due to overdischarge.
 - Battery overdischarge and damage may occur if batteries with low SOC are stored. Batteries shall be recharged in a timely manner.
-

NOTICE

If the ESS has not been used for six months or longer after being installed, it must be checked and tested by professionals before operation.

Procedure

Figure 9-2 Positions of switches

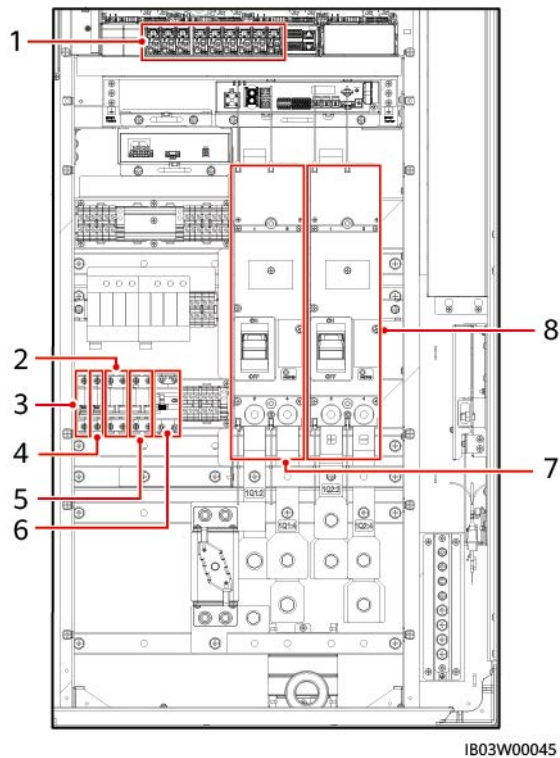

IB03W00045

- | | | |
|---|---|--|
| (1) 48 V DC power distribution switches | (2) AC main switch (1FCB) | (3) 12 V adapter switch (1FCB1) |
| (4) PSU switch (1FCB2) | (5) UPS switch (5FCB) | (6) 220 V maintenance socket switch (1FB1) |
| (7) DC switch (1Q1, on the battery rack side) | (8) DC switch (1Q2, on the Smart PCS DC side) | - |

- Step 1** Turn on the switch between the AC side of the ESS and the power grid.
- Step 2** Turn on the DC switch 1Q1. (As shown by 7 in [Figure 9-2](#))
- Step 3** Use a multimeter to check whether the AC voltage is within the allowed range (220 V±10%). (As shown by 2 in [Figure 9-2](#))
- Step 4** (Optional) Turn on the UPS cable inlet switch 5FCB (as shown by 5 in [Figure 9-2](#)).
- Step 5** Turn on the AC main switch 1FCB. (As shown by 2 in [Figure 9-2](#))
- Step 6** Turn on all switches in the power distribution system of the ESS.
1. Turn on the 12 V adapter switch 1FCB1. (As shown by 3 in [Figure 9-2](#))
 2. Turn on the PSU switch 1FCB2. (As shown by 4 in [Figure 9-2](#))
 3. (Optional) Turn on the 220 V maintenance socket switch 1FB1. (As shown by 6 in [Figure 9-2](#))
 4. On the embedded power subrack (SK1), turn on the DC/DC switch 2FCB1, DC light power switch 2FCB2, TCUE power switch 2FCB3, fan 1 switch 2FCB6, fan

2 switch 2FCB7, air conditioner 1 switch 2FCB8, and air conditioner 2 switch 2FCB9 in sequence.

 **NOTE**

Use a multimeter to check that the output voltage at position 1 in the preceding figure is $53\text{ V}\pm 5\text{ V}$.

Step 7 Turn on the DC switch 1Q2. (As shown by 8 in [Figure 9-2](#))

Step 8 Close the cabinet doors.

----**End**

10 Commissioning the ESS (SmartLogger WebUI)

This section describes deployment and commissioning in the on-grid scenario.

For details about deployment and commissioning in the microgrid scenario, see [Commercial and Industrial Microgrid Energy Storage Solution Quick Guide \(With Third-Party Microgrid Central Controller\)](#) or [Commercial and Industrial Microgrid Energy Storage Solution Quick Guide \(With SmartLogger-based Microgrid Control\)](#) based on the actual situation.

Prerequisites

1. All devices onsite have been commissioned.
2. The system is powered on and alarms are cleared.
3. The commissioning equipment is available onsite.
4. Before the deployment, wait until the air conditioners adjust the temperature inside the cabinet and the temperatures of all batteries to the specified temperature range (5°C to 45°C).

NOTE

The screenshots in this section correspond to FusionSolar V800R021C10SPC010. The screenshots are for reference only.

10.1 Preparations and WebUI Login

Prerequisites

- The operating system of Windows 7 or later is supported.
- Browser: Chrome 52, Firefox 58, or Internet Explorer 9, or a later version is recommended.
- It is recommended that a maximum of two users log in to the WebUI at the same time.

Procedure

- Step 1** Connect the network cable between the network port of the PC and the WAN or LAN port of the SmartLogger. It is recommended that the PC be connected to the LAN port of the SmartLogger.
- Step 2** Set the IP address for the PC on the same network segment as the SmartLogger IP address.

Connected Port	Item	SmartLogger Default Value	Example PC Setting
LAN port	IP address	192.168.8.10	192.168.8.11
	Subnet mask	255.255.255.0	255.255.255.0
	Default gateway	192.168.8.1	192.168.8.1
WAN port	IP address	192.168.0.10	192.168.0.11
	Subnet mask	255.255.255.0	255.255.255.0
	Default gateway	192.168.0.1	192.168.0.1

NOTE

- When the IP address of the WAN port is in the network segment from 192.168.8.1 to 192.168.8.255, set the default gateway to 192.168.8.1 and the IP address of the LAN port to 192.168.3.10. If the connected port is a LAN port, you need to adjust the network configuration of the PC.
- It is recommended that the PC be connected to the LAN port of the SmartLogger or the GE port of the SmartModule. When the PC is connected to the GE port of the SmartModule, adjust the network configuration of the PC to the configuration mode when the PC is connected to the LAN port of the SmartLogger.

- Step 3** Set LAN parameters.

NOTICE

- If the SmartLogger is connected to a LAN and a proxy server has been configured, you need to cancel the proxy server configurations.
- If the SmartLogger is connected to the Internet and the PC is connected to the LAN, do not cancel the proxy server configurations.

-
1. Open Internet Explorer.
 2. Choose **Tools > Internet Options**.
 3. Click the **Connections** tab and then click **LAN settings**.
 4. Clear **Use a proxy server for your LAN**.

Figure 10-1 LAN settings

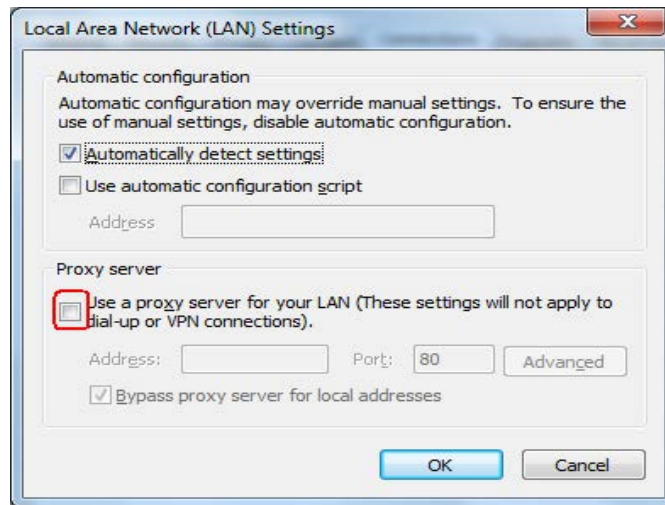

5. Click **OK**.

Step 4 Log in to the SmartLogger WebUI.

1. In the address box of a browser, enter **https://XX.XX.XX.XX** (XX.XX.XX.XX is the IP address of the SmartLogger) and press **Enter**. The login page is displayed.

If you log in to the WebUI for the first time, a security risk warning is displayed. Click **Continue to this website** to log in to the WebUI.

NOTE

- It is recommended that users use their own certificates. If the certificate is not replaced, the security risk warning will be displayed during each login.
- After logging in to the WebUI, you can import a certificate under **Maintenance > Security Settings > Network Security Certificate**.
- The imported security certificate needs to be bound to the SmartLogger IP address. Otherwise, the security risk warning will still be displayed during login.
- If an error message "ERR_INSUFFICIENT_RESOURCES" is displayed for the browser during login, the browser resources are insufficient. Clear the cache and restart the browser.
- If an error message "ERR_CONNECTION_TIMED_OUT" is displayed for the browser during login, perform the following troubleshooting operations:
 - Check whether the browser proxy is abnormal. If yes, set the browser proxy according to step 3.
 - Check whether the IP address of another device conflicts with that of the SmartLogger. If yes, assign a new IP address.

Figure 10-2 Security risk warning

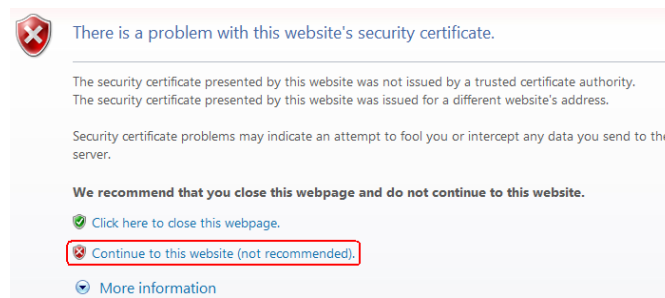

2. Select a desired language.
3. Select **User Name** and enter **Password** according to the following table, and then click **Log In**.

If...	Then...
On the login page, User Name is admin by default.	<ol style="list-style-type: none"> 1. Enter the initial password Changeme in Password and click Log In. 2. Change the initial password as prompted and use the admin user name and new password to log in again.
On the login page, User Name is empty by default.	Select installer in User Name , set the login password as prompted, and click Log In .

 **NOTE**

- Update the SmartLogger software as required.
 - To ensure account security, protect the password by changing it periodically, and keep it secure. Your password might be stolen or cracked if it is left unchanged for extended periods. If you lose the password, the device must be restored to its factory settings. In these cases, the Company shall not be liable for any loss caused to the plant.
 - You will be locked out for 10 minutes after five consecutive failed password attempts in 5 minutes.
 - A dialog box with recent login information is displayed after login. Click **OK**.
 - If the password of a non-administrator account is lost, you must reset the password using an administrator account. The administrator resets the password and enters the initial password. The non-administrator user logs in to the system using the initial password provided by the administrator. After the login, the user is forced to change the password.
 - If the password of an administrator account is lost, hold down the RST button on the SmartLogger for 10–20s to enter the safe mode. After the SmartLogger enters the safe mode, the device parameter settings are retained. Personal privacy and sensitive data, including login passwords and email addresses, will be deleted. SmartLogger V300R023C00 and later versions support this function.
4. Choose **Monitoring > Logger(Local) > About** to view the SmartLogger software version and check whether software upgrade is needed.

5. (Optional) To upgrade the SmartLogger software version, contact the Company's engineers to obtain the upgrade package and guide and complete the upgrade accordingly.

 **NOTE**

- After the software upgrade is complete, the SmartLogger automatically restarts. Log in to the SmartLogger WebUI again 3 minutes later.
- If the SmartLogger is upgraded from V300R001C00 to V800R021C00, the original administrator **admin** becomes an advanced user, and the login password remains unchanged. If administrator rights are required, log in to the SmartLogger as **installer**. The password is the same as that for logging in to the mobile app. If the SmartLogger is upgraded from V800R021C00 to V300R023C00, the login passwords of the advanced user **admin** and administrator **installer** remain unchanged.
- If the SmartLogger is upgraded from V300R001C00 to V300R023C00, the original administrator **admin** becomes an advanced user, and the login password remains unchanged. If administrator rights are required, log in to the SmartLogger as **installer** and set the login password as prompted.

----End

Follow-up Procedure

If any page is blank or a menu cannot be accessed after you log in to the WebUI, clear the cache, refresh the page, or log in again.

10.2 Checking the SmartLogger Software Version

Choose **Monitoring > Logger(Local) > About** and check that the software version is the same as the latest version in [FusionSolar Software Download](#).

Figure 10-3 Checking the version

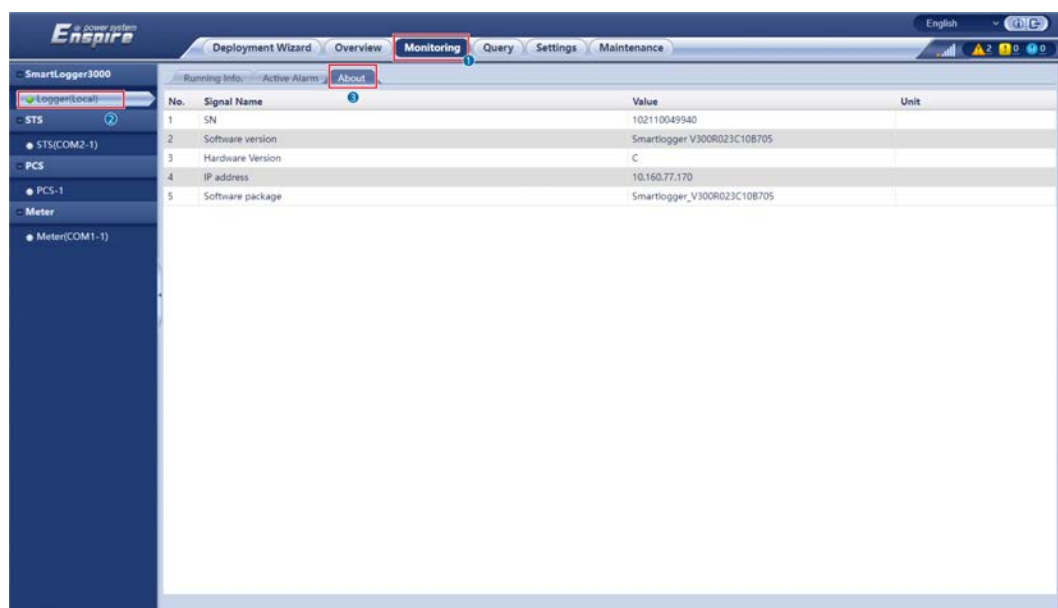

10.3 Upgrading the SmartLogger

NOTE

- If the SmartLogger software version is not the latest version in [FusionSolar Software Download](#), upgrade the SmartLogger and ensure that the SmartLogger software version matches the ESM software version.
- Obtain the SmartLogger upgrade package from the Company.

Step 1 Choose **Maintenance > Software Upgrade**, upload the SmartLogger upgrade package, select the device, and upgrade the SmartLogger.

Figure 10-4 Upgrading the SmartLogger

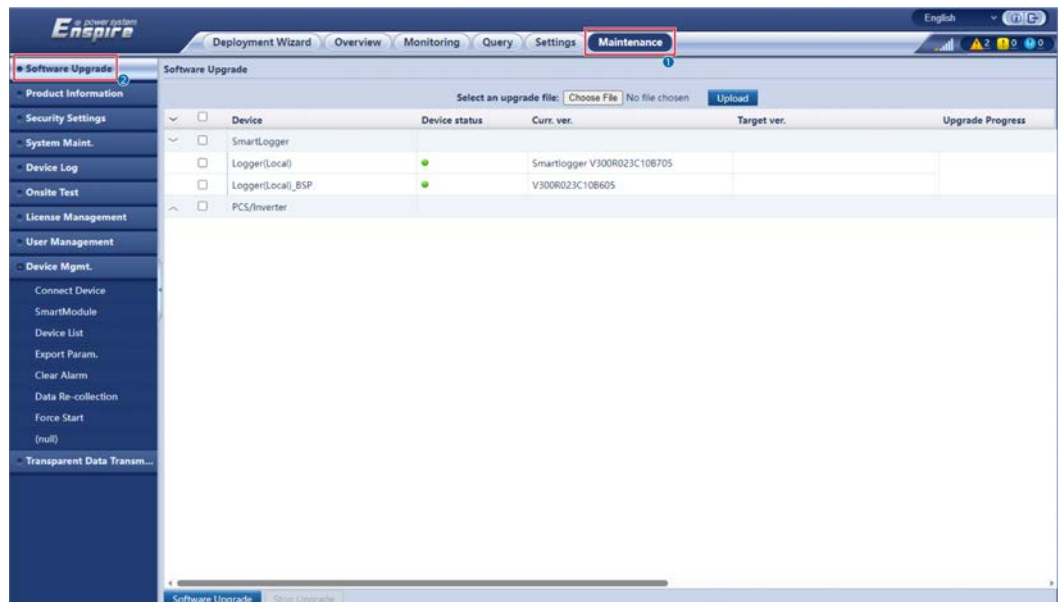

Step 2 After the software upgrade is complete, the SmartLogger automatically restarts. Log in to the SmartLogger WebUI again 2 minutes later.

----End

10.4 Upgrading the ESS

Step 1 Choose **Monitoring > ESU > Running Info.**, click  in the upper right corner, and wait for 2 minutes.

Step 2 Choose **Monitoring > ESR**, click +, and check that all ESM status indicators under the ESR are green or yellow.

NOTE

The quantity of ESMs displayed must be the same as the actual quantity of installed battery packs.

Figure 10-5 Checking the status



Step 3 Choose **Monitoring** > **ESR** > **Running Param.** > **Setting** and set **Quantity of battery packs** to the actual quantity of installed battery packs.

Table 10-1 Setting the quantity of battery packs

ESS	Quantity of Battery Packs
LUNA2000-97KWH-1H1	6
LUNA2000-129KWH-2H1	8
LUNA2000-161KWH-2H1	10
LUNA2000-200KWH-2H1	12

Figure 10-6 Setting the quantity of battery packs

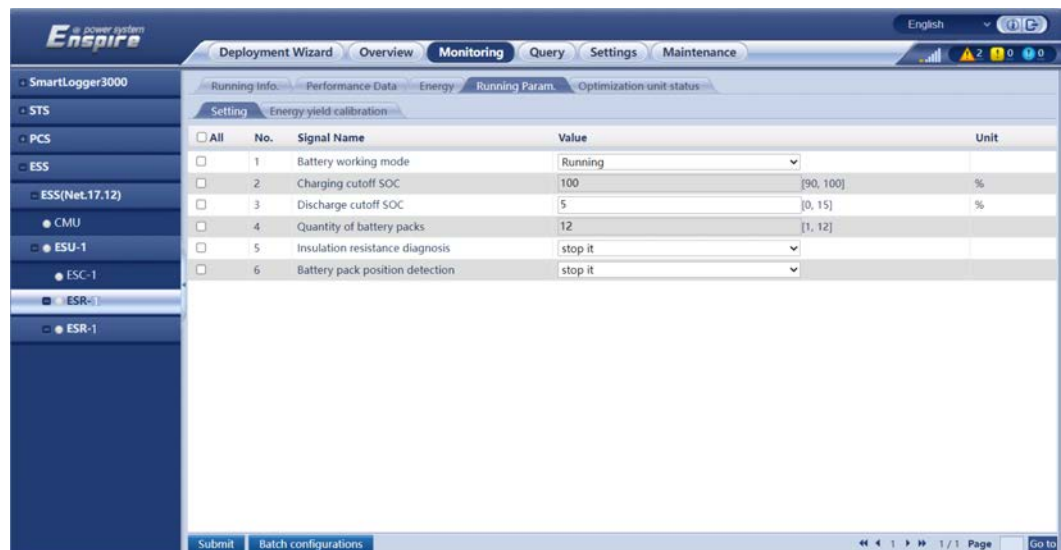

Step 4 Choose **Monitoring** > **ESM** > **About** and check all ESM software versions.

Figure 10-7 Checking the ESM software version

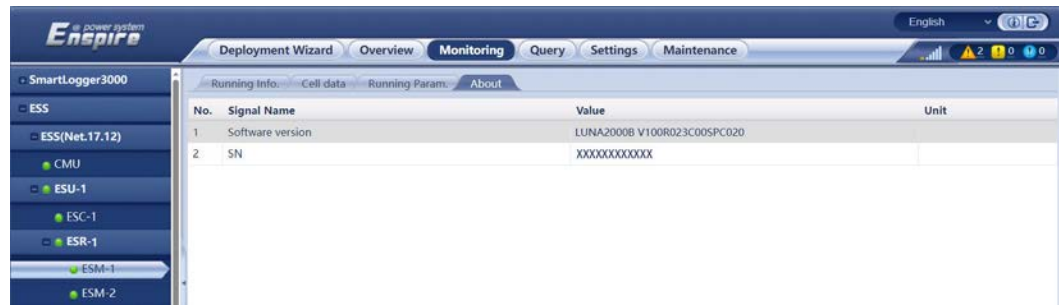

NOTE

- If the software version of an ESM is not the latest version in [FusionSolar Software Download](#), upgrade the ESS and ensure that the ESM software version matches the SmartLogger software version.
- If an alarm **Version Inconsistent Between Rack Controller and Battery Packs** or **Version Incompatible Between Rack Controller and Battery Packs** is generated, upgrade the ESS.
- Obtain the upgrade package from the Company.

Step 5 Choose **Maintenance > Software Upgrade**, upload the upgrade package, select the CMU, CMU_BSP, and ESU, and upgrade the software.

NOTE

Before upgrading the ESS, choose **Monitoring > ESS > ESU > Running Param.**, and check whether **Enable delayed upgrade** is set to **Disable**. If no, set it to **Disable**.

Figure 10-8 Upgrading the ESU

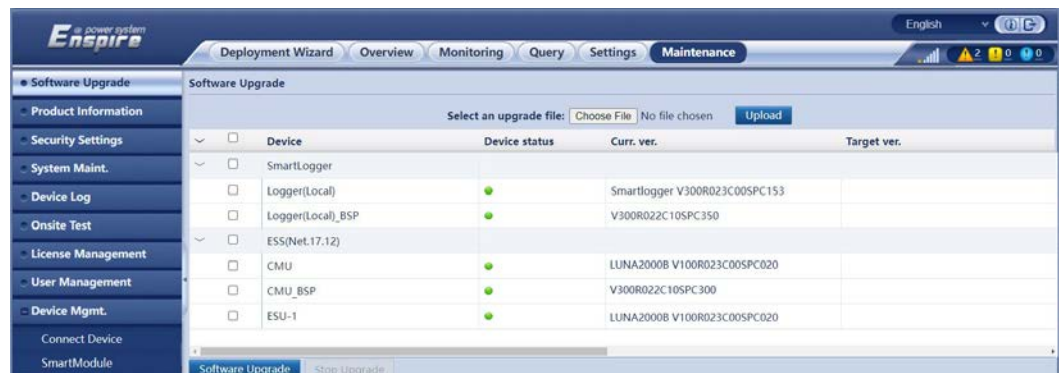

Step 6 Choose **Monitoring > ESM** and check  in the upper right corner to ensure that no major alarm is generated.

----End

10.5 System Startup

Context

Start up the system when needed.

Procedure

Step 1 On the SmartLogger WebUI, choose **Maintenance > Device Mgmt. > Connect Device**.

Step 2 Click  in the upper right corner to start devices in batches.

Figure 10-9 System startup

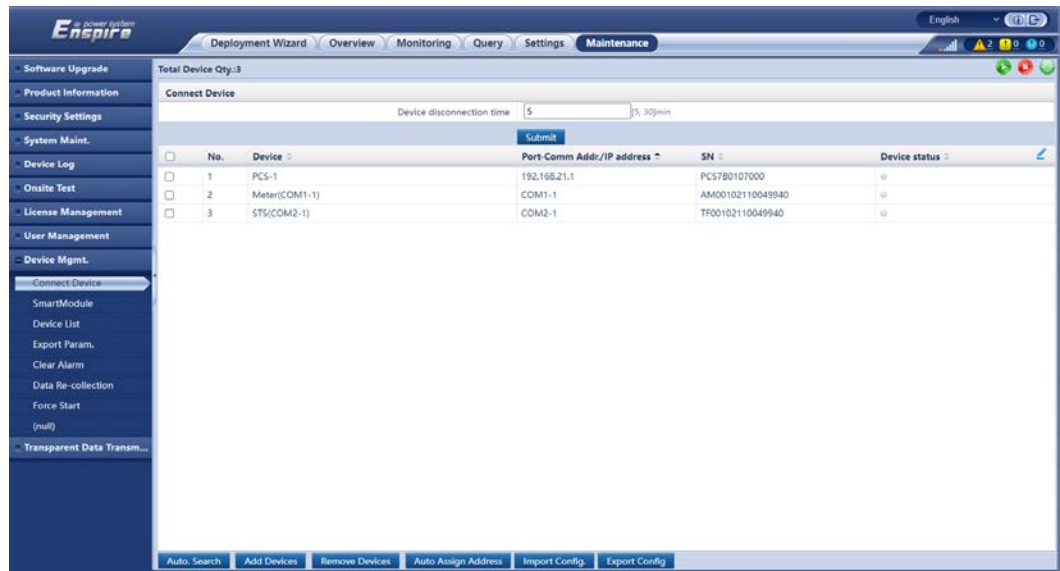

----End

10.6 Deployment Wizard

NOTE

During parameter setting, click **Previous**, **Next**, or **Skip** as required.

Step 1 Log in as **installer** to access the deployment wizard page.

Step 2 Click **Deployment Wizard** and set basic parameters.

- Set basic parameters.

Figure 10-10 Setting basic parameters

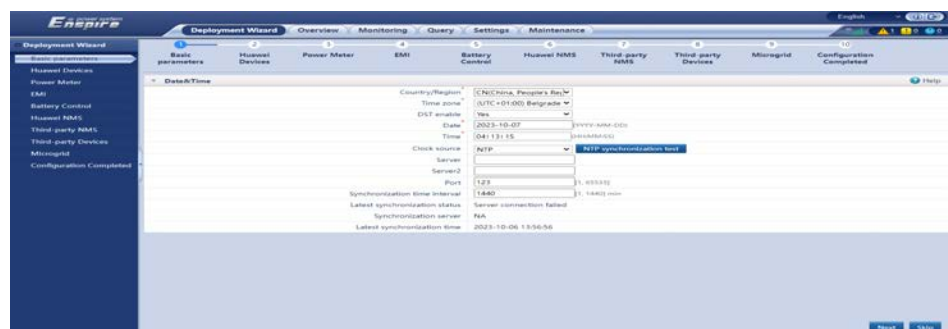

- Select a communication mode based on site requirements.

Step 3 Connect to Huawei devices.

- Click **Search for Device** to check the cable connections and allocate addresses.

Figure 10-11 Searching for devices



NOTE



- During the process of **Search for Device**, do not perform upgrade operations (such as upgrading through the app, management system, or WebUI).
 - When you click **Search for Device**, cable connections (DC and AC) will be checked before device search (not applicable to third-party devices), and device addresses will be automatically allocated.
 - After the cable connection check and device search are complete, if a cable connection alarm is generated, you can click the alarm icon  to view the corresponding alarm information.
 - If an alarm is generated when the cable connection check fails, click the alarm icon  to view the alarm cause and handling suggestions. After the fault is rectified, check the cable connections again.
 - After the cable connection check and device search are complete, click  to view the corresponding topology information.
 - After a device is added or deleted, you need to click **Search for Device** again in **Deployment Wizard**. Otherwise, the system topology will not be updated.
- Set parameters such as **Microgrid compatibility** and **Grid Code**.

Table 10-2 Parameter settings after device search (for versions earlier than SmartLogger V300R023C10)

Parameter	Description
Running under Grid connection state	Set this parameter only for the PCS, but not for the SUN2000. <ul style="list-style-type: none"> - In the on-grid scenario, set this parameter to On-grid(PQ). - In the off-grid scenario, set this parameter to Off-grid(VSG).
Microgrid compatibility	<ul style="list-style-type: none"> - In the on-grid scenario, set this parameter to Disable. - In the off-grid scenario, set this parameter to Enable.
Grid Code	Set the grid code of the country or region where the devices are used.

NOTICE

For PCSs on the same DC bus, ensure that the settings of **Running under Grid connection state** and **Microgrid compatibility** are the same.

Table 10-3 Parameter settings after device search (SmartLogger V300R023C10 and later versions)

Parameter	Description
Scenario under Arrays Operation Scenario	<ul style="list-style-type: none"> - In the on-grid scenario, set this parameter to On-grid. - In the off-grid scenario, set this parameter to Off-grid. - In the on/off-grid switchover scenario, set this parameter to On/Off-grid.
Grid Code	Set the grid code of the country or region where the devices are used.
Working mode under Parameter Configuration	<ul style="list-style-type: none"> - Set this parameter to PQ for the current source mode. - Set this parameter to VSG for the voltage source mode.

Parameter	Description
Microgrid compatibility under Parameter Configuration	<ul style="list-style-type: none"> In the on-grid scenario, set this parameter to Disable. In the off-grid scenario, set this parameter to Enable.
Active Power Baseline (kW) under Parameter Configuration	Set the lower limit of the maximum apparent power, which is also used as the baseline for active power scheduling.
Apparent Power Baseline (kVA) under Parameter Configuration	Set the upper limit of the maximum active power, which is also used as the baseline for reactive power scheduling.
Maximum Overload Active Power (kW) under Parameter Configuration	Set the maximum overload active power for grid forming.
Maximum Overload Apparent Power (kVA) under Parameter Configuration	Set the maximum overload apparent power for grid forming.

NOTICE

For PCSs on the same DC bus, ensure that the settings of **Scenario** under **Arrays Operation Scenario** and **Microgrid compatibility** are the same.

Step 4 Connect to a power meter, and set **Meter usage** to **Export+import meter**.

Figure 10-12 Setting meter parameters

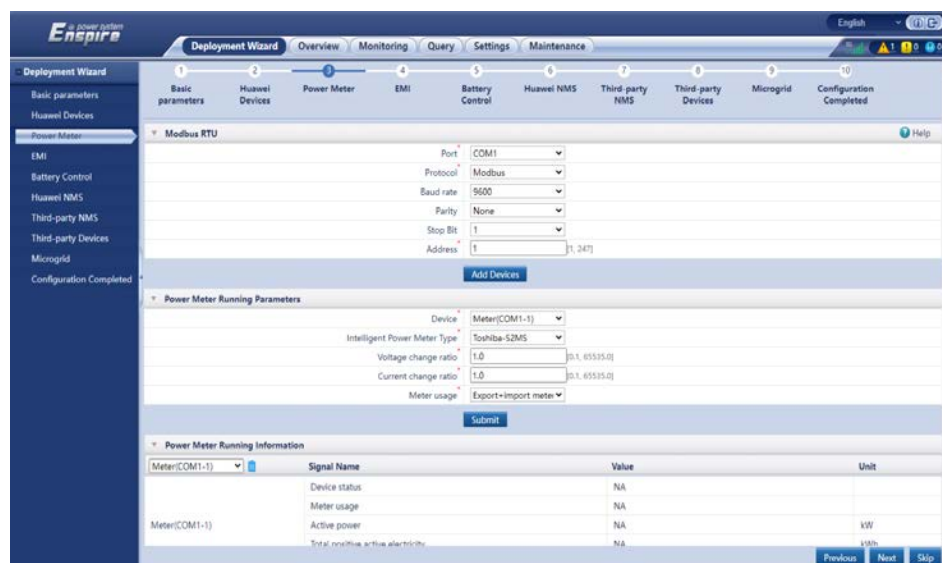

Step 5 Connect to EMIs.

Figure 10-13 Setting EMI parameters

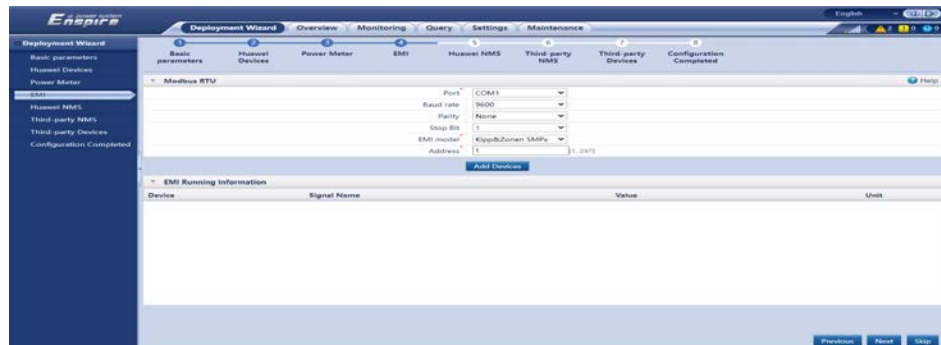

Step 6 Set battery control.

- Set the battery control working mode.

Table 10-4 Battery control working modes

Working Mode	Mode Description
No control	The SmartLogger directly delivers the external scheduling power limit. No other power scheduling control is performed. The power is automatically controlled by the device.
Maximum self-consumption	<ul style="list-style-type: none"> – This mode applies to areas where the electricity price is high, or areas where the FIT subsidy is low or unavailable. This mode is recommended when the PV +ESS system generates sufficient PV energy for loads and uses the surplus PV energy to charge the ESS (if the PV energy is insufficient to charge loads, the TOU mode is recommended). – PV energy is preferentially supplied to loads, and then the surplus PV energy is charged to the ESS. If the ESS is fully charged or is being charged at full power, the surplus PV energy is fed to the grid. When PV energy is insufficient or no PV energy can be generated at night, the ESS discharges energy to loads. This improves the self-consumption rate and energy self-sufficiency rate, and reduces electricity costs. The grid cannot charge the ESS. – The SmartLogger performs ESS scheduling based on the external scheduling power limit and the preceding policies.

Working Mode	Mode Description
<p>TOU</p>	<ul style="list-style-type: none"> - This mode applies to the PV+ESS system and ESS-only system where electricity prices at peak and off-peak hours are different and power meters are available. - You can manually set the charge and discharge time segments. For example, if you set the low electricity price period at night as the charge time, the system charges the ESS at the maximum power during the charge time. If you set the high electricity price period as the discharge time, the ESS can discharge energy only during the discharge time based on the actual load power, reducing electricity costs. - Click Add to set the charge and discharge time segments. A maximum of 14 time segments can be set. During the charge time, the grid can charge the ESS. During the discharge time, the ESS can supply energy to the loads. In other time segments, the ESS does not discharge energy. The PV system and grid supply energy to loads, and the PV system can charge the ESS. (In on/off-grid mode, if the grid fails, the ESS can discharge energy at any time.) - In some countries, the grid is not allowed to charge the ESS. In this case, this mode cannot be used. - The SmartLogger performs ESS scheduling based on the external scheduling power limit and the preceding policies.
<p>TOU (fixed power)^[1]</p>	<ul style="list-style-type: none"> - This mode applies to the PV+ESS system and ESS-only system where electricity prices at peak and off-peak hours are different and power meters are unavailable. - You can manually set the charge and discharge time segments. For example, if you set the low electricity price period at night as the charge time, the system charges the ESS at the fixed power during the charge time. If you set the high electricity price period as the discharge time, the ESS can discharge only during the discharge time at the fixed power, reducing electricity costs. - Click Add to set the charge and discharge time segments. A maximum of 14 time segments can be set. During the charge time, the grid can charge the ESS. During the discharge time, the ESS can supply energy to the loads. In other time segments, the ESS does not support charge or discharge. - In some countries, the grid is not allowed to charge the ESS. In this case, this mode cannot be used. - The SmartLogger performs ESS scheduling based on the external scheduling power limit and the preceding policies.

Working Mode	Mode Description
Charge/ Discharge based on grid dispatch	<ul style="list-style-type: none"> - This mode applies to utility-scale plant scheduling scenarios where a third-party controller delivers active power scheduling commands. - The purpose of scheduled discharge is to meet the active power scheduling target value at the grid connection point. PV energy is preferred. If the generated PV energy is insufficient, the ESS discharges energy and the energy is fed to the grid based on the active power scheduling target value. If the generated PV energy is sufficient, the energy is fed to the grid based on the active power scheduling target value, and the surplus PV energy is used to charge the ESS. - The purpose of scheduled charge is to meet the active power scheduling target value at the grid connection point. If the ESS charge power is insufficient or the Smart PCS limits the power, the grid charges the ESS with the maximum capability. If the ESS is not fully charged when the scheduling target value is met, the PV energy is used to charge the ESS.
<p>Note [1]: You can set this parameter in SmartLogger V300R023C00SPC150 and later versions.</p>	

Table 10-5 Running parameters in each ESS control working mode

Working Mode	Parameter	Description
Maximum self-consumption	Active power threshold of grid during battery discharge	Set the grid power threshold at the grid connection point for loads when the load power is greater than the PV power.
	Adjustment deadband	Set the precision of the grid power at the grid connection point. This parameter affects the power value range at the grid connection point. If the actual grid power threshold at the grid connection point is within this range, i.e. [Active power threshold of grid during battery discharge - Adjustment deadband, Active power threshold of grid during battery discharge + Adjustment deadband], the grid power requirement at the grid connection point is met.

Working Mode	Parameter	Description
	Adaptive adjustment parameters^[1]	Set the adjustment period and step parameters for raising the inverter power. <ul style="list-style-type: none"> - Enable: The adjustment period and step set in the SmartLogger are used. Generally, the adjustment period and step are calculated based on the number of devices connected to the port and device specifications. - Disable: Use this value based on site requirements.
	Adjustment period^[1]	This parameter is displayed after Adaptive adjustment parameters is set to Disable . You can set this parameter based on site requirements. In this case, battery control is performed based on the preset period.
	PV adjustment step^[1]	This parameter is displayed after Adaptive adjustment parameters is set to Disable . You can set this parameter based on site requirements. In this case, the PV rise step for PV+ESS equalization is the preset value.
TOU	Preferred use of surplus PV power	<ul style="list-style-type: none"> - Charge: When the PV power is greater than the load power, the surplus PV energy is used to charge the ESS. After the maximum charge power is reached or the ESS is fully charged, the surplus PV energy is fed to the grid. - Fed to grid: When the PV power is greater than the load power, the surplus PV energy is preferentially fed to the grid. When the maximum output power of the device is reached, the surplus energy is used to charge the ESS. This setting is applicable to the scenario where the FIT is higher than the electricity price and the grid cannot charge the ESS.
	Maximum power for charging batteries from grid	Set the maximum power at which the grid charges the batteries.

Working Mode	Parameter	Description
	Active power threshold of grid during battery discharge	Set the maximum target grid power when the grid-connection point has zero power.
	Adjustment deadband	Set the allowed fluctuation of the target grid power for the grid-connection point.
	Adaptive adjustment parameters^[1]	Set the adjustment period and step parameters for raising the inverter power. <ul style="list-style-type: none"> – Enable: The adjustment period and step set in the SmartLogger are used. Generally, the adjustment period and step are calculated based on the number of devices connected to the port and device specifications. – Disable: Use this value based on site requirements.
	Adjustment period^[1]	This parameter is displayed after Adaptive adjustment parameters is set to Disable . You can set this parameter based on site requirements. In this case, battery control is performed based on the preset period.
	PV adjustment step^[1]	This parameter is displayed after Adaptive adjustment parameters is set to Disable . You can set this parameter based on site requirements. In this case, the PV rise step for PV+ESS equalization is the preset value.
	Start time	Set the start time and end time of charge and discharge. A maximum of 14 time segments can be set. You can set a cycle by week by clicking the buttons corresponding to Mon. through Sun. in the Repeat box. The buttons are blue by default, indicating being selected. After you click it, the button turns gray.
	End time	
Charge/Discharge		
Repeat		
TOU (fixed power)	Start time	Set the start time, end time, and power of charge and discharge. A maximum of 14 time segments can be set. You can set a cycle by week by clicking the buttons corresponding to Mon. through Sun. in the Repeat box. The buttons are blue by default, indicating being selected. After you click it, the button turns gray.
	End time	
	Charge/Discharge	
	Charge/Discharge power (kW)	

Working Mode	Parameter	Description
	Repeat	
Charge/ Discharge based on grid dispatch	Adaptive adjustment parameters^[1]	Set the adjustment period and step parameters for raising the inverter power. <ul style="list-style-type: none"> – Enable: The adjustment period and step set in the SmartLogger are used. Generally, the adjustment period and step are calculated based on the number of devices connected to the port and device specifications. – Disable: Use this value based on site requirements.
	Adjustment period^[1]	This parameter is displayed after Adaptive adjustment parameters is set to Disable . You can set this parameter based on site requirements. In this case, battery control is performed based on the preset period.
	PV adjustment step^[1]	This parameter is displayed after Adaptive adjustment parameters is set to Disable . You can set this parameter based on site requirements. In this case, the PV rise step for PV+ESS equalization is the preset value.
Note [1]: This parameter is added in SmartLogger V300R023C00SPC120 and later versions. This parameter is displayed and needs to be set only when the Smart PCS is connected.		

- Set the automatic calibration functions.

Parameter	Description
Automatic SOC calibration	<ul style="list-style-type: none"> - If this parameter is set to Enable, automatic charge and discharge calibration is allowed for battery racks. During calibration, the cut-off SOC settings will be ineffective and the response of the charge and discharge power may be impacted temporarily. <ul style="list-style-type: none"> ▪ On-grid scenario: Automatic charge calibration is allowed for battery racks. ▪ Off-grid scenario: Automatic discharge calibration is allowed for battery racks. - If this parameter is set to Disable, automatic charge and discharge calibration is not allowed for battery racks.
Automatic SOH calibration	<ul style="list-style-type: none"> - If this parameter is set to Enable, the ESS periodically calibrates the SOH rack by rack. During the calibration, the end-of-charge SOC and end-of-discharge SOC settings will be overridden. - If this parameter is set to Disable, automatic SOH calibration is disabled for battery racks.

- Set **PCS insulation resistance detection**.

Parameter	Description
Detection start time	<p>Set the start time of the PCS insulation resistance detection. The default value is 02:00.</p> <p>If a dialog box You are advised to change the insulation resistance detection time to the optimal time: XX:XX is displayed, you are advised to click Confirm and set Detection start time to the optimal time.</p>

Step 7 Connect to the Huawei NMS.

Figure 10-14 Huawei NMS

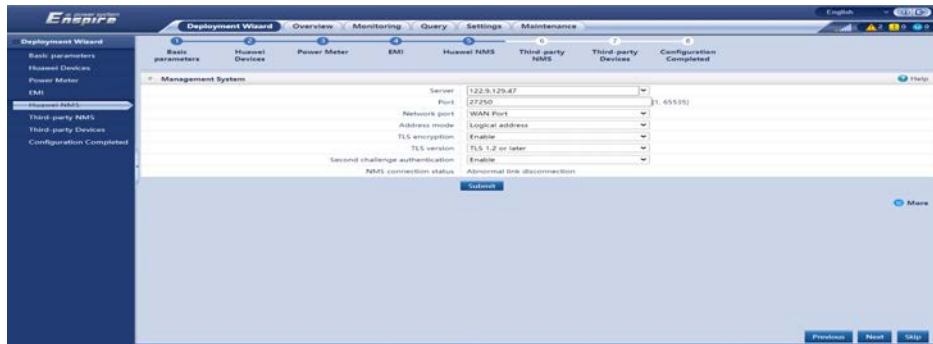

Step 8 Connect to a third-party NMS and select IEC104.

Figure 10-15 Connecting to a third-party NMS



Step 9 Connect to third-party devices.

Figure 10-16 Third-party devices

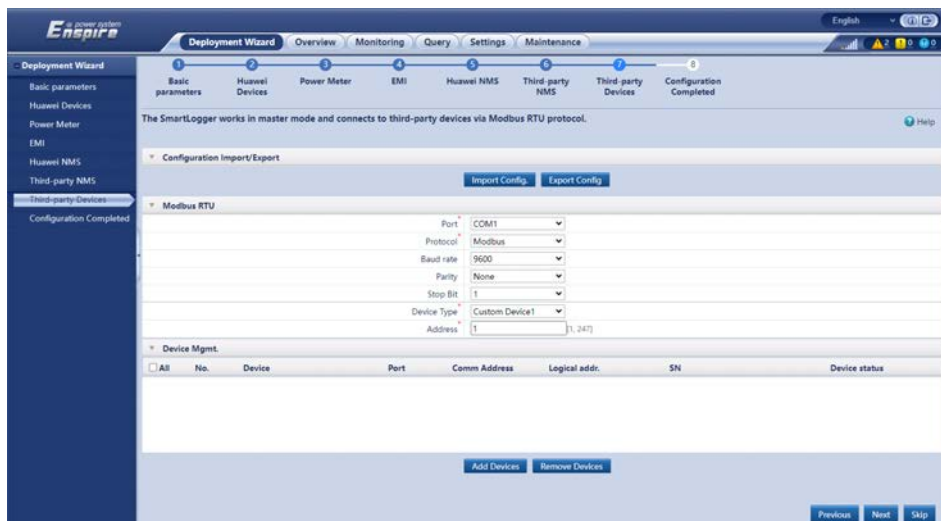

Step 10 The configuration is complete.

----End

10.7 Checking Alarms

Step 1 Check whether an alarm is generated on the SmartLogger WebUI or CMU WebUI. If an alarm is generated, handle the alarm by referring to the handling suggestions in the alarm reference section.

 NOTE

- You are advised to use the SmartLogger WebUI.
- If **Door Status Alarm** is generated, check whether the cabinet door is open. If yes, close the door.
- If **ESC Communication Failure** is generated, check whether communications cables are connected correctly and whether the power supply is normal.

Step 2 Short-circuit the water sensor and check whether a water alarm is generated on the SmartLogger WebUI or CMU WebUI:

- If a water alarm is generated, the water sensor is properly connected. In this case, the water alarm will be cleared after the short circuit is removed.
- If no water alarm is generated, check whether the water sensor cable is connected properly.

After the alarm is cleared, choose **Monitoring > Running Param. > Fire suppression > Starting up** on the SmartLogger WebUI or CMU WebUI.

Figure 10-17 Restoring the power supply

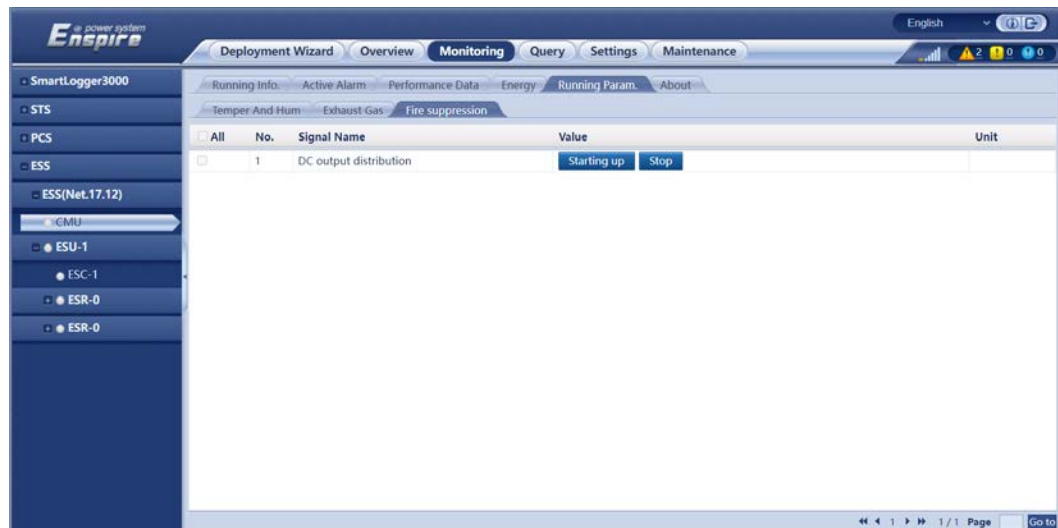

Step 3 Check whether an alarm is generated for the Smart Rack Controller on the SmartLogger WebUI or CMU WebUI. If an alarm is generated, handle the alarm by referring to the handling suggestions in the alarm reference section.

----End

10.8 Setting the System Antitheft Function

Context

The antitheft function is supported only in the LUNA2000B V100R023C00SPC120 and later versions and is used with SmartLogger V300R023C00SPC172 and later versions.

Procedure

Step 1 Choose **Monitoring > ESS > CMU** on the SmartLogger WebUI.

Step 2 Choose **Running Param. > Door Status Alarm** to set **Burglar Alarm**.

Parameter	Setting	Description
Burglar Alarm	Disable	No burglar alarm will be triggered when the ESS door is open.
	Enable	A burglar alarm will be triggered when the ESS door is open.

----End

11 Closing Cabinet Doors

After the deployment and commissioning are complete, close the cabinet doors and secure the safety rope.

Figure 11-1 Closing cabinet doors

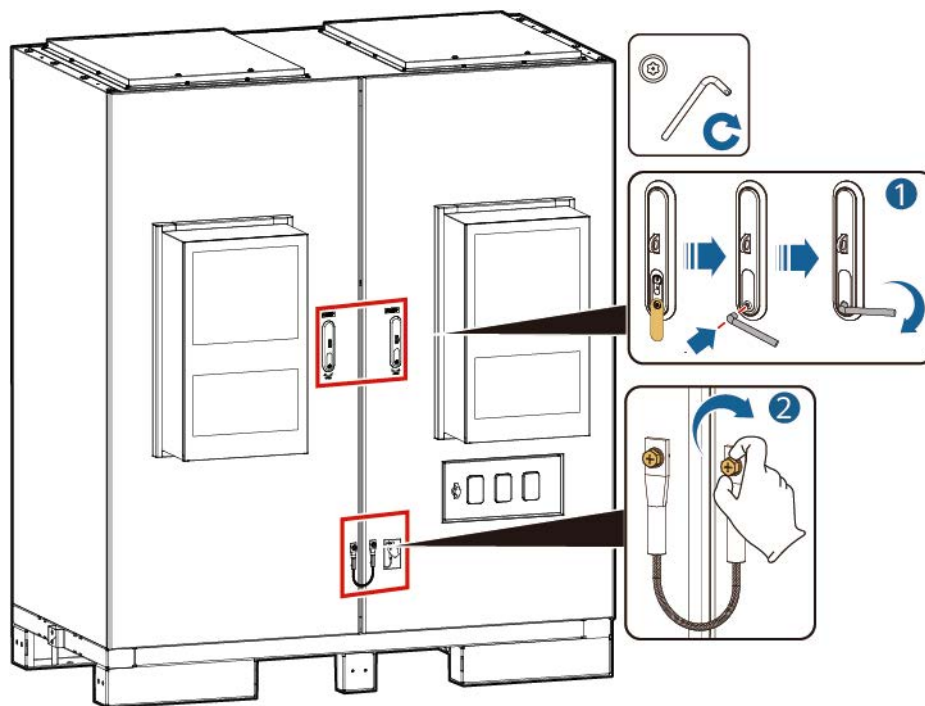

1803H00043

12 Powering Off the ESS

12.1 Sending a Shutdown Command on the SmartLogger

Prerequisites

The system has connected to the grid and is running properly.

Procedure

- Step 1** Log in to the SmartLogger WebUI, choose **Maintenance > Connect Device**, and click  to send a shutdown command to the Smart PCS and Smart Rack Controller.

Figure 12-1 Sending a shutdown command



- Step 2** Choose **Overview > Active Alarms** to view system alarms generated after the shutdown. If any alarm is generated, handle the alarm according to the alarm handling suggestions.

----End

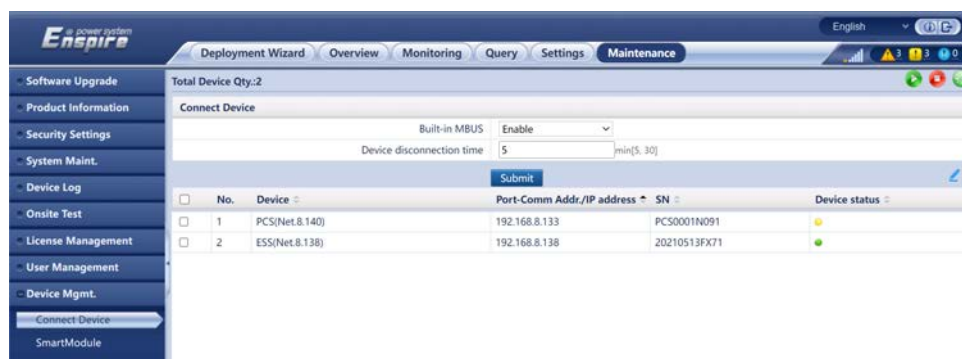
12.2 Power-Off Operations

Step 1 Turn off the DC switch 1Q2.

Step 2 Turn off all switches in the power distribution system of the ESS.

1. On the embedded power subrack (SK1), turn off the DC/DC switch 2FCB1, DC light power switch 2FCB2, TCUE switch 2FCB3, fan 1 switch 2FCB6, fan 2 switch 2FCB7, air conditioner 1 switch 2FCB8, and air conditioner 2 switch 2FCB9 in sequence.
2. (Optional) Turn off the 220 V maintenance socket switch 1FB1.
3. Turn off the PSU switch 1FCB2.
4. Turn off the 12 V adapter switch 1FCB1.

Step 3 Turn off the AC main switch 1FCB.

Step 4 (Optional) Turn off the UPS cable inlet switch 5FCB.

Step 5 Turn off the DC switch 1Q1.

Step 6 Turn off the switch between the AC side of the ESS and the power grid.

----End

13 Alarm Reference

For details about alarms, see the [LUNA2000-\(97KWH, 129KWH, 161KWH, 200KWH\) Series Smart String ESS Alarm Reference](#).

14 Technical Specifications

Technical Specifications	LUNA2000-200KWH-2H1	LUNA2000-161KWH-2H1	LUNA2000-129KWH-2H1	LUNA2000-97KWH-1H1
Single-cabinet rack controller configuration	One rack controller			
Single-cabinet battery configuration	12S1P	10S1P	8S1P	6S1P
Single-cabinet battery rated capacity	193.5 kWh	161.3 kWh	129.0 kWh	96.8 kWh
Charge and discharge rate	≤ 0.5C	≤0.64C	≤0.8C	≤1.0C
Intra-cabinet balancing mode	Battery pack-level active balancing			
Cabinet dimensions (H x W x D)	2135 mm x 1810 mm x 1200 mm			
Cabinet dimensions (including rack controller and Smart PCS, H x W x D)	2135 mm x 2570 mm x 1200 mm			
Net weight (including actual battery packs)	≤ 2950 kg	≤ 2690 kg	≤ 2430 kg	≤ 2170 kg
Net weight (excluding actual battery packs)	≤ 1070 kg	≤ 1090 kg	≤ 1110 kg	≤ 1130 kg
IP rating	IP55			
Operating temperature range	-30°C to +55°C			

Storage temperature range	-40°C to +60°C
Operating humidity range	0%–100% (non-condensing)
DC surge protection	Type II
Maximum operating altitude	4000 m
Battery temperature control mode	Industrial air conditioning
Fire suppression system	1 U fire suppression module (perfluorohexanone)
Auxiliary power supply	200–240 V AC, ≤ 4.2 kVA
System communications port	Ethernet/Optical fiber
System communications protocol	Modbus TCP
Environmental protection requirements	RoHS 6

A Crimping an OT or DT Terminal

Requirements on an OT or DT Terminal

- If a copper cable is used, use copper wiring terminals.
- If a copper-clad aluminum cable is used, use copper wiring terminals.
- If an aluminum alloy cable is used, use copper-to-aluminum wiring terminals, or aluminum wiring terminals along with copper-to-aluminum washers.

NOTICE

- Do not connect aluminum wiring terminals to the terminal block. Otherwise electrochemical corrosion may occur, affecting the reliability of cable connections.
 - Comply with the IEC 61238-1 requirements when using copper-to-aluminum wiring terminals, or aluminum wiring terminals along with copper-to-aluminum washers.
 - Do not mix up the aluminum and copper sides of a copper-to-aluminum washer. Ensure that the aluminum side of the washer contacts the aluminum wiring terminal, and that the copper side contacts the terminal block.
-

Figure A-1 Requirements on an OT or DT terminal

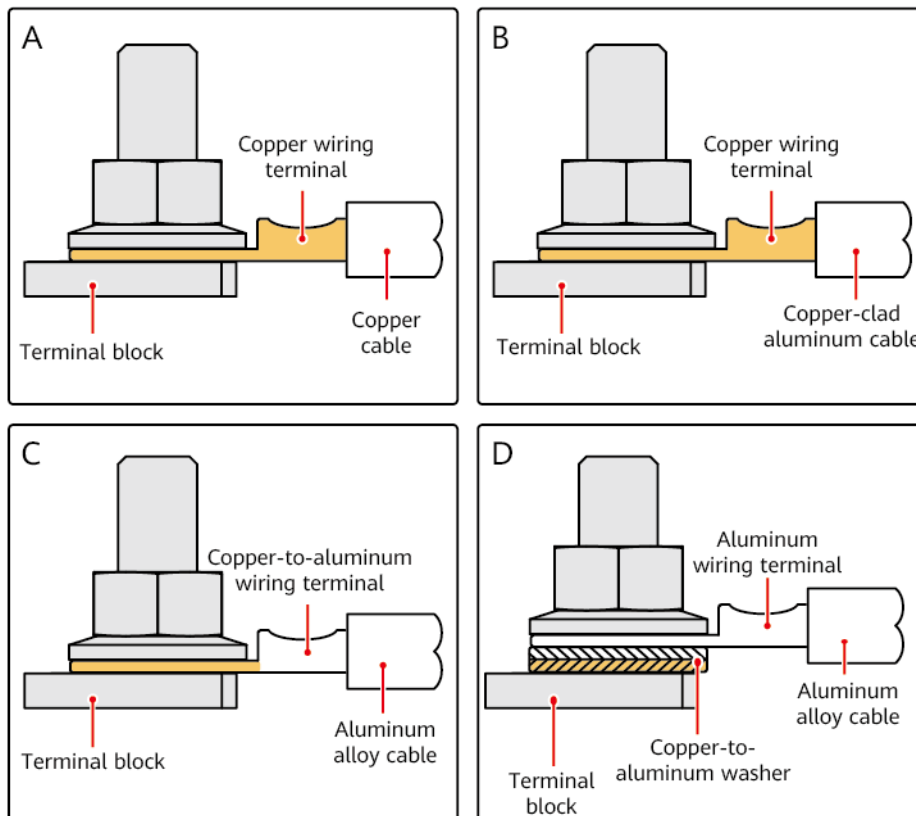

Crimping an OT or DT Terminal

NOTICE

- Avoid scratching the core wire when stripping a cable.
- The cavity formed after the conductor crimp strip of the OT or DT terminal has been crimped must wrap around the core wire completely. The core wire must make close contact with the OT or DT terminal.
- Wrap the wire crimping area with heat shrink tubing or insulation tape. The heat shrink tubing is used as an example.
- Use a heat gun carefully to avoid heat damage to the equipment.

Figure A-2 Crimping an OT terminal

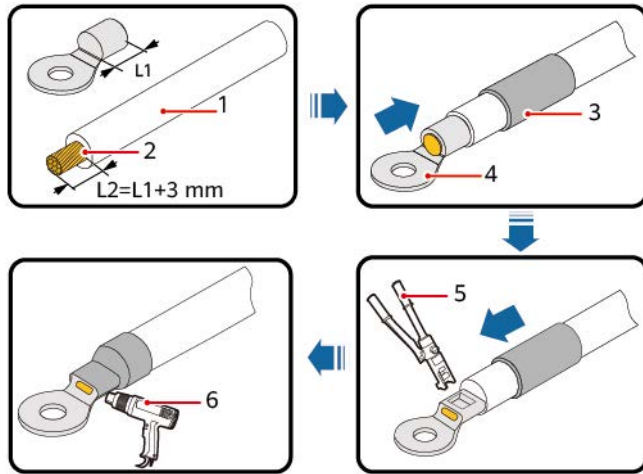

IS06Z00001

(1) Cable

(2) Core wire

(3) Heat shrink tubing

(4) OT terminal

(5) Hydraulic pliers

(6) Heat gun

Figure A-3 Crimping a DT terminal

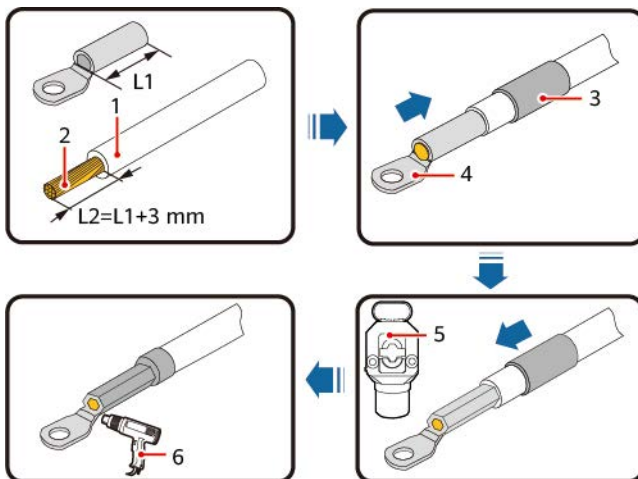

IP04I40001

(1) Cable

(2) Core wire

(3) Heat shrink tubing

(4) DT terminal

(5) Hydraulic pliers

(6) Heat gun

B How Do I Repair Paint Damage?

Prerequisites

- Do not apply paint in bad weather, such as rain, snow, strong wind, and sandstorm, when there is no shelter outdoors.
- You have prepared the required paint that matches the color palette delivered with equipment.

Paint Repair Description

The equipment appearance should be intact. If paint has flaked off, repair paint damage immediately.

NOTE

Check the paint damage on the equipment and prepare appropriate tools and materials. The number of materials depends on site requirements.

Table B-1 Paint repair description

Paint Damage	Tool and Material	Procedure	Description
Slight scratch (steel base material not exposed)	Spray paint or paint, brush (required for repainting a small area), fine sandpaper, anhydrous alcohol, cotton cloth, and paint spray gun (required for repainting a large area)	Steps 1, 2, 4, and 5	<ol style="list-style-type: none"> For a few scratches, smudges, or rust, manual paint spraying or brushing is recommended. For many scratches or large-area smudges and rusts, use a paint spray gun.
Smudges and rust that cannot be removed			
Deep scratch (primer damaged, steel base material exposed)	Spray paint or paint, zinc-rich primer, brush (required for repainting a small area), fine sandpaper, anhydrous alcohol, cotton cloth, paint spray gun (required for repainting a large area)	Steps 1, 2, 3, 4, and 5	<ol style="list-style-type: none"> The paint coating should be thin and even. Paint drops are prohibited on the coating. The surface should be smooth. Leave the repainted area for approximately 30 minutes before performing any further operation.
Logo and pattern damage	If a logo or pattern is damaged, provide the logo size and color number. Seek help from a local supplier of advertisement coatings to formulate a repair solution based on the logo size, color, and damage.		
Dent	<ol style="list-style-type: none"> If a dent is less than or equal to 100 mm² in area and less than 3 mm in depth, fill the dent with Poly-Putty base and then perform the same operations as those for processing deep scratches. If a dent is greater than 100 mm² in area or greater than 3 mm in depth, ask the local supplier for an appropriate repainting solution. 		

Procedure

Step 1 Gently polish damaged areas using fine sandpaper to remove smudges or rust.

Figure B-1 Polishing a damaged area using sandpaper

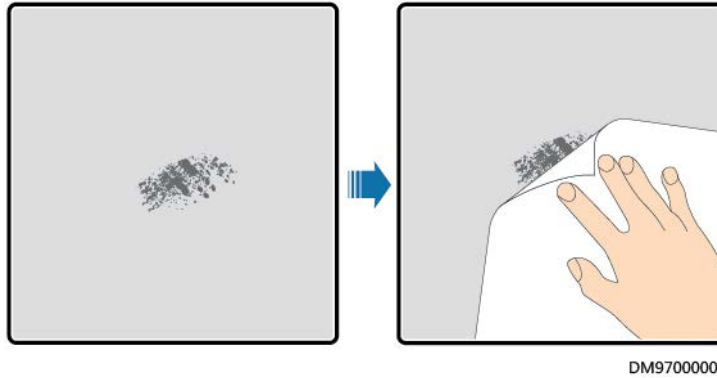

Step 2 Dip a piece of cotton cloth into anhydrous alcohol and wipe the polished or damaged area to remove the dirt and dust. Then wipe off the anhydrous alcohol with a clean and dry cotton cloth

Figure B-2 Wiping a polished or damaged area using anhydrous alcohol

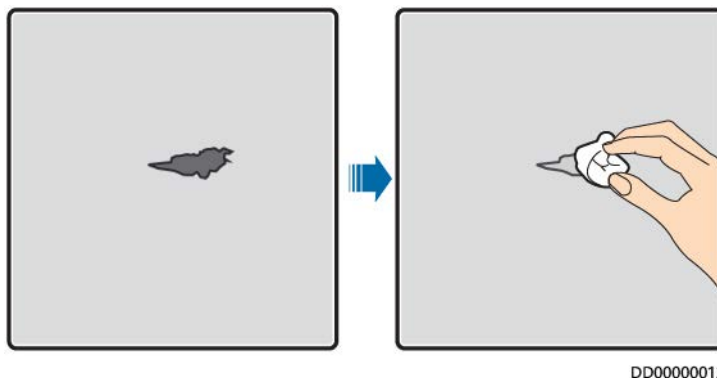

Step 3 Paint zinc-rich primer on the damaged coat using a brush or paint spray gun.

NOTICE

- If the base material is exposed in the area to be repaired, apply epoxy zinc-rich primer, wait until the paint has dried, and then apply acrylic acid top coat.
 - Select epoxy zinc-rich primer or acrylic acid top coat with a color the same as the surface coating color of the equipment.
-

Step 4 Apply paint evenly to the damaged area based on the damage degree of the paint using an aerosol spray, brush, or paint spray gun until all damage traces are invisible.

NOTICE

- Ensure that the painting is thin, even, and smooth.
- In the case that an equipment pattern has different colors, to prevent undamaged areas and those with different colors as the damaged area from being contaminated during repainting, cover such areas using white paper and adhesive tape before repainting.

Figure B-3 Repainting a damaged area

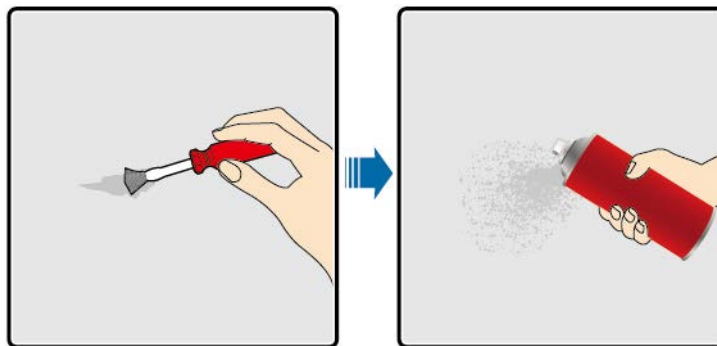

DD0000013

Step 5 Wait for 30 minutes and check whether the painting meets the requirements.

NOTE

- The color of the repainted area must be consistent with that of the surrounding area. Use a colorimeter to measure the color difference, which should be less than or equal to 3 ($\Delta E \leq 3$). If a colorimeter is unavailable, ensure that there is no visible edge between the repainted area and the surrounding area. The paint should be free of bulges, scratches, flaking, or cracks.
- If you choose to spray paint, it is recommended that you spray paint three times before checking the result. If the color does not meet the requirements, paint more times until the painting meets the requirements.

----End

Paint Supply Information

Table B-2 Paint requirements

Item	Requirement
Primer thickness	60 μm
Intermediate coat thickness	120 μm
Top coat thickness	60 μm
Primer type	Epoxy zinc-rich paint
Intermediate coat type	Zinc-rich paint

Item	Requirement
Color number of the top coat	Obtain the color number based on the color palette delivered with the product.

 **NOTE**

The following is a paint model list provided by the Company. The list may be updated from time to time and is for reference only. The cost of paint and technical services is subject to the local pricing standards.

Supplier	Position	Paint Model
Hempel	Equipment surface painting	Zinc-rich primer for pretreatment: HEMPADUR ZINC (shopprimer) 1536C/19830 Zinc-rich primer for the entire container: HEMPADUR ZINC (on line) 1536C/19830 Intermediate coat: HEMPADUR FAST DRY 15560/12170 Top coat: HEMPATHANE 55210/17630 (RAL9003)
	Logo	Red: HEMPATHANE 55210/57200 (RAL3020) Black: HEMPATHANE 55210-19990 (RAL9005)
CMP	Equipment surface painting	Zinc-rich primer for pretreatment: EPICON ZINC SC B-2 M (SHOP PRIMER) Zinc-rich primer for the entire container: EPICON ZINC SC B-2 M (ON LINE ZINC) Intermediate coat: EPICON SC PRIMER GREY CSC-9107 Top coat: UNYMARINE SC FINISH WHITE CSC-9205 (RAL-9003)
	Logo	Red: UNYMARINE SC MARKING RAL-3020 Black: UNYMARINE SC MARKING RAL-9005

C Emergency Handling

If an accident (including but not limited to the following) occurs on the site, ensure the safety of onsite personnel first and contact the Company's service engineers.

Battery Falling or Strong Impact

- If a battery has obvious damage or abnormal odor, smoke, or fire occurs, evacuate the personnel immediately, call emergency services, and contact the professionals. The professionals shall use fire extinguishing facilities to extinguish the fire under safety protection.
- If the appearance is not deformed or damaged, and there is no obvious abnormal odor, smoke, or fire, ensure safety and perform the following operations:
 - Warehouse: Evacuate personnel, transfer the battery to an open and safe place by professionals using mechanical tools, and contact the Company's service engineers. Leave the battery for an hour and ensure that the battery temperature is within the room temperature range (tolerance: $\pm 10^{\circ}\text{C}$) before handling.
 - ESS onsite: Evacuate personnel, close the doors of the ESS, transfer the battery to an open and safe place by professionals using mechanical tools, and contact the Company's service engineers. Leave the battery for an hour before handling.

Flood

- Power off the system if it is safe to do so.
- If any part of the batteries is submerged in water, do not touch the batteries to avoid electric shock.
- Do not use batteries that have been soaked in water. Contact a battery recycling company for disposal.

Fire

 DANGER

- If a fire occurs, power off the system if it is safe to do so.
 - Extinguish the fire with carbon dioxide, FM-200 or ABC dry powder fire extinguishers.
 - Ask firefighters to avoid contact with high-voltage components during fire fighting to prevent the risk of electric shock.
 - Overheating may cause battery deformation, faults, and leakage of corrosive electrolytes or toxic gases. Use respiratory protective equipment and keep a safe distance from the batteries to prevent skin irritation and chemical burns.
-

Fire Alarm Horn/Strobe

When the alarm indicator on the equipment blinks or buzzes:

- Do not approach.
- Do not open the door.
- Stay away immediately.
- Cut off the power supply remotely only when your safety is guaranteed.

Gas Exhaust

- Onsite personal protection: Do not directly face the exhaust vents.
- Post-disaster product maintenance: Contact the Company's service engineers for evaluation.

Extinguishant Release or Fire

- Suggestions for onsite O&M personnel:
 - a. When a fire occurs, evacuate from the building or equipment area, press the fire alarm bell, and immediately call the fire emergency service. Notify the professional firefighters and provide them with relevant product information, including but not limited to battery pack types, ESS capacity, and battery pack location and distribution.
 - b. Do not enter the affected building or equipment area under any circumstances, and do not open the doors of the ESS. Isolate and monitor the site. Keep irrelevant personnel away from the site.
 - c. After calling the fire emergency service, remotely power off the system (such as the Smart Transformer Station, Smart PCS, auxiliary power supply devices, and combiner box power supply) while ensuring your own safety.
 - d. After professional firefighters arrive, provide relevant product information, including but not limited to battery pack types, ESS capacity, battery pack location and distribution, and user manuals.
 - e. After the fire is extinguished, the site must be handled by professionals in accordance with local laws and regulations. Do not open the doors of the ESS without permission.

- f. Post-disaster product maintenance: Contact the Company's service engineers for evaluation.
- Suggestions for professional firefighters:
 - a. For product information, see the information provided by O&M personnel, including but not limited to battery pack types, ESS capacity, battery pack location and distribution, and user manuals.
 - b. Do not open the doors of the ESS before it is deemed safe by professionals.
 - c. Follow local fire fighting regulations.

D How Do I Recycle Used Batteries?

NOTICE

- The Company does not recycle batteries. Contact local recycling agencies to handle batteries.
- If there are no such agencies in your area, you can contact the nearest foreign recycling agencies.

Step 1 Contact the nearest recycling agency.

Step 2 Recycling agencies assess the costs.

Step 3 Recycling agencies carry out recycling, which can be done in two ways:

- Onsite recycling: Recycling agencies can visit your sites to recycle lithium batteries, but the price depends on actual conditions such as the distance and transportation expenses.
- Centralized recycling: You can collect all lithium batteries to be recycled in one place for the recycling agencies to handle.

NOTE

You need to cover the related transportation expenses.

Step 4 Recycling companies handle recycling. The recycled lithium batteries are at the disposal of the recycling companies.

----End

E CMU Commissioning

E.1 CMU Operations on the WebUI

E.1.1 CMU WebUI Operations

E.1.1.1 Introduction to the WebUI

NOTICE

- This document takes the WebUI screenshots of the LUNA2000B V100R023C00 for example. The screenshots are for reference only.
- The parameter names, value ranges, and default values are subject to change. The actual display may vary.













E.1.1.2 WebUI Layout





Figure E-1 WebUI layout



No.	Function	Description
1	First-level menu	Specifies the first-level menu for subsequent operations over the WebUI.
2	Second-level menu	Allows users to choose the device to be queried or the parameter to be set under the second-level menu.
3	Third-level menu	Allows users to choose a third-level menu to access the query or setting page.
4	Details page	Displays details of the queried information or parameter setting.
5	Display language	Allows users to select the display language or choose to log out.
6	Alarm icon	Displays the severities and number of active system alarms. You can click a number to access the alarm page.

E.1.1.3 Icon Description

Icon	Description	Icon	Description
	Click the About icon to query the WebUI version information.	 	Click the Drop-down icon to select a parameter or time.
	Click the Exit icon to log out.		Alarms are classified into major, minor, and warning ones. Click the Alarm icon to query an alarm.
	Click the Increase/Decrease icon to adjust time.		Click the Startup icon to start the device.
	The Select icon indicates that a parameter is selected.		Click the Stop icon to shut down the device.
	The Select icon indicates that a parameter is not selected. Click the icon to select a parameter.		Click the Reset icon to reset the device.
	Display icon and Hide icon.		The CMU is in Running state.

Icon	Description	Icon	Description
	<ul style="list-style-type: none"> The CMU is in Disconnection state. If the CMU is in Disconnection state, its parameters cannot be set. 		The CMU is in Loading state.
	The CMU is in Initializing, Power-off, Idle or other states in which the CMU is not feeding power into the grid.		Ascending order or descending order icon. Click the icon to sort the items in ascending or descending order for the corresponding column.

E.1.1.4 WebUI Menus

Table E-1 WebUI menus

First-Level Menu	Second-Level Menu	Third-Level Menu	Function
Overview	ESS information	-	Queries ESS information.
	Active Alarm	-	Queries active alarms.
	Performance Data	-	Queries or exports performance data.
Monitoring	CMU	Running Info.	Queries running information.
		Active Alarm	Queries active alarms.
		Running Param.	Sets running parameters.
		Module (M1)	Queries the expansion module.
		IO Board	Queries black-start information.
		About	Queries the version and communication information.
Query	Alarm History	-	Queries historical alarms.
	Operation Log	-	Queries operation logs.
	Export Data	-	Exports historical alarms, energy yields, operation logs, and power grid scheduling data.
Settings	User parameters	Date&Time	Sets the date and time.

First-Level Menu	Second-Level Menu	Third-Level Menu	Function
	Comm. Param.	Wireless Network	<ul style="list-style-type: none"> • Sets parameters for the built-in WLAN. • Sets mobile data (4G/3G/2G) parameters.
		Wired Network	Sets wired network parameters.
		RS485	Sets RS485 parameters.
		Modbus TCP	Sets Modbus TCP parameters.
	Other parameters	-	-
Maintenance	Software Upgrade	-	Upgrades the CMU software.
	Product information	-	Queries product information.
	Security Settings	-	<ul style="list-style-type: none"> • Changes the user password. • Sets the automatic logout time. • Uploads a network security certificate. • Updates the key. • Sets the lockout duration and number of times an account is locked upon login failure. • Sets the certificate alarm time. • Uploads a SmartModule security certificate. • Enables or disables communication using an expired SmartModule certificate.
	System Maint.	-	<ul style="list-style-type: none"> • Resets the system. • Restores the factory settings. • Clear data. • Exports all configuration files. • Imports all configuration files. • Clears cache.
	Device Log	-	Export device logs.
	Onsite Test	-	Performs a charge/discharge test on the battery rack.
	User Management	-	Adds, modifies, or deletes a user.
	Device Mgmt.	Connect Device	<ul style="list-style-type: none"> • Adds or removes a device. • Imports or exports configurations.

First-Level Menu	Second-Level Menu	Third-Level Menu	Function
		SmartModule	<ul style="list-style-type: none"> Removes the SmartModule. Sets the authentication password.
		Clear Alarm	Clears device alarms.

E.1.2 Maintenance Operations

E.1.2.1 Preparations and WebUI Login

Prerequisites

- The operating system of Windows 7 or a later version is supported.
- Browser: Chrome 52, Firefox 58, or Internet Explorer 9, or a later version is recommended.

Procedure

Step 1 Connect the network cable between the network port of the PC and the WAN or LAN port of the CMU.

Step 2 Set the IP address of the PC. Ensure that the IP address is in the same subnet as that of the CMU.

- Scenario where the CMU is not connected to the SACU

Connected Port	Item	CMU Default Value	Example PC Setting
LAN port	IP address	192.168.8.10	192.168.8.11
	Subnet mask	255.255.255.0	255.255.255.0
	Default gateway	192.168.8.1	192.168.8.1
WAN port	IP address	192.168.0.10	192.168.0.11
	Subnet mask	255.255.255.0	255.255.255.0
	Default gateway	192.168.0.1	192.168.0.1

- Scenario where the CMU is connected to the SACU

SACU LAN Port IP Address	CMU WAN Port IP Address	CMU LAN Port IP Address
192.168.8.10	192.168.8.XXX	192.168.3.10
XXX.XXX.XXX.XXX ^a	XXX.XXX.XXX.XXX ^a	192.168.8.10

SACU LAN Port IP Address	CMU WAN Port IP Address	CMU LAN Port IP Address
Note a: When you set the IP address of the SACU LAN port, the IP address of the CMU WAN port changes with the IP address of the SACU LAN port. You can view the IP address on the SACU WebUI or SUN2000 app.		

Step 3 Set LAN parameters.

NOTICE

- If the CMU is connected to a LAN and a proxy server has been configured, you need to cancel the proxy server configurations.
- If the CMU is connected to the Internet and the PC is connected to the LAN, do not cancel the proxy server configurations.

1. Open Internet Explorer.
2. Choose **Tools > Internet Options**.
3. Click the **Connections** tab and then click **LAN settings**.
4. Clear **Use a proxy server for your LAN**.

Figure E-2 LAN settings

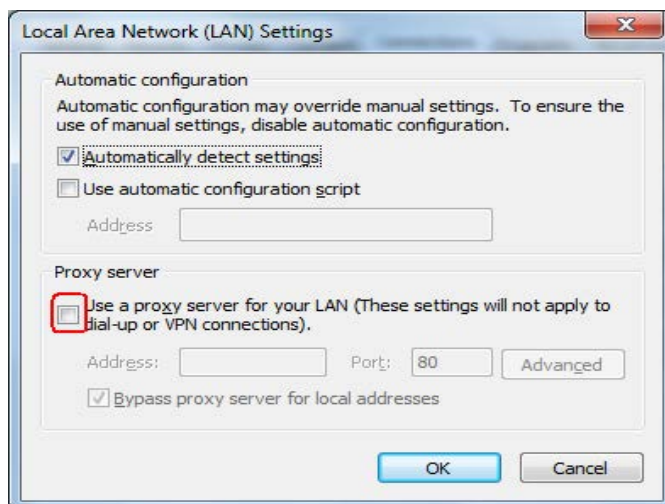

5. Click **OK**.

Step 4 Log in to the CMU WebUI.

1. In the address box of a browser, enter **https://XX.XX.XX.XX** (XX.XX.XX.XX is the IP address of the CMU) and press **Enter**. The login page is displayed.

If you log in to the WebUI for the first time, a security risk warning is displayed. Click **Continue to this website** to log in to the WebUI.

 **NOTE**

- It is recommended that users use their own certificates. If the certificate is not replaced, the security risk warning will be displayed during each login.
- After logging in to the WebUI, you can import a certificate under **Maintenance > Security Settings > Network Security Certificate**.
- The imported security certificate needs to be bound to the CMU IP address. Otherwise, the security risk warning will still be displayed during login.

Figure E-3 Security risk warning

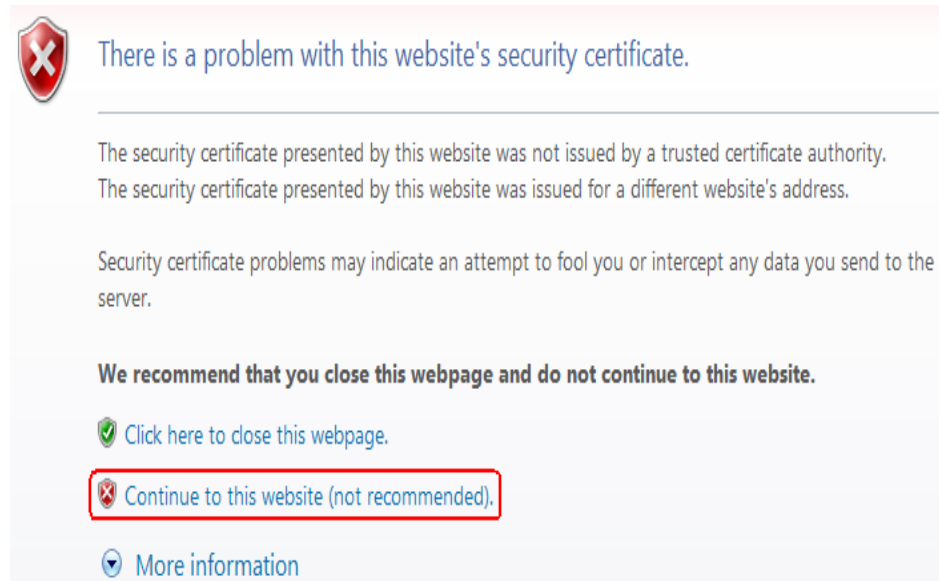

2. Specify **Language**, **User Name**, and **Password**, and click **Log In**.

Figure E-4 Login page (Initial login when the user name is displayed as admin)

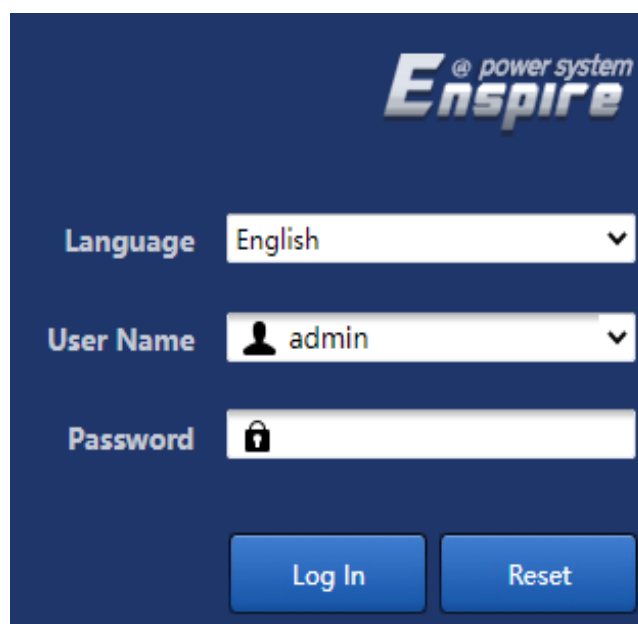

 **NOTE**

In this scenario, you need to update the software version to LUNA2000B V100R023C00 or later.

Parameter	Description
Language	Set this parameter as required.
User Name	Default value: admin
Password	<ul style="list-style-type: none">- The initial password is Changeme1234.- Use the initial password upon the first power-on and change it immediately after login. Then, use the new password to log in again.

 **NOTE**

Updating to LUNA2000B V100R023C00 or later:

- Method 1: Log in as **admin** using your new password.
- Method 2: Select **installer** as the user name and set the login password as prompted.

Figure E-5 Login page (Initial login when the user name is empty)

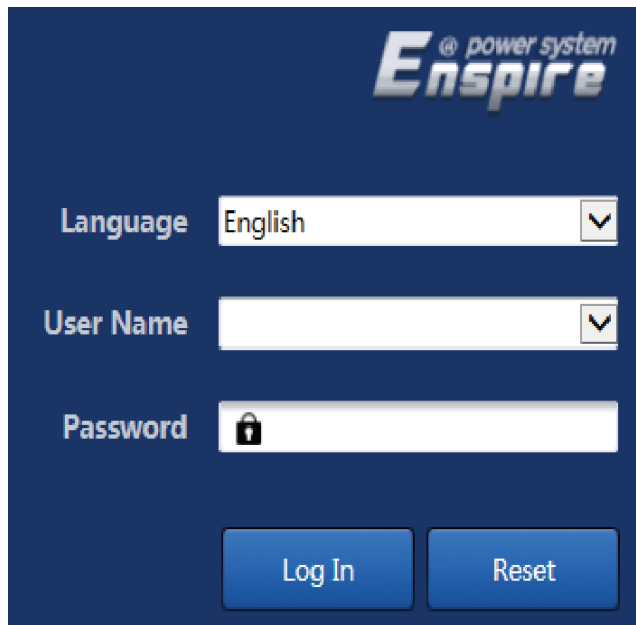

IL03J00002

 **NOTE**

In this scenario, the software version is LUNA2000B V100R023C00 or later.

Parameter	Description
Language	Set this parameter as required.
User Name	Log in as installer .
Password	Set the login password as prompted.

 **NOTE**

- To ensure account security, protect the password by changing it periodically, and keep it secure. Your password might be stolen or cracked if it is left unchanged for extended periods. If you lose the password, the device must be restored to its factory settings. In these cases, the Company shall not be liable for any loss caused to the plant.
- You will be locked out for 10 minutes after five consecutive failed password attempts in 5 minutes.
- A dialog box with recent login information is displayed after login. Click **OK**.

----End

Follow-up Procedure

If any page is blank or a menu cannot be accessed after you log in to the WebUI, clear the cache, refresh the page, or log in again.

E.1.2.2 Upgrading the Software Version

Prerequisites

- Before upgrade, check whether an ESU alarm is generated. If yes, clear the alarm by referring to the alarm handling suggestions and then perform the upgrade.
- Before upgrade, ensure that the SOC of the battery rack is greater than 30%. Otherwise, the delayed upgrade function may be triggered (only software is loaded without performing the upgrade).

Procedure

Step 1 Upgrade the software.

Figure E-6 Software upgrade

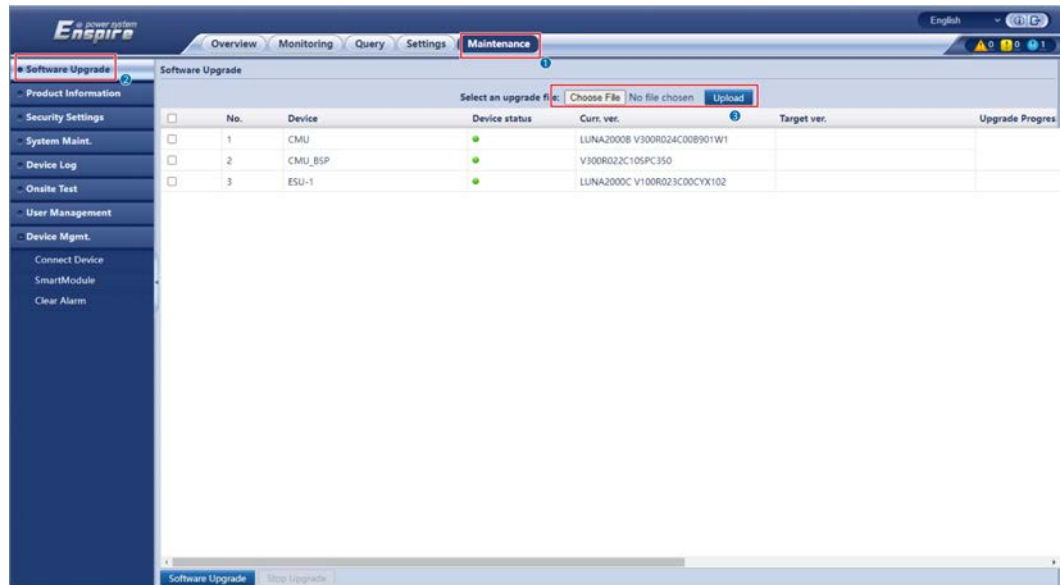

----End

 NOTE

- The **Stop Upgrade** function applies only to the devices waiting to be upgraded.
- If the system displays a message indicating that the loading is successful instead of the upgrade, the delayed upgrade function is triggered. The system automatically performs the upgrade when the conditions are met.
- If the upgrade fails, contact technical support.

E.1.2.3 Exporting Device Logs

Step 1 Access the device log page.

Figure E-7 Exporting logs

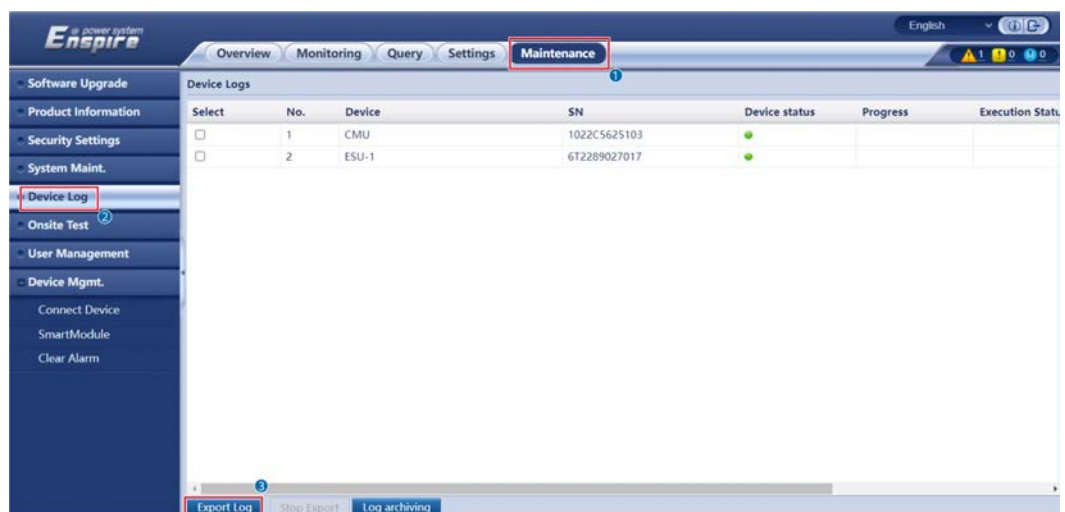

Step 2 Select the target device and click **Export Log**.

 **NOTE**

Logs can be exported for a maximum of six devices of the same type at a time.

Step 3 Observe the progress bar and wait until the log export is complete.

Step 4 After the export is successful, click **Log archiving** to save the logs.

----End

E.1.2.4 Checking Alarms

Step 1 Choose **Overview > Active Alarms**.

Figure E-8 Checking alarms

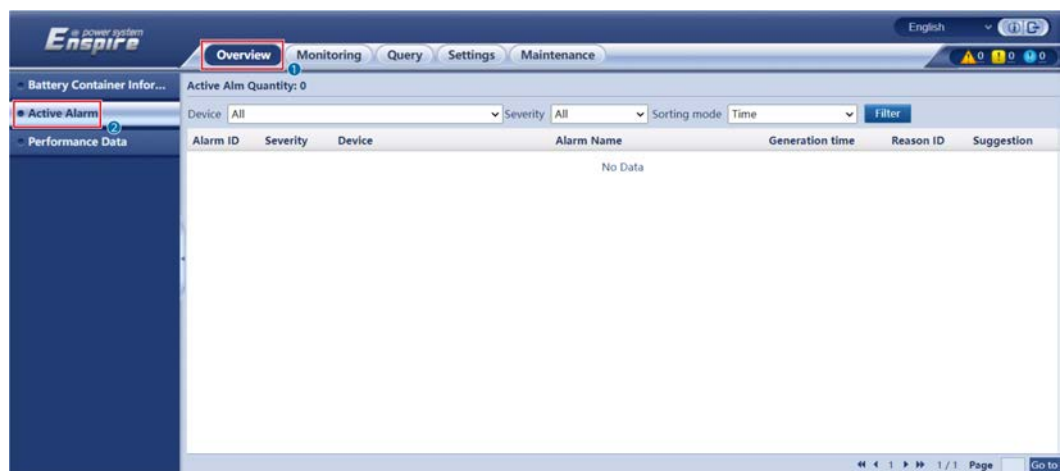

----End

E.1.2.5 Clearing Alarms

You can clear all active and historical alarms for the selected device and collect alarm data again.

Procedure

Step 1 Choose **Maintenance > Device Mgmt. > Clear Alarm**.

Figure E-9 Clearing alarms

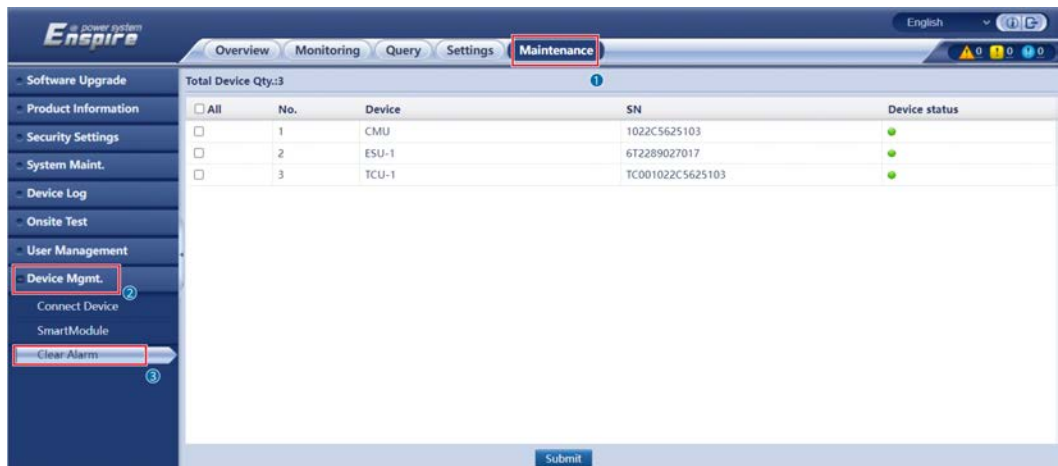

Step 2 Select the name of the device whose alarms are to be cleared, click **Submit**, and choose **All**, **Locally synchronized alarms**, or **Alarms stored on devices** to clear alarms.

----End

 **NOTE**

If alarms are cleared on the CMU, you must reset the alarm on the SmartLogger. Otherwise, the SmartLogger cannot obtain the alarm information collected by the CMU after the alarms are cleared.

E.2 App Operations

E.2.1 Downloading and Installing the App

SUN2000 app: Access Huawei AppGallery and search for **SUN2000**, or scan the following QR code (or directly visit <https://appgallery.cloud.huawei.com/appdl/C10279542>) to download and install the app.

QR code:



E.2.2 Logging In to the App

Prerequisites

- The CMU has been powered on.
- The WLAN function has been enabled on your phone.
- Keep the phone within 5 m of the CMU. Otherwise, the communication quality might be poor.

Procedure

Step 1 Press and hold the **RST** button for 1s to 3s to power on the CMU's built-in WLAN module.

 **NOTE**

- If the **ALM** indicator blinks green fast for 2 minutes and other indicators are off, the WLAN module is powered on.
- If the WLAN module is not connected to the app, the WLAN module is automatically powered off after being powered on for 4 hours.

Step 2 In the SUN2000 app, select a connection mode.

 **NOTE**

- The screenshots in this section correspond to the SUN2000 app 6.22.10.117 (Android).
- Use the initial password for the first login and change it immediately after login. To ensure account security, protect the password by changing it periodically, and keep it secure. Your password might be stolen or cracked if it is left unchanged for extended periods. If a password is lost, devices cannot be accessed. In these cases, the Company shall not be liable for any loss caused to the plant.

1. Tap **Manual connection** and select a product icon.

 **NOTE**

- The CMU has a built-in WLAN module. The initial name of the WLAN hotspot is **SN of the Monitor-CMU**, and the initial password is **Changeme**.
- If **Changeme** cannot be used for the first login, obtain the initial password from the QR code on the CMU.

Figure E-10 Manual connection

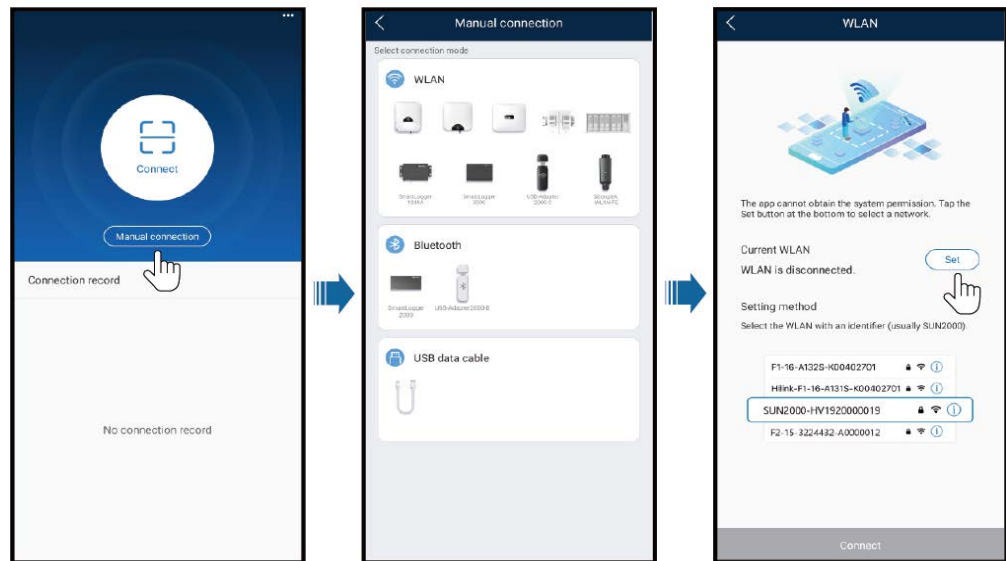

2. Tap **Connect** and scan the QR code on the CMU.

NOTE

Products delivered earlier do not support connection by scanning the QR code. In this case, manually connect the product.

- Step 3** Select the login user and enter the login password. The main menu screen is displayed.

NOTICE

- When you log in to the system for the first time, set the login password. To ensure account security, protect the password by changing it periodically, and keep it secure. Your password might be stolen or cracked if it is left unchanged for extended periods. If a password is lost, devices cannot be accessed. In these cases, the Company shall not be liable for any loss caused to the plant.
- For the same username, the password for logging in to the app is the same as that for logging in to the CMU WebUI.
- You will be locked out for 10 minutes after five consecutive failed password attempts in 5 minutes.

Figure E-11 Login

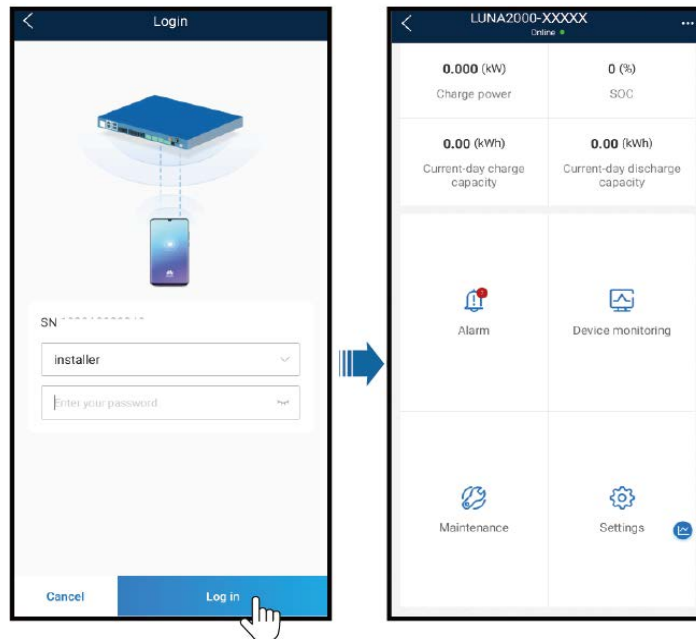

----End

E.2.3 Changing a Password

Changing the WLAN Hotspot Password of a Device

Log in to the app, choose **Settings** > **Communication settings** > **Device WLAN**, and change the WLAN hotspot password of the device.

Changing the Login Password of a User

After logging in to the app, tap  in the upper right corner of the screen, and choose **Change password** to change the login password.

F Certificate Management and Maintenance

Preconfigured Certificate Risk Disclaimer

The Huawei-issued certificates preconfigured on Huawei devices during manufacturing are mandatory identity credentials for Huawei devices. The disclaimer statements for using the certificates are as follows:

1. Preconfigured Huawei-issued certificates are used only in the deployment phase, for establishing initial security channels between devices and the customer's network. Huawei does not promise or guarantee the security of preconfigured certificates.
2. The customer shall bear consequences of all security risks and security incidents arising from using preconfigured Huawei-issued certificates as service certificates.
3. A preconfigured Huawei-issued certificate is valid from the manufacturing date until October 2041.
4. Services using a preconfigured Huawei-issued certificate will be interrupted when the certificate expires.
5. It is recommended that customers deploy a PKI system to issue certificates for devices and software on the live network and manage the lifecycle of the certificates. To ensure security, certificates with short validity periods are recommended.

Application Scenarios of Preconfigured Certificates

File Path and Name	Scenario	Replacement
/mnt/log/tcpmb_server_cert/ca.crt	Authenticates the validity of the peer mobile app for communication through Modbus-TCP.	Certificate replacement is not supported.
/mnt/log/tcpmb_server_cert/tomcat_client.crt		

File Path and Name	Scenario	Replacement
/mnt/log/smodule_ca.crt	Authenticates the validity of the peer BCU for communication with the BCU TLS.	
/mnt/log/smodule_server.crt		
/mnt/log/cmu_ca.crt	Authenticates the validity of the peer SACU for communication with the SACU through Modbus-TCP.	For details about how to replace a certificate, contact technical support engineers to obtain the corresponding security maintenance manual.
/mnt/log/cmu_client.crt		
/mnt/home/cert/web/server.crt	Authenticates the validity of the peer web module to be connected.	

G Contact Information

If you have any questions about this product, please contact us.



<https://digitalpower.huawei.com>

Path: **About Us > Contact Us > Service Hotlines**

To ensure faster and better services, we kindly request your assistance in providing the following information:

- Model
- Serial number (SN)
- Software version
- Alarm ID or name
- Brief description of the fault symptom

 **NOTE**

EU Representative Information: Huawei Technologies Hungary Kft.
Add.: HU-1133 Budapest, Váci út 116-118., 1. Building, 6. floor.
Email: hungary.reception@huawei.com

H Digital Power Customer Service



<https://digitalpower.huawei.com/robotchat/>

Acronyms and Abbreviations

A

AI	analog input
APP	application

B

BMU	battery monitoring unit
------------	-------------------------

C

CAN	control area network
CMU	central monitoring unit
COM	cluster communication port

E

EPO	emergency power-off
ESC	smart rack controller
ESM	battery pack
ESR	battery rack

ESU energy storage unit

D

DC direct current

DO digital output

F

FE fast Ethernet

G

GE gigabit Ethernet

I

I/O input/output

L

LAN local area network

LED light-emitting diode

M

MBUS monitoring bus

N

NTC negative temperature
coefficient

P

PID	potential induced degradation
PSU	power supply unit
R	
RST	reset
S	
SACU	smart array controller
SFP	small form-factor pluggable
SIM	subscriber identity module
SMU	site monitoring unit
SN	serial number
SOC	state of charge
SOH	state of health
T	
TCU	temperature control unit
TOU	time-of-use price
U	
UPS	uninterruptible power system
USB	universal serial bus

W

WAN wide area network