



GENERATING SET GE 17000 HBT

The images are for reference



FEATURES

- Honda iGX engine with electronic speed control
- Electronic injection
- Automatic Starter (Auto- Choke)
- Auto-Idle function on request
- Electronic voltage regulation "AVR"
- Circuit breaker
- ELCB-GFI (Ground Fault Interruptor)
- Compliant with CE directives



air cooled



petrol



three-phase power



electric start

POWER RATINGS	
* Stand-By three-phase power (LTP)	16 kVA (12.8 kW) / 400 V / 23.1 A
* PRP three-phase power	14.5 kVA (11.6 kW) / 400 V / 20.5 A
* PRP single-phase power	7.5 kVA/kW / 230 V / 32.6A
Frequency	50 Hz
Cos φ	0.8

* Output powers according to ISO 8528-1

DEFINITION

Valid declared powers up to the followings environmental conditions: temperature 25°C, altitude 100 meters above sea level)

LTP power: stand-by power: Maximum available power for use with variable loads for a yearly number of hours limited at 500 h. No overload is admitted.

PRP power: continue power with variable loads. Maximum power for use with variable loads for a yearly illimited nubers of hours.

COP power: continuous power with constant load. Maximum power for use with constant loads for a yearly unlimited numbers of hours.

ENGINE 3000 RPM

4 STROKE OHV, NATURAL ASPIRATED	
Model	HONDA iGX 800
* Stand-By net power	16.8 kWm (22.8 hp)
* PRP net power	13.3 kWm (18 hp)
* COP net power	/
Cylinders / Displacement	2 a V / 779 cm ³ (0.779 lt.)
Bore / Stroke	83 / 72 (mm)
Compression ratio	9.1 : 1
BMEP (Brake Mean Effective Pressure : LTP - PRP)	/
Speed governor type	Electronic
FUEL CONSUMPTION	
110 % (Stand-by power)	6.9 lt./h
100 % to PRP	6.3 lt./h
75 % to PRP	4.7 lt./h
50 % to PRP	3.2 lt./h
COOLING SYSTEM	
Total system cap. - only engine	/
Fan air flow	/
LUBRICATION SYSTEM	
Total oil system capacity	/
Oil capacity in sump	2 lt.
Oil consumption at full load	/

EXHAUST SYSTEM	
Maximum exhaust gas flow	/
Max. exhaust gas temp.	/
Maximum back pressure	/
External diameter exhaust pipe	/
ELECTRICAL SYSTEM	
Starter motor power	/
Battery charging alternator cap.	20 A
Cold start	/
With cold start aid	/
AIR FILTER	
Combustion air flow	/
HEAT REJECTED AT FULL LOAD	
To exhaust system	/
To water and oil	/
Radiated to room	/
To charge cooler	/

ALTERNATOR

SYNCHRONOUS, THREE-PHASE, SELF-EXCITED, SELF-REGULATED	
Continuous power	15 kVA
Stand-by power	16.5 kVA
Three phase voltage	380 - 415 Vac
Frequency	50 Hz
Cos φ	0.8
Model A.V.R.	Digital
Voltage regulation acc.	± 1.5 %
Sustained short circuit current	3 In
Transient dip (100% load)	< 25 %
Recovery time	< 0.5 sec.
Efficiency at 100% load	/
Insulation	Class H
Connection - Terminals	Star (with N) - N°4
Electromagnetic compatibility (R.F.I. suppr.)	EN 61000-6-2 EN 61000-6-3
Waveform distortion - THD	< 5%
Telephone interference - THF	/

REACTANCES (15 kVA - 400 V)	
Direct axis synchronous - Xd	/
Direct axis transient - X'd	/
Subdirect axis transient - X''d	/
Quadrature axis synchronous - Xq	/
Quadr. axis subtransient - X''q	/
Negative sequence - X2	/
Zero sequence - X0	/
TIME CONSTANTS	
Transient - T'd	/
Subtransient - T''d	/
Open circuit - T'do	/
Armature - Ta	/
Short-circuit ratio Kcc	/
IP protection degree	IP 23
Cooling air flow	/
Coupling Bearing	Direct - N°1

GENERAL SPECIFICATIONS

Fuel tank capacity	18 lt.
Running time (75% to PRP)	3.8 h
Starter battery	12 Vdc -37Ah / 330A CCA(EN)

IP protection degree	IP 23
Acoustic power LwA (pressure LpA)	99 dB(A) (74 dB(A) @ 7m)
Performance class (ISO 8528)	G2

CONTROL PANEL

- Starter key
- Oil alert warning light (led)
- Hour meter
- Fuel tap
- Auto-Idle switch
- voltmeter
- Circuit breaker
- Differential-magneto-thermal switch for 230V 16A sockets
- Output sockets: 1x400V 32A 3P + N + T CEE IP67
1x230V 16A 2P+T CEE
1x230V 16A 2P+T SCHUKO
- Earth terminal (PE)



AUTOIDLE FUNCTION (OPTIONAL)

Usually petrol gensets are operating at high speed, 3000 rpm.

Experience has taught us that during their use, gensets very often operate with no load. This operation inevitably causes greater fuel consumption and therefore greater environmental pollution and greater noise in the working area.

With **AUTOIDLE** function all this is eliminated, as the engine runs at a low rpm, consequently lower fuel consumption and less noise, and only when current load is requested it automatically goes to the nominal rpm without delays and for any type of load.

WEIGHT - DIMENSIONS AND ACCESSORIES

GE 17000 HBM



DRY WEIGHT MACHINE:

- 160 Kg

Generating set pictured may include optional accessories.



DIMENSIONS DRAW (mm)

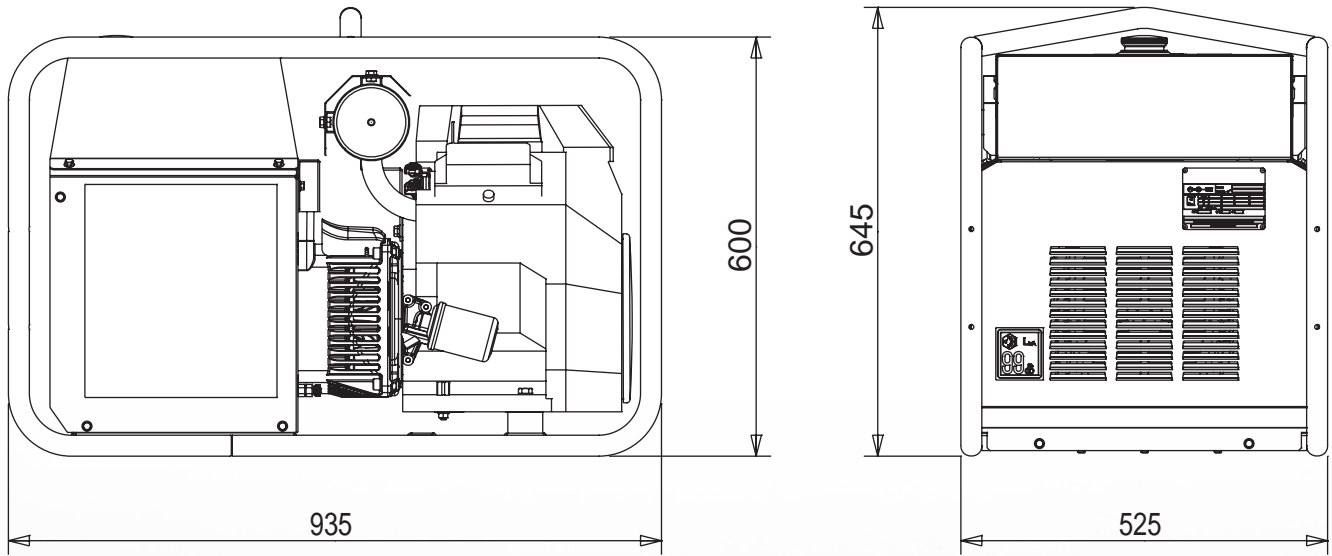

OPTIONS ON REQUEST

- Earthing
- Trolley CTM 10
- Tank cap with lock



VERSIONS ON REQUEST

- /



FACTORY INSTALLATION OPTIONS

- Auto Idle

GENERAL INFORMATION

COMPLIANCE GENERATING SETS WITH EC DIRECTIVES AND STANDARDS

- 2006/42 / EC (Machines Directive)
- 2014/35 / EU (Low Voltage Directive)
- 2014/30 / EU (EMC Directive)
- 2000/14 / EC (Directive Acoustic Emission for machines for use outdoors)
- ISO 8528 (Reciprocating internal combustion engine driven alternating current generating sets)



ISO 9001:2015 - Cert. 0192

WARRANTY

All devices are covered by the manufacturer's warranty.

The company reserves the right to change this specification without notice. For further information please contact the sales department.

© MOSA - Viale Europa, 59 - 20090 Cusago (Milano) - Italy - phone +39-0290352.1 - fax + 39-0290390466 E-mail: info@mosa.it Web site: www.mosa.it

